

***TM 55-1925-282-14&P**

TECHNICAL MANUAL

OPERATOR, UNIT, DIRECT SUPPORT AND
GENERAL SUPPORT MAINTENANCE
MANUAL INCLUDING
REPAIR PARTS AND SPECIAL TOOLS LIST
FOR
REVERSE OSMOSIS WATER PURIFICATION UNIT

INLAND AND COASTAL LARGE TUG (LT)
NSN 1925-01-509-7013 (EIC XAG)

*Supersedes TM 55-1925-217-24&P, 16 August 1991.

DISTRIBUTION STATEMENT A: Approved for public release; distribution is unlimited.

HEADQUARTERS, DEPARTMENT OF THE ARMY

NOVEMBER 2005

WARNING SUMMARY**FIRST AID**

Although the 128' Large Tug is normally assigned a medic, first aid is still an important skill for all crewmembers. The ability to promptly administer first aid to another crewmember could mean the difference between life and death for that crewmember. First aid procedures for soldiers are contained in FM 4-25.11.

WARNING SUMMARY CONTENT

This warning summary contains general safety warnings and hazardous materials warnings that must be understood and applied during operation and maintenance of this vessel and its equipment. Failure to observe these precautions could result in serious injury or death to personnel. Also included are explanations of safety and of hazardous materials used within the technical manual.

DRY CLEANING SOLVENT

Cleaning solvent is flammable and its vapor is potentially explosive. Do not use cleaning solvent in the vicinity of spark, open flame, or excessive heat. Do not use cleaning solvent in unventilated spaces. Failure to follow these precautions can result in death or serious injury.

ELECTRICAL

Take great care when working around energized electrical equipment. Contact between unprotected body parts and electrical conductors can cause serious injury or death. Do not wear jewelry or other conductive items while servicing energized electrical equipment. Failure to comply with these precautions can cause serious injury or death.

Replace or repair components only after the affected circuit has been secured, locked out, and tagged out. Performing replacement with the circuit energized may result in injury.

LOCKING HARDWARE

Never reuse locking hardware. Reuse of locking hardware such as lock washers, locking nuts, cotter pins, and lockwire can result in undetected loosening of fastening hardware causing catastrophic component failure resulting in death, injury, or damage to equipment. In accordance with TB 43-0218, ensure that all locking hardware is discarded upon removal and replaced with new.

PRESSURIZED LINES

Hydraulic hoses and lines may be under pressure. Relieve pressure by operating the appropriate control valve, if possible. Loosen fittings on hose lines slowly. Allow oil to run around threads of fitting, releasing pressure before disconnecting fitting. Releasing pressurized oil suddenly may cause severe personal injury.

EXPLANATION OF SAFETY WARNING ICONS



BIOLOGICAL - abstract symbol bug shows that a material may contain bacteria or viruses that present a danger to life or health.



CHEMICAL - drops of liquid on hand show that the material will cause burns or irritation to human skin or tissue.

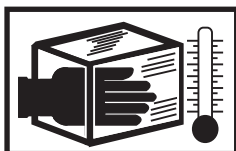

CRYOGENIC - hand in block of ice shows that the material is extremely cold and can injure human skin or tissue.



EAR PROTECTION - headphones over ears show that noise level will harm ears.



ELECTRICAL - electrical wire to arm with electricity symbol running through human body shows that shock hazard is present.



ELECTRICAL - electrical wire to hand with electricity symbol running through hand shows that shock hazard is present.

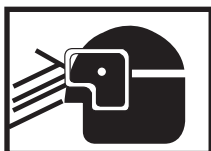

EYE PROTECTION - person with goggles shows that the material will injure the eyes.



EXPLOSION - rapidly expanding symbol shows that the material may explode if subjected to high temperatures, sources of ignition, or high pressure.



FALLING PARTS - arrow bouncing off human shoulder and head shows that falling parts present a danger to life or limb.

EXPLANATION OF SAFETY WARNING ICONS (continued)



FIRE - flame shows that a material may ignite and cause burns.



FLYING PARTICLES - arrows bouncing off face show that particles flying through the air will harm face.



FLYING PARTICLES - arrows bouncing off face with face shield show that particles flying through the air will harm face.



HEAVY OBJECT - human figure stooping over heavy object shows physical injury potential from improper lifting technique.



HEAVY PARTS - hand with heavy object on top shows that heavy parts can crush and harm.



HEAVY PARTS - foot with heavy object on top shows that heavy parts can crush and harm.



HEAVY PARTS - heavy object on human figure shows that heavy parts present a danger to life or limb.



HEAVY PARTS - heavy object pinning human figure against wall shows that heavy, moving parts present a danger to life or limb.



HELMET PROTECTION - arrow bouncing off head with helmet shows that falling parts present a danger.

EXPLANATION OF SAFETY WARNING ICONS (continued)



HOT AREA - hand over object radiating heat shows that part is hot and can burn.



LASER LIGHT - laser light hazard symbol indicates extreme danger for eyes from laser beams and reflections.



MOVING PARTS - human figure with an arm caught between gears shows that the moving parts of the equipment present a danger to life or limb.



MOVING PARTS - hand with fingers caught between gears shows that the moving parts of the equipment present a danger to life or limb.



MOVING PARTS - hand with fingers caught between rollers shows that the moving parts of the equipment present a danger to life or limb.



POISON - skull and crossbones show that a material is poisonous or is a danger to life.



RADIATION - three circular wedges show that the material emits radioactive energy and can injure human tissue.



SHARP OBJECT - pointed object in hand shows that a sharp object presents a danger to limb.



SHARP OBJECT - pointed object in hand shows that a sharp object presents a danger to limb.

EXPLANATION OF SAFETY WARNING ICONS (continued)



SHARP OBJECT - pointed object in foot shows that a sharp object presents a danger to limb.



SLICK FLOOR - wavy line on floor with legs prone shows that slick floor presents a danger for falling.



VAPOR - human figure in a cloud shows that material vapors present a danger to life or health.

CHANGE

NO. 1

HEADQUARTERS
DEPARTMENT OF THE ARMY
WASHINGTON, D.C., 30 JULY 2008

TECHNICAL MANUAL

OPERATOR, UNIT, DIRECT SUPPORT AND
GENERAL SUPPORT MAINTENANCE
MANUAL INCLUDING
REPAIR PARTS AND SPECIAL TOOLS LIST
FOR
REVERSE OSMOSIS WATER PURIFICATION UNIT

INLAND AND COASTAL LARGE TUG (LT)
NSN 1925-01-509-7013 (EIC XAG)

Distribution Statement A: Approved for public release; distribution is unlimited.

TM 55-1925-282-14&P, 30 November 2005, is changed as follows:

1. Remove and insert pages as indicated below. New or changed text is indicated by a vertical bar in the margin. An illustration change is indicated by a miniature pointing hand.

Remove pages

None

None

A/B blank

i through iv

0001 00-1 through 0001 00-4

0004 00-1 through 0004 00-12

0005 00-1 through 0005 00-20

0009 00-1 through 0009 00-10

0015 00-1 through 0015 00-4

0017 00-1 through 0017 00-4

0018 00-1 through 0018 00-12

0020 00-1 through 0020 00-4

0021 00-1 through 0021 00-4

0022 00-1 through 0022 00-6

0023 00-1 through 0023 00-2

0024 00-1 through 0024 00-20

0028 00-1 through 0028 00-2

0031 00-1 through 0031 00-2

0033 00-1 through 0033 00-30

DA Form 2028

Insert pages

Change Transmittal Sheet

Authentication Page

A/B blank

i through iv

0001 00-1 through 0001 00-4

0004 00-1 through 0004 00-12

0005 00-1 through 0005 00-20

0009 00-1 through 0009 00-10

0015 00-1 through 0015 00-4

0017 00-1 through 0017 00-4

0018 00-1 through 0018 00-12

0020 00-1 through 0020 00-4

0021 00-1 through 0021 00-4

0022 00-1 through 0022 00-6

0023 00-1 through 0023 00-2

0024 00-1 through 0024 00-20

0028 00-1 through 0028 00-4

0031 00-1 through 0031 00-2

0033 00-1 through 0033 00-30

DA Form 2028

2. Retain this sheet in front of the manual for reference purposes.

By Order of the Secretary of the Army:

GEORGE W. CASEY, JR.
General, United States Army
Chief of Staff

Official:



JOYCE E. MORROW
Administrative Assistant to the
Secretary of the Army
0819114

DISTRIBUTION: To be distributed in accordance with the initial distribution number (IDN) 255632, requirements for TM 55-1925-282-14&P.

INSERT LATEST CHANGED PAGES. DESTROY SUPERSEDED DATA.

LIST OF EFFECTIVE PAGES/WORK PACKAGES

NOTE: The portion of text affected by the changes is indicated by a vertical line in the outer margins of the page. Changes to illustrations are indicated by miniature pointing hands. Changes to wiring diagrams are indicated by shaded areas.

Dates of original issue and changed pages for this manual are:

Original 30 November 2005

Change 1 30 July 2008

TOTAL NUMBER OF PAGES FOR FRONT AND REAR MATTER IS 36 AND TOTAL NUMBER OF WORK PACKAGES IS 35, CONSISTING OF THE FOLLOWING:

Page/WP No.	* Change No.	Page/WP No.	* Change No.
Front Cover.....	0	Chp 6 title page	0
a-e	0	WP 0018 00 (12 pgs).....	1
f blank.....	0	WP 0019 00 (4 pgs).....	0
Change Transmittal Sheet.....	1	WP 0020 00 (4 pgs).....	1
Authentication Page	1	WP 0021 00 (4 pgs).....	1
A	1	WP 0022 00 (6 pgs).....	1
B blank.....	1	WP 0023 00 (2 pgs).....	1
i - iv	1	Chp 7 title page	0
Chp 1 title page	0	WP 0024 00 (20 pgs).....	1
WP 0001 00 (4 pgs).....	1	WP 0025 00 (4 pgs).....	0
WP 0002 00 (8 pgs).....	0	WP 0026 00 (4 pgs).....	0
WP 0003 00 (8 pgs).....	0	WP 0027 00 (4 pgs).....	0
Chp 2 title page	0	Chp 8 title page	0
WP 0004 00 (12 pgs).....	1	WP 0028 00 (4 pgs).....	1
WP 0005 00 (20 pgs).....	1	Chp 9 title page	0
WP 0006 00 (4 pgs).....	0	WP 0029 00 (2 pgs).....	0
Chp 3 title page	0	WP 0030 00 (4 pgs).....	0
WP 0007 00 (4 pgs).....	0	WP 0031 00 (2 pgs).....	1
WP 0008 00 (2 pgs).....	0	WP 0032 00 (6 pgs).....	0
WP 0009 00 (10 pgs).....	1	WP 0033 00 (30 pgs).....	1
Chp 4 title page	0	WP 0034 00 (14 pgs).....	0
WP 0010 00 (2 pgs).....	0	WP 0035 00 (2 pgs).....	0
WP 0011 00 (4 pgs).....	0	GLOSSARY-1	0
WP 0012 00 (4 pgs).....	0	GLOSSARY-2 blank	0
WP 0013 00 (2 pgs).....	0	Index-1 - Index-7	0
Chp 5 title page	0	Index-8 blank.....	0
WP 0014 00 (10 pgs).....	0	Electronic DA Form 2028.....	0
WP 0015 00 (4 pgs).....	1	DA 2028.....	1
WP 0016 00 (4 pgs).....	0	Authentication Page	0
WP 0017 00 (4 pgs).....	1	Rear Cover	0

* Zero in this column indicates an original page.

HEADQUARTERS,
DEPARTMENT OF THE ARMY
WASHINGTON, D.C., 30 NOVEMBER 2005

TECHNICAL MANUAL

OPERATOR, UNIT, DIRECT SUPPORT, AND GENERAL SUPPORT MAINTENANCE MANUAL
INCLUDING REPAIR PARTS AND SPECIAL TOOLS LIST
FOR
REVERSE OSMOSIS WATER PURIFICATION UNIT

INLAND AND COASTAL LARGE TUG (LT)
NSN 1925-01-509-7013 (EIC XAG)

REPORTING ERRORS AND RECOMMENDING IMPROVEMENTS

You can help improve this publication. If you find any errors, or if you would like to recommend any improvements to the procedures in this publication, please let us know. The preferred method is to submit your DA Form 2028 (Recommended Changes to Publications and Blank Forms) through the Internet, on the Army Electronic Product Support (AEPS) website. The Internet address is <https://aeprs.ria.army.mil>. The DA Form 2028 is located under the Public Applications section in the AEPS Public Home Page. Fill out the form and click on SUBMIT. Using this form on the AEPS will enable us to respond quicker to your comments and better manage the DA Form 2028 program. You may also mail, e-mail, or fax your comments or DA Form 2028 directly to the U.S. Army TACOM Life Cycle Management Command. The postal mail address is U.S. Army TACOM Life Cycle Management Command, ATTN: AMSTA-LC-LMPP / TECH PUBS, 1 Rock Island Arsenal, Rock Island, IL 61299-7630. The e-mail address is tacomlcmc.daform2028@us.army.mil. The fax number is DSN 793-0726 or Commercial (309) 782-0726.

DISTRIBUTION STATEMENT A: Approved for public release, distribution is unlimited.

TABLE OF CONTENTS

WP Sequence No.

WARNING SUMMARY

HOW TO USE THIS MANUAL

CHAPTER 1 - GENERAL INFORMATION, EQUIPMENT DESCRIPTION, AND THEORY
OF OPERATION

General Information	0001 00
Equipment Description and Data	0002 00
Theory of Operation	0003 00

CHAPTER 2 - OPERATOR INSTRUCTIONS

Description and Use of Operator Controls and Indicators	0004 00
Operation Under Usual Conditions	0005 00
Operation Under Unusual Conditions	0006 00

*Supersedes TM 55-1925-217-14&P, 16 August 1991

TABLE OF CONTENTS (continued)

WP Sequence No.

CHAPTER 3 -TROUBLESHOOTING PROCEDURES	
Troubleshooting Index	0007 00
Operator Troubleshooting Procedures	0008 00
Unit Troubleshooting Procedures	0009 00
CHAPTER 4 - MAINTENANCE INSTRUCTIONS	
Service Upon Receipt and Preparation for Storage	0010 00
PMCS Introduction	0011 00
Operator Preventive Maintenance Checks and Services (PMCS) Including Lubrication	0012 00
Unit Preventive Maintenance Checks and Services (PMCS) Including Lubrication ..	0013 00
CHAPTER 5 - OPERATOR MAINTENANCE INSTRUCTIONS	
Reverse Osmosis Water Purification Unit, Service	0014 00
Media Filter Subassembly, Service	0015 00
Prefiltration Subassembly, Service	0016 00
High Pressure Pump, Service	0017 00
CHAPTER 6 - UNIT MAINTENANCE INSTRUCTIONS	
Reverse Osmosis Water Purification Unit, Repair	0018 00
Fresh Water Flush Pump, Replace	0019 00
Media Filter Subassembly, Repair	0020 00
High Pressure Pump, Replace	0021 00
Membrane and Vessel Subassembly; Replace, Repair	0022 00
Charcoal Filter, Service	0023 00
CHAPTER 7 - DIRECT SUPPORT MAINTENANCE INSTRUCTIONS	
Reverse Osmosis Water Purification Unit, Repair	0024 00
Prefiltration Subassembly, Replace	0025 00
High Pressure Pump, Repair	0026 00
Charcoal Filter, Replace	0027 00
CHAPTER 8 - GENERAL SUPPORT MAINTENANCE INSTRUCTIONS	
Reverse Osmosis Water Purification Unit, Repair	0028 00
CHAPTER 9 - SUPPPORTING INFORMATION	
References	0029 00
Maintenance Allocation Chart (MAC) Introduction	0030 00
Maintenance Allocation Chart	0031 00
Repair Parts and Special Tools List Introduction	0032 00
Repair Parts and Special Tools List	0033 00
Components of End Item (COEI) and Basic Issue Items (BII) Lists	0034 00
Expendable and Durable Items List	0035 00
GLOSSARY	
INDEX	

HOW TO USE THIS MANUAL

USING THIS MANUAL

When using this manual, read and understand the entire maintenance action before performing the task. Also, read and understand all warnings, cautions, and notes as well as general safety precautions that apply to the task to be performed. The warning summary will inform personnel of hazards associated with the equipment to be worked on. However, the summary is not all inclusive and personnel should be aware at all times of hazardous conditions that may arise.

ACCESSING INFORMATION

Information is accessed by referring to the table of contents, located in the front of this manual, or by looking in the alphabetical index, located in the back of this manual.

To locate information using the table of contents, first scan the chapter titles to determine the general area in which your information will be contained. After locating the proper chapter, look beneath the chapter title to find the desired informational or procedural work package title. To the right of the work package title is a work package sequence number. This work package sequence number will direct you to the proper work package. Work packages are arranged in numerical order in this manual.

To locate information using the alphabetical index, look down the subject column on the left side of the page until you find the desired subject. To the right of the subject is the work package sequence number and page number. Go to the indicated work package and indicated page number to find the desired information.

INITIAL SETUP

Initial setup requirements are located directly above many of the procedures in this manual. The information is given to ensure all materials, expendables, tools and any other equipment necessary are readily available for use. The initial setup will be accomplished prior to starting the actual steps of each maintenance procedure. There are five basic headings listed under the initial setup:

Tools and Special Tools: This section lists all tools (standard or special) required to perform the task. Tools are identified with an item number and work package number from table 2 of the Maintenance Allocation Chart (MAC).

Materials/Parts: This section lists all of the materials and parts required to perform the task. If the material or part is needed each time the work package is used, then it is listed here. If the part is optional, replaced on a conditional basis, or is only needed for certain specific procedures within the work package it is not listed.

Personnel Required: This section lists all personnel necessary to perform the task. When a specific MOS or other personnel qualification is required, this MOS or additional requirement is also indicated.

References: This section lists any other publications necessary to complete the task. When there are no references listed, all steps necessary to complete the task are contained within this manual. A listing of reference materials is contained in the Supporting Information chapter at the rear of this manual.

Equipment Condition: This section notes the conditions that must exist before starting the task. The equipment condition will also include any prerequisite maintenance tasks to be performed with reference to the work package number or to the TM number that contains the required maintenance task.

ILLUSTRATIONS

Various visual methods are used to locate and repair components. Locator illustrations in Controls and Indicator tables, Preventive Maintenance Checks and Services (PMCS) tables, exploded views, and cut-away diagrams make the information in the manual easier to understand and follow.

LOCATING MAJOR COMPONENTS

This work package gives a brief description of the major components, and provides illustrations showing the location of the components. Knowing the major components of the system is the first step to understanding system operation and maintenance.

THEORY OF OPERATION

This work package contains the theory of operation for the system. Theory of operation is provided to familiarize the user system operating principles. Once the operating principles are understood, the user is better equipped to operate, troubleshoot, and maintain the system.

DESCRIPTION AND USE OF OPERATOR CONTROLS AND INDICATORS

This work package describes all of the operator controls and indicators contained in the system. Use of the operator controls and indicators is also described. Turn to the figure that shows the desired control or indicator. Note the key number corresponding to the control or indicator. Refer to the table below the illustration and find the desired key number in the column on the far left hand side. The center column contains the name of the control or indicator and the right hand column briefly describes the control or indicator's function.

OPERATOR INSTRUCTIONS

Work packages are included in this manual to describe operation under usual conditions as well as operation under unusual conditions. Prior to performing any operating procedure, perform the initial setup by obtaining the expendables, tools, materials and other items listed prior to starting the task. Always perform the listed steps in the listed order.

TROUBLESHOOTING PROCEDURES

A troubleshooting index work package is contained in this manual to permit easy location of troubleshooting procedures. Full directions for using the troubleshooting index and the accompanying troubleshooting procedures are contained in the troubleshooting index work packages. The troubleshooting procedure work package(s) immediately follow the troubleshooting index.

MAINTENANCE PROCEDURES

To locate a maintenance procedure, consult the table of contents or the alphabetical index. Each level of maintenance (operator, unit, direct support, and general support) has a chapter dedicated to maintenance procedures for the appropriate level of maintenance. Each maintenance work package contains complete maintenance procedures, starting with initial setup and continuing through follow on service as appropriate. Always ensure that all of the initial setup is complete before beginning a maintenance procedure and always ensure that all warnings, cautions, and notes are heeded.

MAINTENANCE ALLOCATION CHART

The MAC lists all of the authorized maintenance for the system and assigns that maintenance to the appropriate maintenance level (operator, unit, direct support, general support). Use of the MAC is explained fully in the Maintenance Allocation Chart Introduction work package.

REPAIR PARTS AND SPECIAL TOOLS LIST (RPSTL)

The RPSTL lists all of the repair parts authorized for the system. Illustrations are provided to assist in locating the desired repair parts. Full instructions for use of the RPSTL are contained in the Repair Parts and Special Tools List Introduction work package. Always follow the directions contained in this work package when using the RPSTL.

ALPHABETICAL INDEX

The Alphabetical Index, located in the back of this manual, contains an alphabetical list of all sections of this manual. For example, Location and Description of Major Components is found in section L. The work package sequence number is found on the right side of the title where the Location and Description of Major Components is located. Turn to the work package indicated to find the description and location of each component.

Chapter 1

General Information, Equipment Description, and Theory of Operation for Reverse Osmosis Water Purification Unit Inland and Coastal Large Tug (LT)

**OPERATOR, UNIT, DIRECT SUPPORT, AND GENERAL SUPPORT MAINTENANCE
REVERSE OSMOSIS WATER PURIFICATION UNIT FOR
INLAND AND COASTAL LARGE TUG (LT)
GENERAL INFORMATION**

GENERAL INFORMATION

SCOPE

The information in this manual applies to all Inland and Coastal Large Tugs (LT) with the Reverse Osmosis Water Purification Unit (ROWPU) installation. This manual contains operator instructions and maintenance procedures for the ROWPU system.

MAINTENANCE FORMS, RECORDS, AND REPORTS

Department of the Army forms and procedures used for equipment maintenance will be those prescribed by DA PAM 738-750, Functional Users Manual for The Army Maintenance Management System (TAMMS) and AR 700-138, Army Logistics Readiness and Sustainability.

REPORTING EQUIPMENT IMPROVEMENT RECOMMENDATIONS (EIR)

You can help improve this publication. If you find any mistakes or if you know of a way to improve the procedures, please let us know. Submit your DA Form 2028 (Recommended Changes to Equipment Technical Publications) through the Internet on the Army Electronic Product Support (AEPS) Website. The Internet address is <https://aeps.ria.army.mil>. The DA Form 2028 is located under the Public Applications section on the AEPS public home page. Fill out the form and click on SUBMIT. Using this form on the AEPS site will enable us to respond to your comments quicker and to manage the DA Form 2028 program better. You may also mail, fax or e-mail your letter or DA Form 2028 directly to: AMSTA-LC-LMPP / TECH PUBS, TACOM-RI, 1 Rock Island Arsenal, Rock Island, IL 61299-7630. The e-mail address is ROCK-TACOM-TECH-PUBS@conus.army.mil. The fax number is DSN 793-0726 or Commercial (309) 782-0726.

CORROSION PREVENTION AND CONTROL (CPC)

Corrosion Prevention and Control (CPC) of Army materiel is a continuing concern. It is important that any corrosion problems with this item be reported so that the problem can be corrected and improvements can be made to prevent the problem in future items.

Corrosion specifically occurs with metals. It is an electrochemical process that causes the degradation of metals. It is commonly caused by exposure to moisture, acids, bases, or salts. An example is the rusting of iron. Corrosion damage in metals can be seen, depending on the metal, as tarnishing, pitting, fogging, surface residue, and/or cracking.

Plastics, composites, and rubbers can also degrade. Degradation is caused by thermal (heat), oxidation (oxygen), solvation (solvents), or photolytic (light, typically UV) processes. The most common exposures are excessive heat or light. Damage from these processes will appear as cracking, softening, swelling, and/or breaking.

If a corrosion problem is identified, it can be reported using SF 368 (Product Quality Deficiency Report). Use of key words such as "corrosion," "rust," "deterioration," or "cracking" will ensure that the information is identified as a CPC problem. The form should be submitted to the address specified in DA PAM 738-750, Functional Users Manual for The Army Maintenance Management Systems (TAMMS).

OZONE DEPLETING SUBSTANCES

There are no Ozone Depleting Substances (ODS) contained in the ROWPU system.

DESTRUCTION OF ARMY MATERIEL TO PREVENT ENEMY USE

For procedures to destroy this equipment to prevent its use by the enemy, refer to TM 750-244-6, Procedures for Destruction of Tank - Automotive Equipment to Prevent Enemy Use.

PREPARATION FOR STORAGE OR SHIPMENT

Detailed procedures for preparing the reverse osmosis water purification unit for storage or shipment are contained in TB 740-97-4, Preservation of Vessels for Storage and TM 38-470, Storage and Maintenance of Army Prepositioned Stock Materiel. These systems must be prepared for storage or shipment in accordance with that publication. Additional instructions can be found in WP 0010 00.

WARRANTY INFORMATION

Unit maintenance maintains records of the warranty status of equipment on the ROWPU system. The warranty starts on the date found in block 23 of DA Form 2408-9 (Equipment Control Record). Report all defects to your supervisor, who will take appropriate action.

LIST OF ABBREVIATIONS/ACRONYMS

Abbreviation/Acronym	Name
°C	Degrees Centigrade
°F	Degrees Fahrenheit
A	Amp(s)
AAL	Additional Authorization List
BII	Basic Issue Items
cm	Centimeter(s)
COEI	Components of End Item
COTS	Commercial Off the Shelf
CPC	Corrosion Prevention and Control
EIR	Equipment Improvement Recommendations
ft	Foot(feet)
ft ²	Square foot(feet)
ft ³ /min	Cubic feet per minute
FM	Flow Meter
FWF	Fresh Water Flush
GS	General Service
in	Inch(es)
in ³	Cubic Inch(es)
L	Liter(s)
L/min	Liters per minute
lb	Pound(s)
lb-ft	Pounds Feet (torque)
LT	Large Tug
m	Meter(s)
m ²	Square meter(s)
MAC	Maintenance Allocation Chart

LIST OF ABBREVIATIONS/ACRONYMS (continued)

Abbreviation/Acronym	Name
Nm	Newton Meter
ODS	Ozone Depleting Substance(s)
PG	Pressure Gauge
PMCS	Preventive Maintenance Checks and Services
PPM	Parts Per Million
PSI	Pounds per Square Inch
RO	Reverse Osmosis
ROWPU	Reverse Osmosis Water Purification Unit
REV	Reverse
TAMMS	The Army Maintenance Management System
TMDE	Test, Measurement, and Diagnostic Equipment
V	Valve
Vac	Volts, Alternating Current
Vdc	Volts, Direct Current
UV	Ultraviolet
WTR MTR	Water Meter

QUALITY OF MATERIAL

Material used for replacement, repair, or modification must meet the requirements of this manual. If quality of material requirements are not stated in this manual, the material must meet the requirements of the drawings, standards, specifications, or approved engineering change proposals applicable to the subject equipment.

END OF WORK PACKAGE

**OPERATOR, UNIT, DIRECT SUPPORT, AND GENERAL SUPPORT MAINTENANCE
REVERSE OSMOSIS WATER PURIFICATION UNIT FOR
INLAND AND COASTAL LARGE TUG (LT)
EQUIPMENT DESCRIPTION AND DATA**

EQUIPMENT CHARACTERISTICS, CAPABILITIES, AND FEATURES

The Reverse Osmosis Water Purification Unit (ROWPU) System is comprised of two separate units that use common components such as inlet and outlet piping, media filter, fresh water flush pump, miscellaneous gauges, valves, piping, and 24 Vdc power source to produce fresh water. Additionally, each ROWPU is outfitted with individual canister filters, high pressure pumps, Reverse Osmosis (RO) membranes, flow control panels, system controllers, charcoal filters, and separate 440 Vac power sources. The technical characteristics of these components are detailed in the Equipment Data paragraph in this work package. Theory of operation is outlined in WP 0003 00.

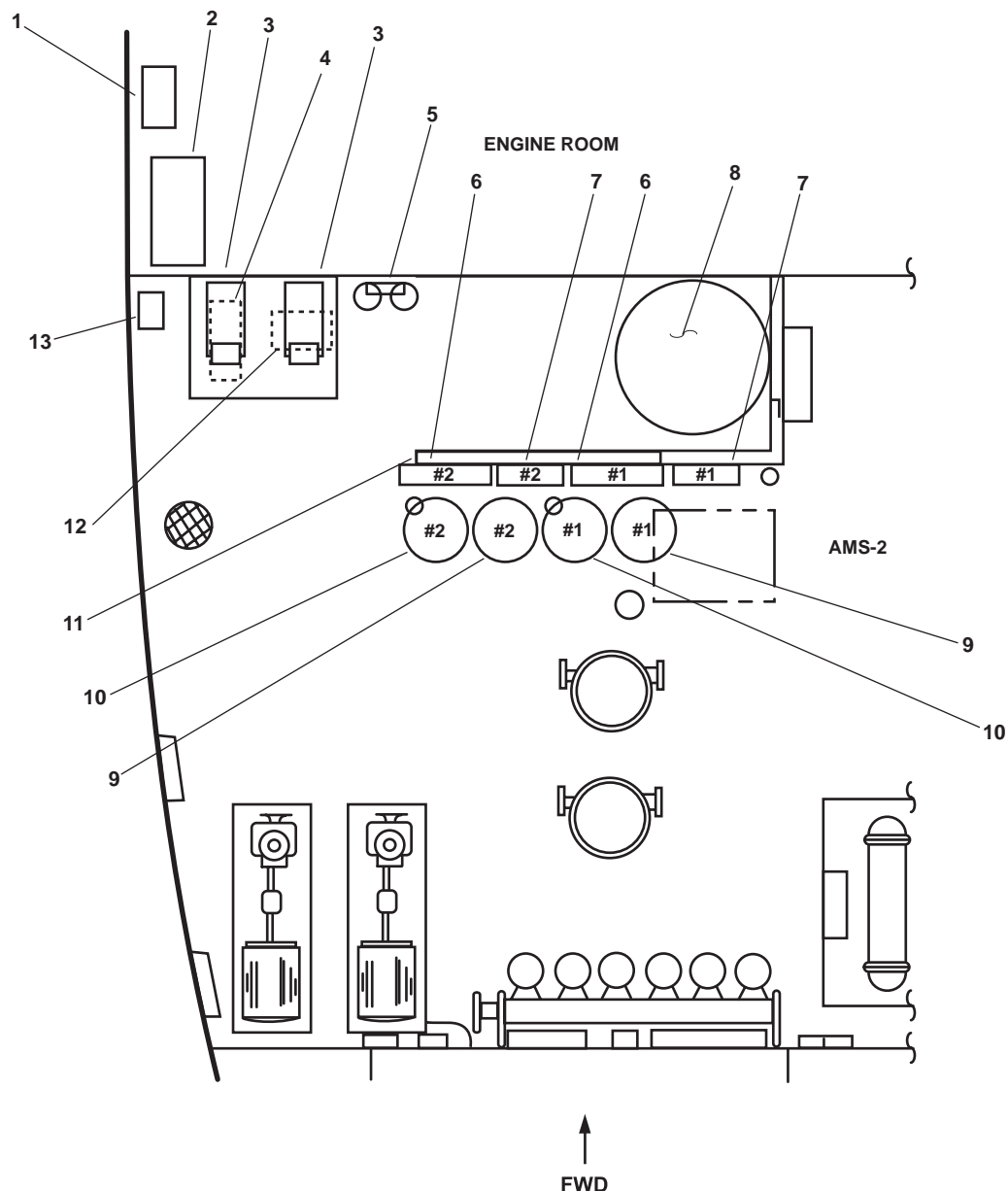

Figure 1. Major System Components

LOCATION AND DESCRIPTION OF MAJOR COMPONENTS

1. ROWPU System 24 Vdc Battery Charger/Power Supply (figure 1, item 1). The battery charger/power supply provides 24 Vdc to recharge the battery bank, and it provides 24 Vdc during normal ROWPU operation.
2. 24 Vdc Battery Bank (figure 1, item 2). Stand-alone battery bank that provides power to the ROWPU system during layup periods. The battery bank is capable of providing power to maintain fresh water flush cycles for up to 90 days without being recharged.
3. High Pressure Pumps (figure 1, item 3). The high pressure pumps provide filtered high pressure raw water to the RO membrane elements.
4. Fresh Water Flush Pump (figure 1, item 4). The fresh water flush pump (located beneath the high pressure pumps) provides the fresh water needed for flushing the ROWPU system during maintenance and layup periods.
5. Charcoal Filters (figure 1, item 5). The charcoal filters remove sediment and odors from the fresh water used during flushing cycles. The charcoal filters also block bromine and chlorine from passing into the reverse osmosis membranes.
6. Flow Control Panels (figure 1, item 6). The flow control panels provide the operator with the indicators needed to monitor the quantity and quality of product water, and the means to control overall system pressure.
7. System Controllers (figure 1, item 7). The system controllers monitor and control all processes accomplished by the ROWPU system.
8. Media Filter (figure 1, item 8). The media filter removes suspended particles 30-micron and larger from the raw water. This provides protection and longer life to the 20-micron filter element.
9. 20-Micron Filters (figure 1, item 9). The 20-micron filters remove suspended particles 20-micron and larger from the raw water. This provides protection and longer life to the 5-micron filter element.
10. 5-Micron Filters (figure 1, item 10). The 5-micron filters remove suspended particles 5-micron and larger from the raw water. This provides protection and longer life to the high pressure pumps and RO membranes.
11. Reverse Osmosis (RO) Membrane Elements (figure 1, item 11). The RO membranes convert high pressure raw water into potable drinking water.
12. ROWPU System 24 Vdc Control Panel (figure 1, item 12). The 24 Vdc Control Panel (located beneath the high pressure pumps) provides the operator with a means of locally monitoring and securing 24 Vdc to the ROWPU. The battery will still maintain a charge even if these breakers are OFF. This switch must remain ON in order for the ROWPU system controllers to monitor the system and conduct fresh water flushes during layup periods.
13. ROWPU 24 Vdc Fuse Box (figure 1, item 13). The fuse box provides 24 Vdc circuit protection to the ROWPU system in the event of a casualty or damage to the ROWPU system 24 Vdc battery charger/power supply or the 24 Vdc battery bank.

DIFFERENCES BETWEEN MODELS

At the time of issue for this manual, only hull number LT-803 had been outfitted with the ROWPU system upgrade. Therefore, no differences between models currently exist. As other vessels are upgraded, this manual will be revised to reflect those installations, and the differences between models will be identified at that time.

EQUIPMENT DATA

ROWPU SYSTEM 24 VDC BATTERY CHARGER/POWER SUPPLY

The battery charger/power supply provides 24 Vdc to recharge the battery, and it provides 24 Vdc during normal ROWPU operation.

The technical characteristics of the battery charger/power supply is contained in table 1.

Table 1. ROWPU System 24 Vdc Battery Charger/Power Supply Technical Characteristics

Item	Data
Manufacturer	La Marche
Model	A41-40-24V-A1
Input Voltage	120 Vac, 1 phase, 50/60 Hz
Input Amps	20 A
Output Voltage	24 Vdc
Output Amps	40 A

HIGH PRESSURE PUMPS

The high pressure pumps provide filtered high pressure raw water to the RO membrane elements. The maximum pressure the ROWPU can safely operate is 950 PSI (65.5 bar). To prevent exceeding the safety limit, the high pressure switch automatically shuts the ROWPU off at 925 PSI (63.8 bar).

The technical characteristics of the high pressure pumps are contained in table 2.

Table 2. High Pressure Pumps Technical Characteristics

Item	Data
Manufacturer	GP Companies, Inc.
Model	WM 42156
Type	Positive Displacement Ceramic Plunger
Rated Capacity	4.2 gallons (15.9 liters) per minute
Maximum Pressure	1500 PSI (103.4 bar)
Continuous Working Pressure	900 PSI (62 bar)
Voltage	440 Vac, 3 phase, 60 Hz
Startup Amps	35 A
Running Amps	4.1 A

FRESH WATER FLUSH PUMP

The fresh water flush pump provides the fresh water needed for flushing the ROWPU system during maintenance and layup periods.

The technical characteristics of the fresh water flush pump are contained in table 3.

Table 3. Fresh Water Flush Pump Technical Characteristics

Item	Data
Manufacturer	Jabsco
Model	PAR-MAX4
Type	Centrifugal
Rated Capacity	10 gallons (37.9 liters) per minute
Maximum Pressure	50 PSI (3.4 bar)
Continuous Working Pressure	40 PSI (2.8 bar)
Voltage	24 Vdc
Amps	10 A

CHARCOAL FILTERS

The charcoal filters remove sediment and odors from the fresh water used during flushing cycles. The charcoal filters also block bromine and chlorine from passing into the reverse osmosis membranes. The charcoal filters are secured when the ROWPU is making product water.

The technical characteristics of the charcoal filters are contained in table 4.

Table 4. Charcoal Filters Technical Characteristics

Item	Data
Manufacturer	Sea Recovery Corporation
Model	0713020606
Type	10 Micron Carbon Briquette
Maximum Pressure	50 PSI (3.4 bar)
Continuous Working Pressure	40 PSI (2.8 bar)

FLOW CONTROL PANELS

The flow control panels provide the operator with the indicators needed to monitor the quantity and quality of product water. They also provide the primary control needed to vary overall system pressure. It is the central connection point for all mechanical lines in the ROWPU system.

The technical characteristics of the flow control panels are contained in table 5.

Table 5. Flow Control Panels Technical Characteristics

Item	Data
Manufacturer	Water & Power, Inc. (The Watermaker Store)
Model	WAT-05MH3-776221350
Type	Mil-Type Flow Control Panel

SYSTEM CONTROLLERS

The system controllers monitor, start, and stop all processes required by the ROWPU system. It is the central electrical connection point in the system. It also serves as the safeguard to ensure that only potable product water is allowed to pass into the product water storage tanks. The controller monitors the salt content of the product water by means of the salinity probe, and it signals the 3-way diverter valve when potable water is being produced. The three-way diverter valve and pump motors are all directly connected to, and controlled by, the System Controller. The system controllers also monitor and sense signals from the low and high pressure shutdown switches and halt system operation when an alarm condition exists. Finally, the controllers have an hour meter that displays the total use hours of the system. This assists in following regular scheduled maintenance by keeping track of the 500 hour increments.

The technical characteristics of the system controllers are contained in table 6.

Table 6. System Controllers Technical Characteristics

Item	Data
Manufacturer	Sea Recovery Corporation
Model	B595800007
Voltages	440 Vac, 60 Hz, 3 phase, 24 Vdc

MEDIA FILTER

The media filter contains a graduated media filter bed made of fine sand substrate. The sand traps suspended solids larger than 30 microns. This provides protection and longer life to the 20-micron filter element. The substrate sand in the media filter requires infrequent change due to the ability to backflush and rinse the media filter substrate. During backflushing, the media filter is completely isolated from the rest of the ROWPU, while raw water cleans and flushes debris overboard.

Backflushing alters the direction of raw water flow inside the media filter. This allows the substrate to be purged of the filtered contents if the media filter becomes clogged. The inlet pressure gauge is the first indication that raw water is available to the ROWPU. The raw water inlet pressure should normally be about 40 PSI (2.8 bar). Inlet pressure should never exceed 50 PSI (3.4 bar) or damage to the ROWPU could occur. After backflushing, the media filter is rinsed to change out the raw water. If necessary, the media filter can be bypassed. However, this will shorten the life of the 20-micron filter.

The media filter outlet pressure gauge provides an indication of raw water differential pressure across the media filter. A media filter outlet pressure gauge reading 20 PSI (1.4 bar) lower than the media filter inlet gauge indicates that the media filter is clogged. Backflushing the media filter regularly will prevent excessive differential pressure.

The technical characteristics of the media filter are contained in table 7.

Table 7. Media Filter Technical Characteristics

Item	Data
Manufacturer	Water & Power, Inc. (The Watermaker Store)
Model	B071080002
Type	Back Washable Sand Filter
Rated Capacity	16 gallons (60.6 liters) per minute
Maximum Pressure	50 PSI (3.4 bar)
Continuous Working Pressure	40 PSI (2.8 bar)

20-MICRON FILTER

The 20-micron filters remove suspended particles from the raw water 20-micron and larger in size. This provides protection and longer life to the 5-micron filter.

The technical characteristics of the 20-micron filters are contained in table 8.

Table 8. 20-Micron Filter Technical Characteristics

Item	Data
Manufacturer	Sea Recovery Corporation
Series	Aqua Whisper
Model	286432011
Type	Commercial Style Pre-Filter
Maximum Pressure	50 PSI (3.4 bar)
Continuous Working Pressure	40 PSI (2.8 bar)

5-MICRON FILTER

The 5-micron filters remove suspended particles from the raw water 5-micron and larger in size. This protects and provides longer service life to the high pressure pumps and RO membranes.

The technical characteristics of the 5-micron filters are contained in table 9.

Table 9. 5-Micron Filter Technical Characteristics

Item	Data
Manufacturer	Sea Recovery Corporation
Series	Aqua Whisper
Model	286432012
Type	Commercial Style Pre-Filter
Maximum Pressure	50 PSI (3.4 bar)
Continuous Working Pressure	40 PSI (2.8 bar)

REVERSE OSMOSIS MEMBRANE ELEMENTS

The RO membranes convert high pressure raw water into potable drinking water by means of spiral wound membranes. These membranes consist of one or more membrane envelopes that are formed by enclosing a product water carrying material between two large flat membrane sheets. The membrane envelope is sealed on three edges and is attached to a small diameter pipe to form a cylinder 4 inches in diameter and 48 inches in length. A polypropylene screen is used to form the raw water channel between the membrane envelopes. A special wrap is applied to the membrane element to help it maintain the cylindrical configuration when outside the tube. ROWPU-1 has two elements connected in series to double the capacity of ROWPU-2.

The technical characteristics of the RO membranes are contained in table 10.

Table 10. Reverse Osmosis Membrane Elements Technical Characteristics

Item	Data
Manufacturer	Sea Recovery Corporation
Series	Aqua Whisper
Model	523909140
Type	46 inch (1.17 meter) Long Pressure Vessel
Maximum Pressure	1000 PSI (68.9 bar)
Continuous Working Pressure	900 PSI (62 bar)
Maximum Fluid Temperature	122 °F (50 °C)
Minimum Fluid Temperature	33 °F (0.5 °C)

END OF WORK PACKAGE

**OPERATOR, UNIT, DIRECT SUPPORT, AND GENERAL SUPPORT MAINTENANCE
REVERSE OSMOSIS WATER PURIFICATION UNIT FOR
INLAND AND COASTAL LARGE TUG (LT)
THEORY OF OPERATION**

INTRODUCTION

The purpose of this work package is to introduce the reader to the Reverse Osmosis Water Purification Unit (ROWPU) used aboard the LT. This work package explains what osmosis is and how the process is manipulated mechanically to produce fresh water. The work package also explains how reverse osmosis water purification is accomplished onboard the LT.

PRINCIPLES OF REVERSE OSMOSIS

The specific process through which osmosis occurs is called ion exclusion. A concentration of ions at the membrane surface forms a barrier that allows pure water molecules to pass while excluding molecules of foreign materials.

OSMOSIS

Osmosis is the diffusion of two mixable solutions through a semi-permeable membrane in such a manner as to equalize their concentrations. Natural osmosis occurs when a substance of lesser salinity naturally diffuses through a membrane into a higher concentration salinity. Cellular functions in the human body function in this manner. The process is very energy efficient in that it requires very little heat or pressure. However, the warmer the liquids, the more efficient the process due to the activity of the molecules. It is a natural function for liquids of unequal density to try to equalize themselves with one another when they are in molecular contact. In natural osmosis, liquids that are less saline attempt to equalize pressure by becoming more saline. The membrane of a living cell (figure 1, item 1) passes lower density saline solution (figure 1, item 2) into higher density saline solutions (figure 1, item 3). This happens because the lower density solution (figure 2, item 1) inside the cell naturally moves to equilibrium with the higher density solution (figure 2, item 2) the cell is located in. The cell membrane (figure 2, item 3) allows liquid to pass, but it prevents particles (figure 2, item 4) from passing.

REVERSE OSMOSIS

Osmosis is an important process to life, but it does not produce water that is palatable to humans. In order to produce water, the osmosis process must be reversed. The same principles apply, but some form of energy is necessary to force osmosis reversal. Thus, the process called 'reverse osmosis' was engineered to overcome the natural phenomenon of osmosis. Reverse osmosis works by forcing water of a higher salinity content through some type of semi-permeable membrane in an effort to remove the impurities. Salt is one of the impurities that is removed during the reverse osmosis process, and this makes it possible to create potable drinking water from undrinkable water sources.

PRINCIPLES OF REVERSE OSMOSIS

Osmosis is defined as the spontaneous passage of a liquid from a diluted solution to a more concentrated solution across a semi-permeable membrane. This allows the passage of the solvent (water), but halts the dissolved solids (solutes). In naturally occurring osmosis, this transfer of water from one side of the membrane to the other will continue until the pressure is equalized on both sides of the membrane. When at equilibrium, the quantities of liquid passing in either direction is equal. The force created that causes osmosis to occur is called 'osmotic pressure'. In natural occurring functions, fluids will flow from the purer side to the saline side of the membrane until the osmotic pressures are equalized. If the osmotic pressure on the saline side of the membrane is higher, fluid is forced to flow through the membrane in reverse. This is how the solution containing the higher salt concentration flows into the solution with the lower salt concentration. This process is called Reverse Osmosis (RO).

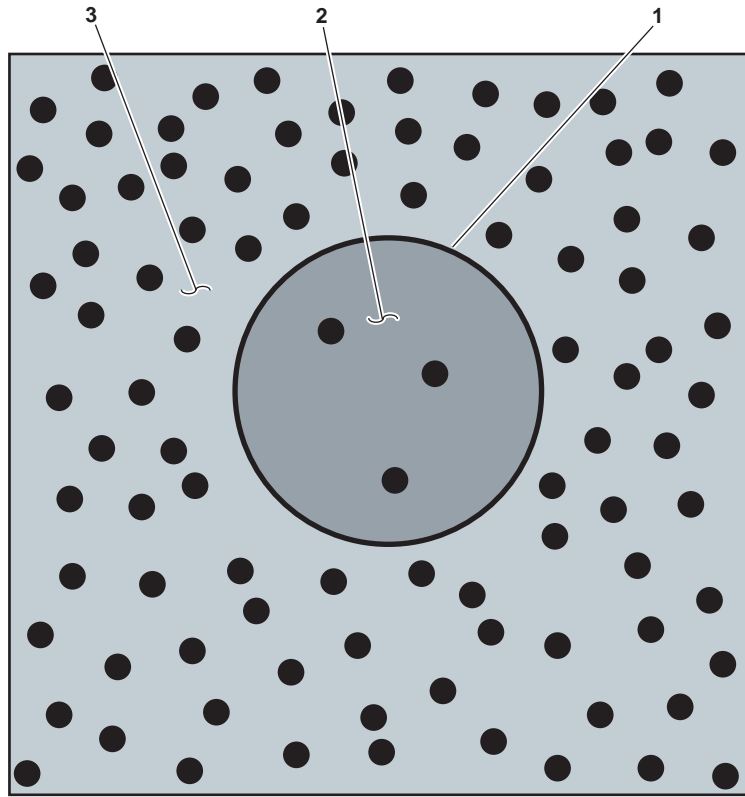

Figure 1. Living Cell Prior to Naturally Occurring Osmosis

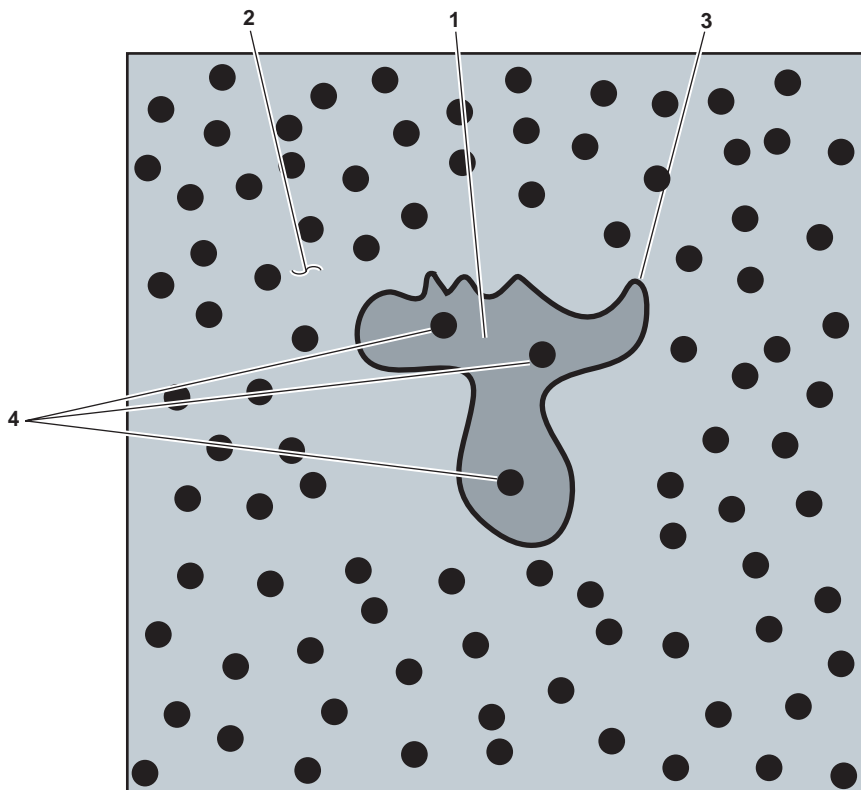

Figure 2. Living Cell After Naturally Occurring Osmosis

SPIRAL WOUND MEMBRANE

Reversing a natural occurring process requires solutions to many problems. The first problem is how to efficiently recreate the effect so that a sufficient quantity of fresh water can be produced. Natural osmosis occurs at the cellular level. This means that since there are billions of cells in the body using osmosis, there must be billions of reactions occurring at the same time. All these reactions occur in a relatively small space. We can't create billions of cells, but we can create one large one that does the same thing. So, the solution is to increase the surface area using one giant cell. The giant cell theory led to the development of the spiral wound membranes that are used in the ROWPU.

If each side of the membrane were unrolled and laid flat, they would cover an area of fifteen square acres. The membrane sheets are only two molecules thick, and they are rolled into spirals and placed into tubes that are about four feet long and three inches in diameter. Reverse osmosis requires the membranes to be very thin, and they are delicate and sensitive to damage when mishandled. The membranes are also very sensitive to clogging. In natural osmosis, the fluids do their job by going back and forth. When water is made for potable use, the fluid only flows one way. This causes clogs due to the build up of solids, so the solids must be removed.

The solids are washed away by allowing more water to flow past the saline side of the membranes than is allowed to pass through the membrane. The ratio for the ROWPU is five gallons of raw water used for every two gallons of fresh water produced. Mechanically, the membranes act as filters to keep the salt and other impurities from passing to the fresh water side. If the solids were not removed, the membranes would quickly clog. The raw water is also passed through various filters that remove impurities down to 5 microns in size. This results in greatly increasing the life of the membranes and a cost effective and low maintenance unit.

WATER TEMPERATURE EFFECT

Water flow through the membrane is significantly affected by the water temperature. The higher the water temperature, the more active the water molecules. The more active the water molecules, the easier it is to push them through the membranes. This means that at any given pressure, the flow rate will increase as water temperature increases. When the temperature is reduced, the flow rate for a given pressure is reduced. The operating pressure also has a direct effect on product water quantity. It takes less pump pressure to achieve the unit's rated capacity in warmer water. In order to reach the rated service life of the membranes, the system must be operated at the lowest pressure necessary to achieve the designed product water flow rate. In warm water, the system will easily make more water than rated capacity. However, exceeding rated capacity will shorten the service life of the membranes.

REVERSE OSMOSIS WATER PURIFICATION UNIT (ROWPU) OPERATING PRINCIPLES

The LT's General Service (GS) system provides raw water to the ROWPU. ROWPU 1 can make 1500 gallons (5678 liters) a day, and ROWPU 2 can make 800 gallons (3028 liters) a day. These values are easily achievable if the high pressure pumps do not exceed 900 PSI (62 bar) and if overall differential pressure never exceeds 25 PSI (1.7 bar). The raw water entering the system passes through three filtering cycles so that solids no larger than 5 microns will enter the membranes. After being filtered, the raw water is pressurized and directed to a semi-permeable membrane. The semi-permeable membrane permits the passage of water and rejects the other contaminants. After passing through the membrane, waste water is expelled via the general service system overboard discharge, and potable water is sent to the brominator for chemical treatment before being discharged to the potable water tanks.

COMPONENTS OF THE ROWPU

Table 1 outlines the major functional components of the ROWPU system. The item number corresponds to the callouts in figure 3. The components are outlined in a logical fashion that will allow the reader to understand the basic operating principles of the ROWPU. The ROWPU contains two units. ROWPU 1 (the starboard unit) is fitted with two reverse osmosis membranes, and ROWPU 2 (the port unit) has only one membrane.

Table 1. Major Functional Components of the ROWPU System (Refer to Figure 3)

Item No. (Refer to Figure 3)	Nomenclature	Description
1	ROWPU System General Service Pressure Reducing Valve	The pressure reducing valve ensures that overall general service system pressure is maintained at a maximum of 60 PSI (4.1 bar).
2	ROWPU System Raw Water Cutout Valve	The cutout valve allows the operator to secure raw water to the ROWPU system.
3	ROWPU System Raw Water Pressure Regulator	The pressure regulator maintains the raw water supply to the ROWPU system at a constant pressure of 40 PSI (2.8 bar).
4	ROWPU System Pressure Relief Valve	The pressure relief valve protects the ROWPU system by providing pressure relief when raw water pressure exceeds 50 PSI (3.4 bar).
5	ROWPU System Media Filter	The media filter uses sand as a substrate to remove larger particles that would cause clogging of the 20-micron pre-filter. The substrate in the media filter requires very infrequent change out due to the ability to back flush. During back flushing, the media filter is completely isolated from the rest of the ROWPU system, while raw water from the general service system cleans and flushes debris overboard. The media filter prolongs the service life of the 20-micron filter.
6	20-micron Filter	The 20-micron pre-filter removes all particulate in the raw water not removed by the media filter down to particles 20 microns in size. This filter serves to prolong the service life of the 5-micron pre-filter.
7	5-Micron Filter	The 5-micron pre-filter removes all particulate in the raw water not removed by the 20-micron pre-filter down to particles 5 microns in size. This filter serves to prolong the service life of the reverse osmosis membranes.
8	High Pressure Pumps	The high pressure pumps provide a source of low volume, high pressure raw water to the reverse osmosis membranes. The high pressure pumps are rated to deliver 4 gallons (15.1 liters) of filtered raw water per minute, at a maximum operating pressure of 900 lb/in ² (62 bar). The high pressure pumps provide the fluid energy necessary to cause the osmosis process to be reversed in the membranes.
9	Reverse Osmosis Membranes	The membranes convert filtered raw water into drinking water by allowing only water molecules to pass through its spiraled membrane. The high pressure/low volume pumps push raw water through the membranes to make fresh water, and they push the brine out of the membranes and overboard.

Table 1. Major Functional Components of the ROWPU System (Refer to Figure 3) (continued)

Item No. (Refer to Figure 3)	Nomenclature	Description
10	Solenoid Operated 3-Way Diverter Valve	The solenoid operated 3-way diverter valves are controlled by the system controllers (figure 3, item 14). The controllers sense the salinity of the product water output by the membranes. If the product water salinity is within tolerances, the product water is sent to the brominator and on to the potable water tanks. If product water salinity is too high, the product water is diverted and sent overboard as ROWPU system product brine.
11	ROWPU System Product Brine Discharge	Brine is the by-product of reverse osmosis. The brine is pumped overboard via the general service system overboard discharge. The ROWPU system is protected from the general service system by means of a check valve that acts as a backflow preventor.
12	Fresh Water Flush Pump	The fresh water flush pump is a low pressure pump that is used to clean and to prepare the ROWPU system for use. It is a 24 Vdc pump controlled by the system controller. The fresh water pump uses filtered potable water to purge raw water from the filtration system and from the raw water side of the reverse osmosis membranes. When the ROWPU is not in use, the system controllers automatically perform a fresh water flush once a week. The fresh water flush serves to prolong the life of the membranes, and it eliminates the need to 'pickle' the membranes for layup.
13	Charcoal Filters	The charcoal filters remove sediment and foul odors from the potable water used during flushing cycles. The charcoal filters also block bromine and chlorine from passing into the reverse osmosis membranes. The charcoal filters are secured when the ROWPU is making product water, and are protected by cutoff valves and a backflow preventor.
14	System Controllers	The system controllers are microprocessor-based water purification monitors and controllers. They control power to the pumps, monitor the quality of the output potable water, and monitor system operating pressures. The system controller turns the high pressure and fresh water flush pumps ON and OFF as required by system demands and operating conditions. The system controller also measures the salinity of the product water and controls the position of the solenoid operated 3-way diverter valve accordingly. Finally, the system controllers monitor system operating pressures. Any system pressure out of tolerance will cause the controller to stop the process and indicate an alarm. Power input to the system controllers is 450 Vac and 24 Vdc.

Table 1. Major Functional Components of the ROWPU System (Refer to Figure 3) (continued)

Item No. (Refer to Figure 3)	Nomenclature	Description
15	ROWPU System 24 Vdc Control Panel	The breaker and meter provide the operator with a means of monitoring and securing 24 Vdc to the ROWPU locally. The battery will still maintain a charge even if this switch is OFF. This switch must be ON in order for the ROWPU to monitor the system and conduct fresh water flushes.
16	ROWPU 24 Vdc Fuse Box	The fuse box provides 24 Vdc circuit protection in the event of a battery bank or battery charger casualty.
17	ROWPU System 24 Vdc Battery Bank	The battery bank provides power to the controllers and to the fresh water flushing pump during layup periods. A properly maintained and charged battery will provide adequate power to maintain the weekly fresh water flushing cycle for up to 90 days without recharging.
18	ROWPU System 24 Vdc Battery Charger/Power Supply	The battery charger/power supply provides 24 Vdc to recharge the battery, and it provides 24 Vdc during normal ROWPU operation.

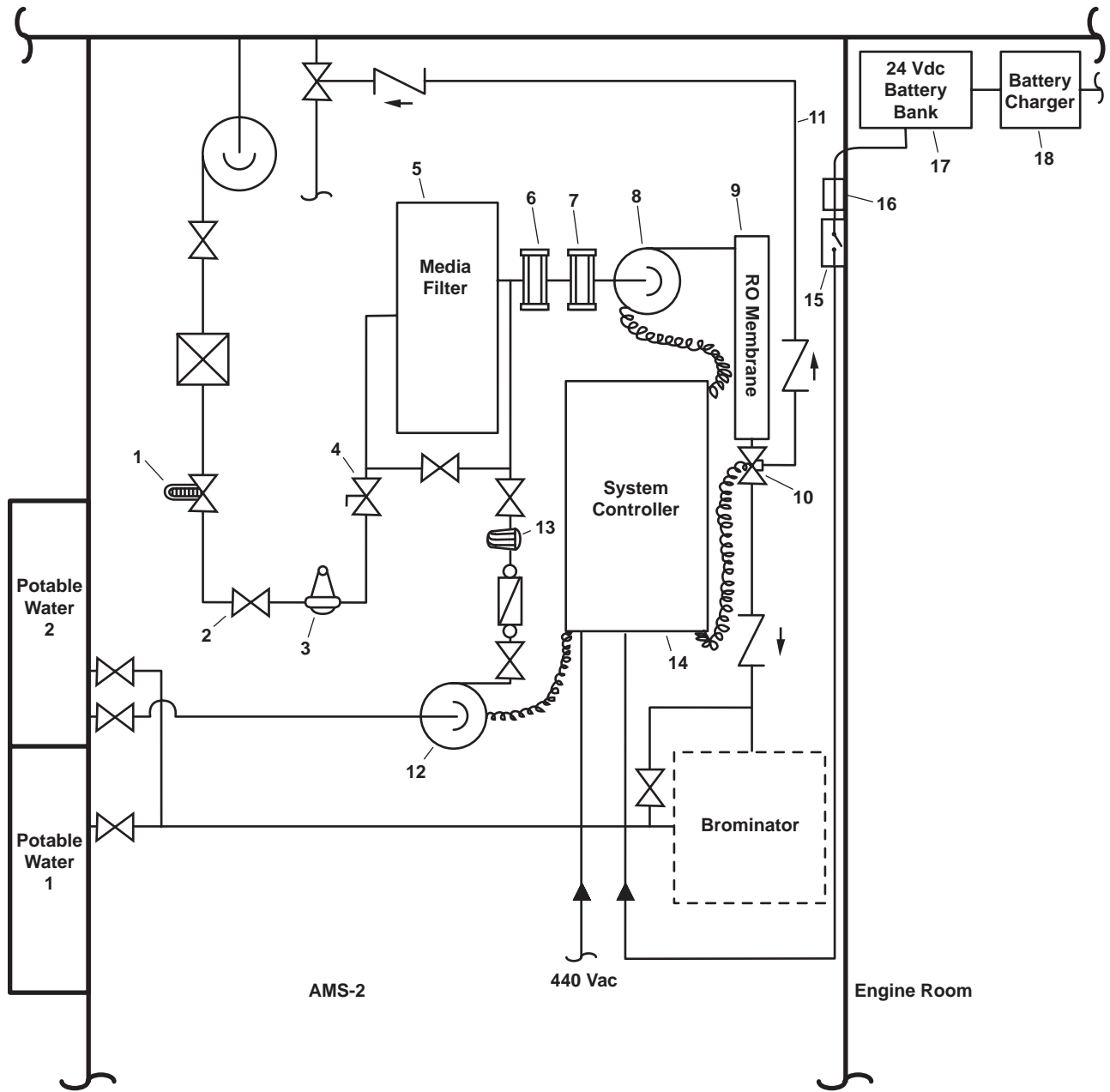

Figure 3. ROWPU System Diagram

END OF WORK PACKAGE

Chapter 2

Operator Instructions
for
Reverse Osmosis Water Purification Unit

Inland and Coastal Large Tug (LT)

OPERATOR, UNIT, DIRECT SUPPORT, AND GENERAL SUPPORT MAINTENANCE
 REVERSE OSMOSIS WATER PURIFICATION UNIT FOR
 INLAND AND COASTAL LARGE TUG (LT)
 DESCRIPTION AND USE OF OPERATOR CONTROLS AND INDICATORS

ROWPU SYSTEM CONTROLS AND INDICATORS

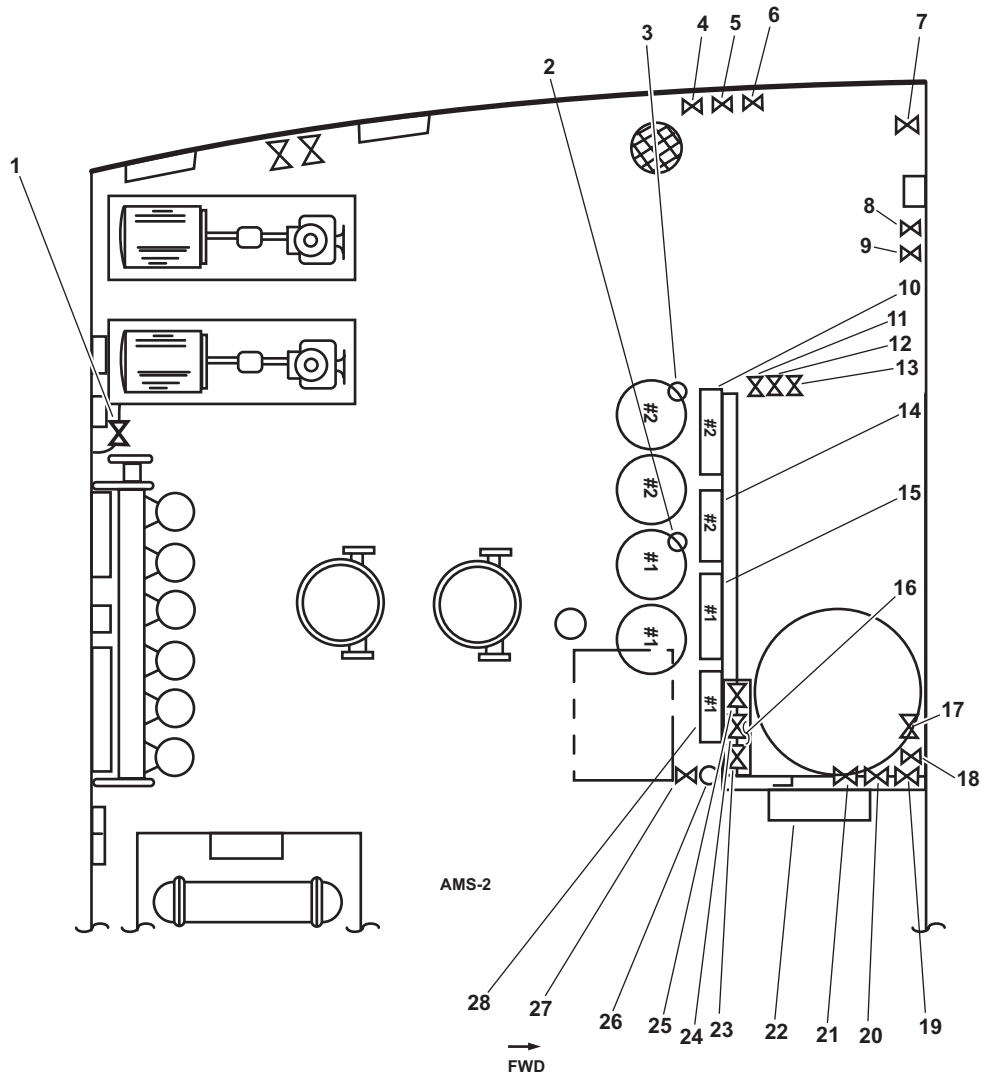

Figure 1. Reverse Osmosis Water Purification Unit (ROWPU) General Arrangement

Table 1. Reverse Osmosis Water Purification Unit (ROWPU) General Arrangement (refer to figure 1)

Key	Control/Indicator	Function
1	RO-V-9 ROWPU Auxiliary Fresh Water Pressure Pump Supply Valve	This valve controls the fresh water supplied for ROWPU flushing during maintenance cycles.
2	RO-PG-1-1 ROWPU 1 20-Micron Filter Outlet/ 5-Micron Filter Inlet Pressure Gauge	This gauge indicates pressure at the 5-micron filter inlet for ROWPU 1. It is used with the high pressure pump inlet pressure gauge to determine differential pressure across the 5-micron filter. Refer to figure 2.
3	RO-PG-2-1 ROWPU 2 20-Micron Filter Outlet/ 5-Micron Filter Inlet Pressure Gauge	This gauge indicates pressure at the 5-micron filter inlet for ROWPU 2. It is used with the high pressure pump inlet pressure gauge to determine differential pressure across the 5-micron filter. Refer to figure 2.
4	PW-38 BROMINATOR OUTLET	This valve controls the discharge flow from the brominator.
5	PW-36 BYPASS-BROMINATOR	This valve is OPEN to bypass the brominator.
6	PW-37 BROMINATOR INLET	This valve controls the flow of potable water into the brominator.
7	PW-84 POT. WTR. TO BROMINATOR	This valve is OPEN to permit the vessel's potable water to circulate through the brominator.
8	RO-V-7 Backflow Preventer Inlet Valve	This valve controls the flow of potable water into the backflow preventer.
9	RO-V-6 Backflow Preventer Discharge Valve	This valve controls the flow of potable water out of the backflow preventer.
10	ROWPU 2 Flow Control Panel	This panel contains the gauges needed to monitor the quantity and quality of the product water and the means to control overall system pressure for ROWPU 2. Refer to figure 3.
11	RO-V-1-2 ROWPU 1 Brine Discharge Valve	This valve controls the brine discharge from ROWPU 1.
12	RO-V-2-2 ROWPU 2 Brine Discharge Valve	This valve controls the brine discharge from ROWPU 2.
13	RO-V-8 Product Water Discharge Valve	This valve controls the flow of product water discharge from the ROWPUs.
14	ROWPU 2 System Controller	The system controller monitors the salt content of the product water by means of the salinity probe, and signals the 3-way diverter valve when potable water is being produced. The 3-way diverter valve and pump motors are all directly connected to and governed by the system controller. Refer to figure 4.
15	ROWPU 1 Flow Control Panel	This panel contains the gauges needed to monitor the quantity and quality of product water and the means to control overall system pressure for ROWPU 1. Refer to figure 3.

**Table 1. Reverse Osmosis Water Purification Unit (ROWPU) General Arrangement (refer to figure 1)
(continued)**

Key	Control/Indicator	Function
16	Media Filter Gauges and Valves	These gauges indicate pressure in the media filter, and the valves control the flow of water in and out of the media filter for maintenance and operational purposes. Refer to figure 5.
17	RO-V-10 Media Filter Backflush Discharge Valve	This valve permits the operator to purge the filtered contents of the media filter overboard if it becomes clogged. Refer to figure 6.
18	RO-V-11 Media Filter Drain Valve	This valve is opened to drain the media filter during maintenance.
19	RO-V-2 Media Filter Supply Valve	This valve controls the flow of raw water into the media filter. Refer to figure 6.
20	RO-V-3 Media Filter Discharge Valve	This valve controls the flow of filtered raw water out of the media filter. This valve is OPEN during normal ROWPU operation. Refer to figure 6.
21	RO-V-4 Media Filter Bypass Valve	This valve permits the operator to bypass the media filter during ROWPU operation and maintenance. Refer to figure 6.
22	440V Power Panel No. 5	This panel provides 440 Vac to the ROWPU system controllers. Refer to figure 7.
23	RO-V-1-1 ROWPU 1 Inlet Sea Water Supply Valve	This valve controls the flow of raw water from the media filter into the 20-micron filter basket for ROWPU 1. Refer to figure 2.
24	RO-V-5 ROWPU Cleaning Supply Valve	This valve permits the operator to pump cleaning solution and chemicals through the ROWPU during maintenance cycles. Refer to figure 2.
25	RO-V-2-1 ROWPU 2 Inlet Sea Water Supply Valve	This valve controls the flow of raw water from the media filter into the 20-micron filter basket for ROWPU 2. Refer to figure 2.
26	RO-PG-1 ROWPU General Service Pressure Gauge	This gauge indicates raw water pressure into the ROWPU system.
27	RO-V-1 Main Sea Water Supply Valve	This valve controls the flow of raw water into the ROWPU system.
28	ROWPU 1 System Controller	The controller monitors the salt content of the product water by means of the salinity probe, and signals the 3-way diverter valve when potable water is being produced. The 3-way diverter valve and pump motors are all directly connected to, and governed by, the system controller. Refer to figure 4.

FILTRATION SYSTEM CONTROLS AND INDICATORS

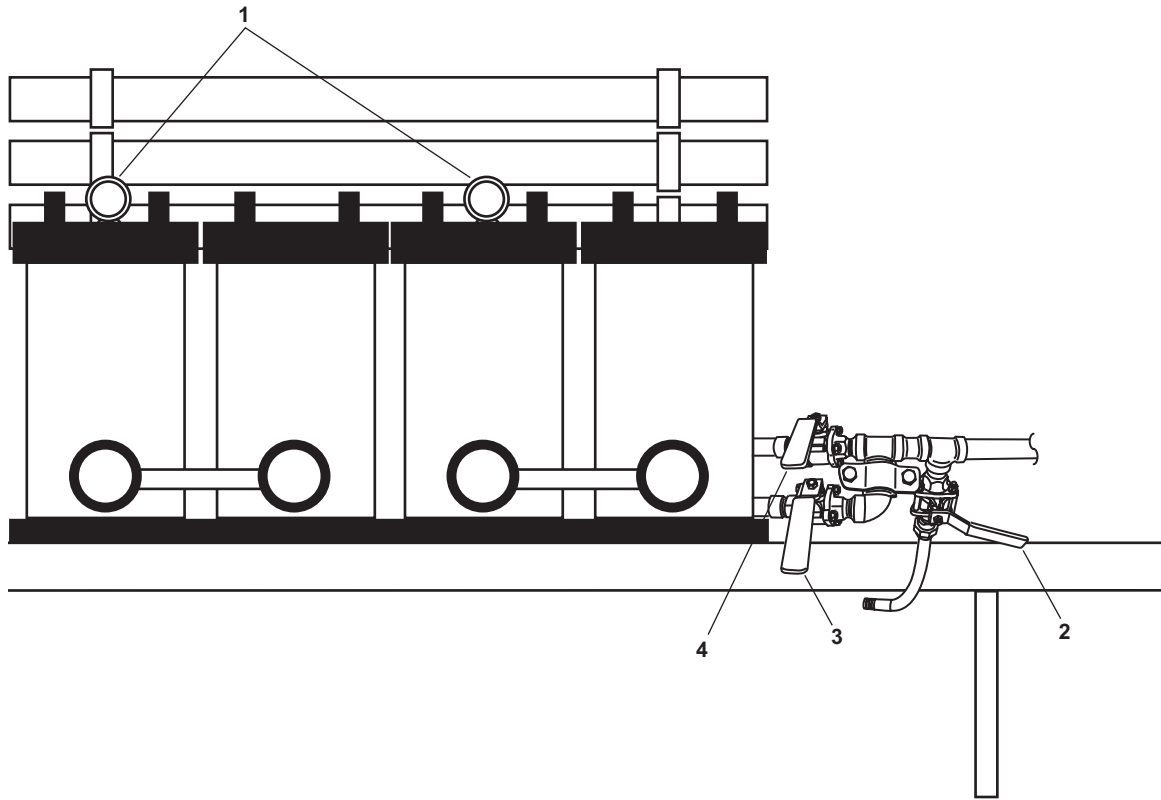

Figure 2. Filtration System Valves and Gauges

Table 2. Filtration System Valves and Gauges (refer to figure 2)

Key	Control/Indicator	Function
1	RO-PG-1-1 (RO-PG-2-1) ROWPU 1 (2) 5-Micron Filter Inlet Pressure Gauge	These gauges indicate pressure at the 5-micron filter inlet. It is used with the high pressure pump inlet pressure gauge to determine differential pressure across the 5-micron filter.
2	RO-V-5 ROWPU Cleaning Supply Valve	The cleaning supply valve controls the introduction of chemical cleaning and flushing solutions into the ROWPU during maintenance periods.
3	RO-V-1-1 ROWPU 1 Inlet Sea Water Supply Valve	This valve controls the flow of raw water into the ROWPU 1 20-micron filter basket.
4	RO-V-2-1 ROWPU 2 Inlet Sea Water Supply Valve	This valve controls the flow of raw water into the ROWPU 2 20-micron filter basket.

FLOW CONTROL PANEL CONTROLS AND INDICATORS

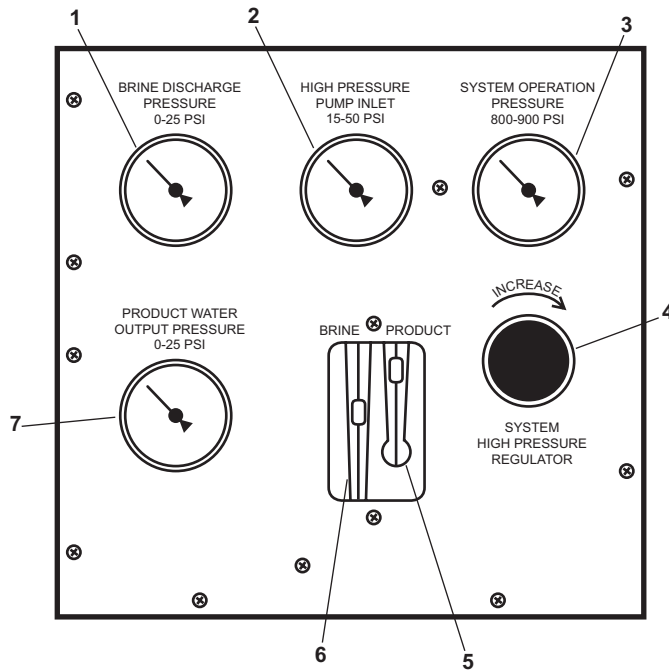

Figure 3. Flow Control Panel Controls and Indicators

Table 3. Flow Control Panel Controls and Indicators (refer to figure 3)

Key	Control/Indicator	Function
1	BRINE DISCHARGE PRESSURE Gauge	This gauge indicates the pressure in the brine discharge header.
2	HIGH PRESSURE PUMP INLET-PRESSURE Gauge	This gauge indicates the pressure at the high pressure pump inlet. It is used in combination with the 5-micron filter inlet pressure gauge to determine differential pressure across the 5-micron filter.
3	SYSTEM OPERATION PRESSURE Gauge	This gauge indicates the output pressure of the high pressure pump.
4	SYSTEM HIGH PRESSURE REGULATOR Valve	This valve controls the operating pressure in the ROWPU. The valve is turned clockwise to increase system pressure, and it is turned counterclockwise to decrease the system pressure.
5	PRODUCT Flow Meter	This flow meter indicates product water flow in gallons per hour. It also provides an indication of water quality being produced.
6	BRINE Flow Meter	This flow meter indicates the amount of brine that the ROWPU is expelling overboard.
7	PRODUCT WATER OUTPUT PRESSURE Gauge	This gauge indicates the pressure present in the product water line.

SYSTEM CONTROLLER CONTROLS AND INDICATORS

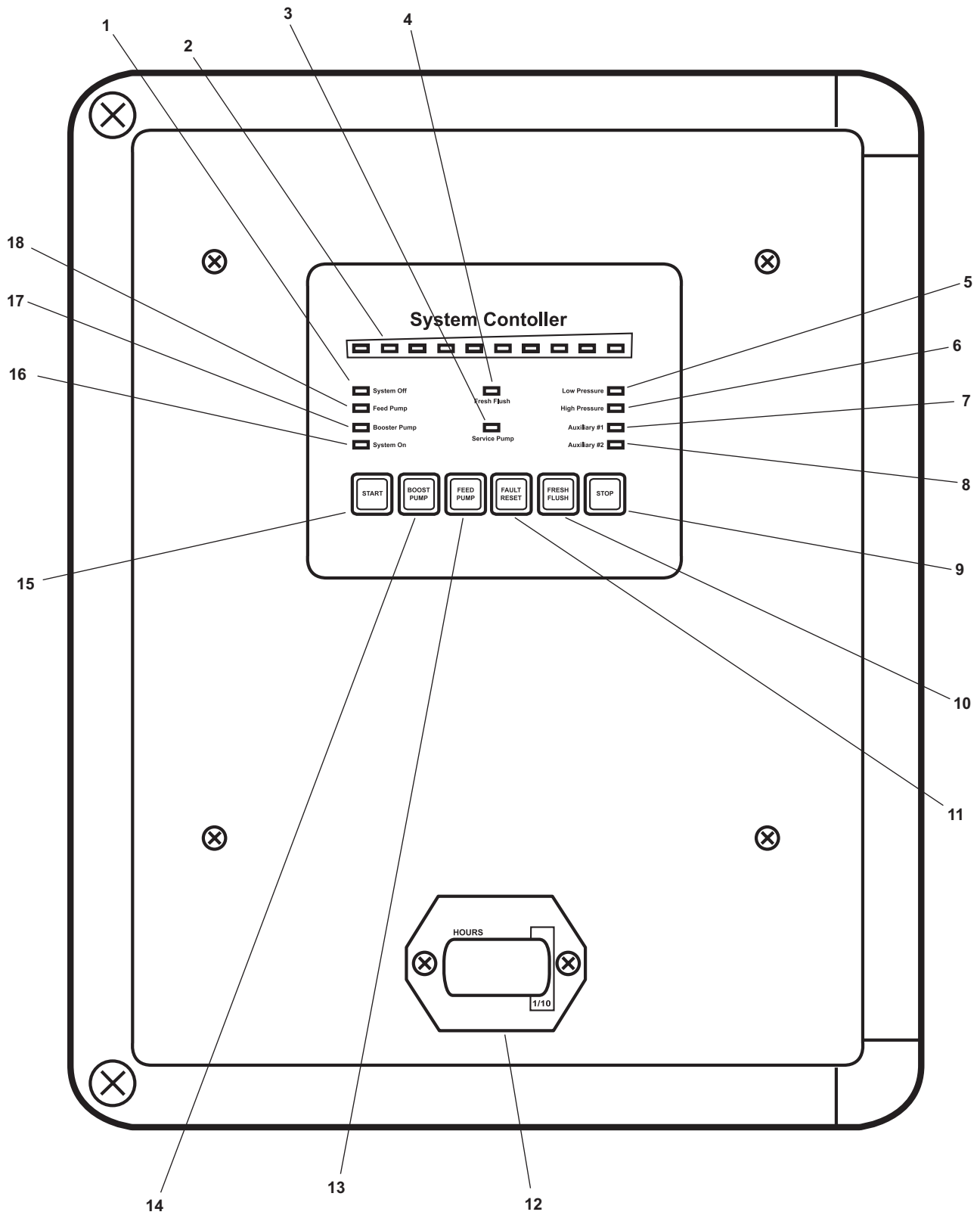

Figure 4. System Controller

Table 4. System Controller (refer to figure 4)

Key	Control/Indicator	Function
1	SYSTEM OFF Light Emitting Diode (LED)	This LED indicates no pumps or controlled processes are running, but that power is available to the ROWPU.
2	Salinity Meter	The salinity meter indicates product water salinity. The meter displays its increasing values left to right, and each lit LED indicates a value of 100 parts per million (PPM). The first three LED are green, followed by six yellow, and a single red.
3	SERVICE PUMP LED	The service pump fault LED illuminates when 500 hours have elapsed, and scheduled pump service is due.
4	FRESH FLUSH LED	This LED illuminates to indicate that the ROWPU fresh water flush cycle is in progress.
5	LOW PRESSURE LED	This LED illuminates to indicate that the ROWPU has shut down due to low raw water pressure at the high pressure pump inlet.
6	HIGH PRESSURE LED	This LED illuminates to indicate that the ROWPU has shut down due to excessive system operation pressure.
7	AUXILIARY #1 LED	This LED illuminates to indicate that the high pressure pump has shut down due to excessive internal temperature.
8	AUXILIARY #2 LED	This LED is not used on the vessel.
9	STOP Switch	This switch is pressed to halt the current operation, and to shut down the ROWPU during normal operation or in an emergency.
10	FRESH FLUSH Switch	This switch is pressed to begin the fresh water flush cycle during maintenance.
11	FAULT RESET Switch	This switch is pressed to reset the system fault that automatically shuts down the ROWPU.
12	Hour Meter	This meter registers the total operating hours of the system, and it assists the operator in following a regular scheduled maintenance program.
13	FEED PUMP Switch	This switch is not used on the vessel.
14	BOOST PUMP Switch	This switch is not used on the vessel.
15	START Switch	This is pressed to provide power to the high pressure pump, and to begin normal operation of the ROWPU.
16	SYSTEM ON LED	This LED illuminates to indicate that the ROWPU is operating normally, or that a controlled process is in progress.
17	BOOSTER PUMP LED	This LED illuminates to indicate that the high pressure pump is running.
18	FEED PUMP LED	This LED is not used on the vessel.

MEDIA FILTER CONTROLS AND INDICATORS

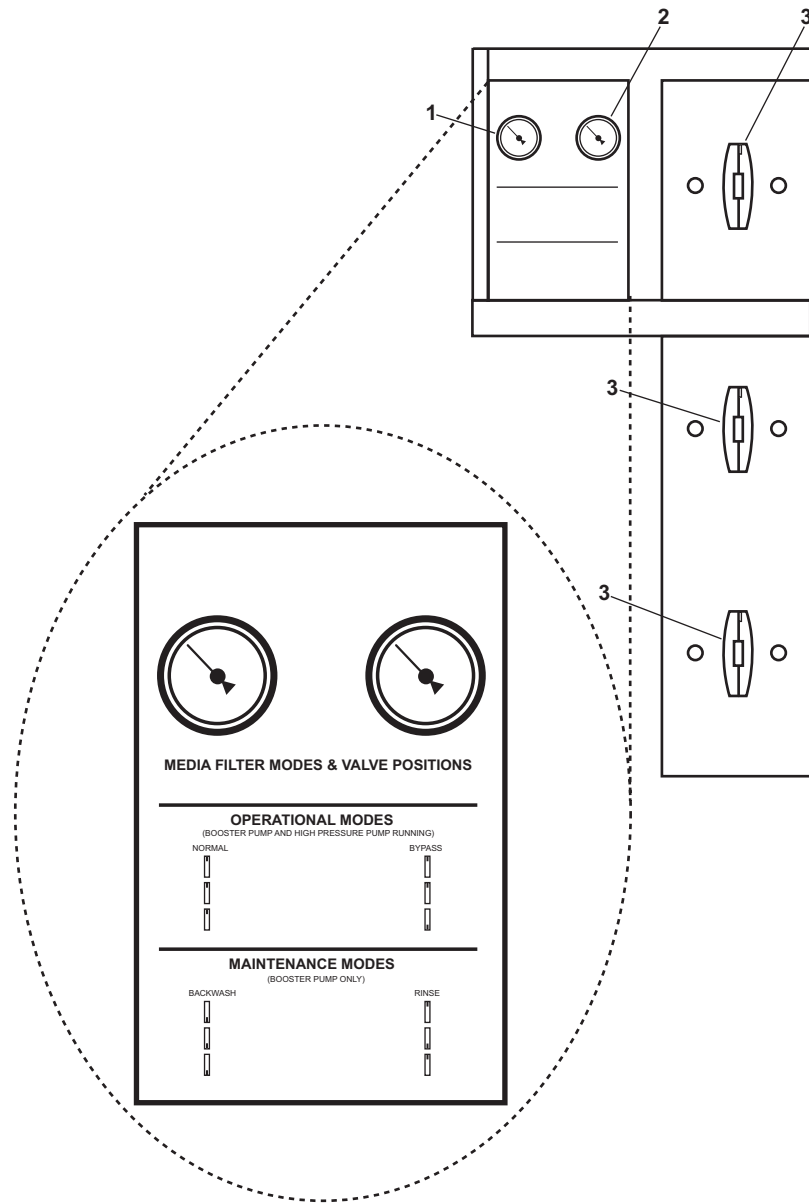

Figure 5. Media Filter Gauges and Maintenance Valves

Table 5. Media Filter Gauges and Maintenance Valves (refer to figure 5)

Key	Control/Indicator	Function
1	Media Filter INLET PRESSURE Gauge	This gauge indicates media filter inlet pressure.
2	Media Filter OUTLET PRESSURE Gauge	This gauge indicates media filter outlet pressure.
3	Media Filter Maintenance Manifold Valves	These valves allow the operator to control the various maintenance cycles associated with the media filter.

MEDIA FILTER VALVES

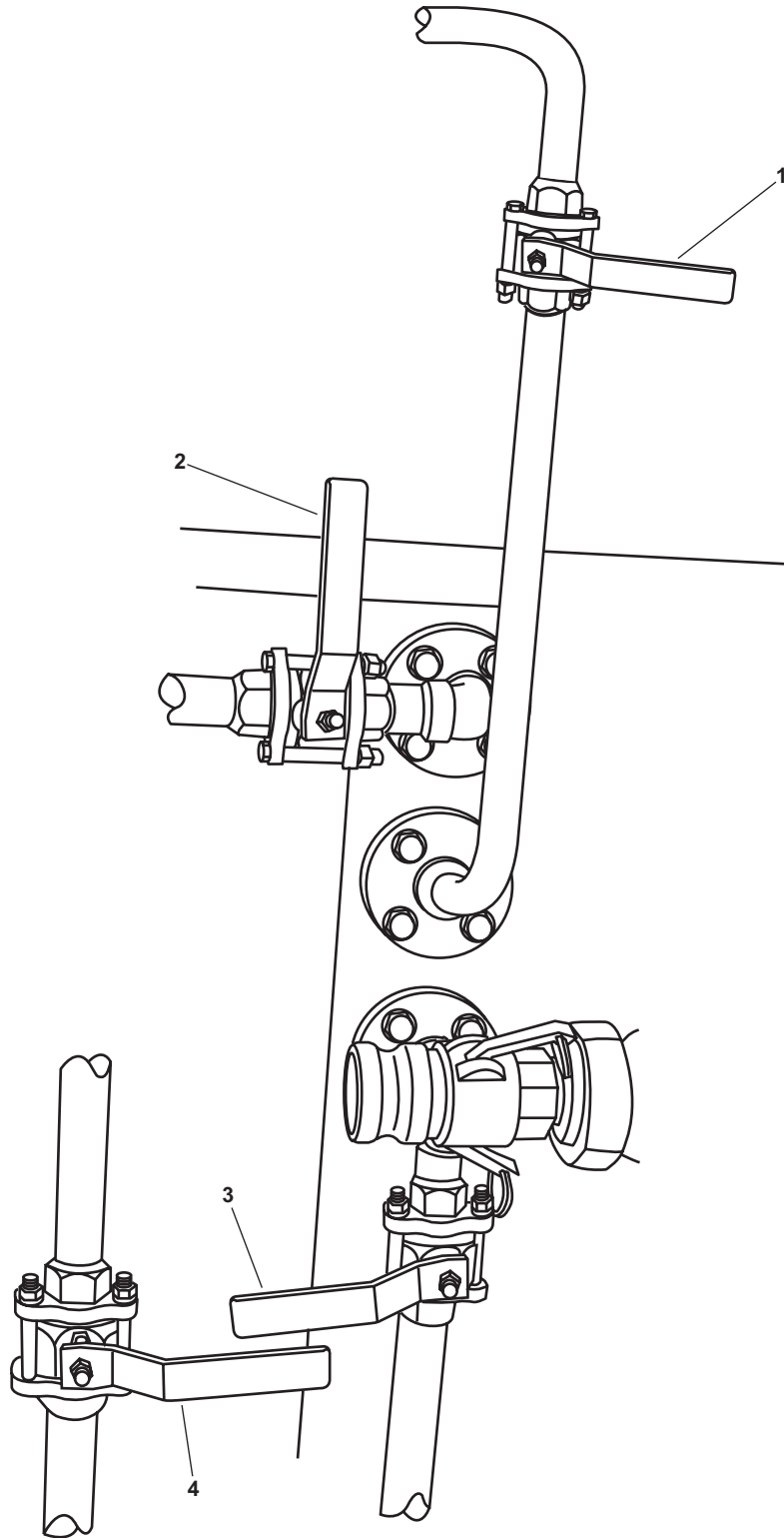

Figure 6. Media Filter Valves

Table 6. Media Filter Valves (refer to figure 6)

Key	Control/Indicator	Function
1	RO-V-10 Media Filter Backflush Discharge Valve	This valve allows the operator to purge the filtered contents of the media filter overboard if it becomes clogged.
2	RO-V-3 Media Filter Discharge Valve	This valve allows filtered raw water to exit the media filter. This valve is OPEN during normal ROWPU operation.
3	RO-V-2 Media Filter Supply Valve	This valve allows raw water to enter the media filter.
4	RO-V-4 Media Filter Bypass Valve	This valve permits the operator to bypass the media filter during ROWPU operation.

440V POWER PANEL NO. 5 CIRCUIT BREAKERS

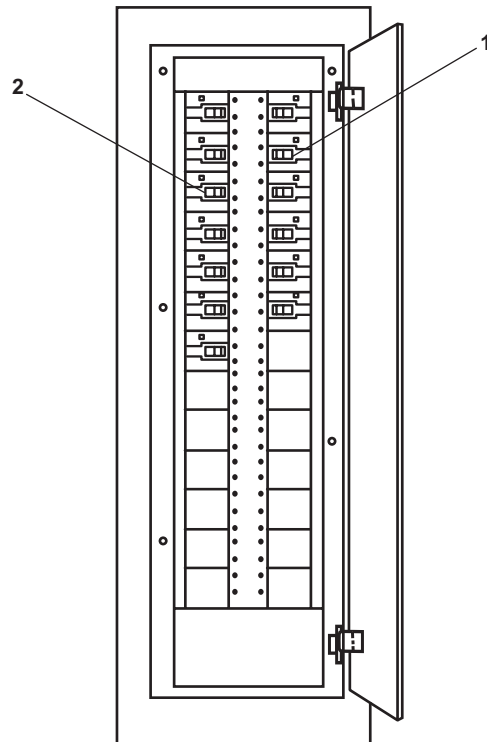

Figure 7. 440V Power Panel No. 5

Table 7. 440V Power Panel No. 5 (refer to figure 7)

Key	Control/Indicator	Function
1	REVERSE OSMOSIS WATER MAKER No. 1 Circuit Breaker (LT 803 Only) LVP FOR REVERSE OSMOSIS WATER MAKER No. 1 Circuit Breaker (All Other Vessels)	This circuit breaker provides 440 Vac to ROWPU 1.

Table 7. 440V Power Panel No. 5 (refer to figure 7) (continued)

Key	Control/Indicator	Function
2	REVERSE OSMOSIS WATER MAKER No. 2 Circuit Breaker (LT 803 Only) LVP FOR REVERSE OSMOSIS WATER MAKER No. 2 Circuit Breaker (All Other Vessels)	This circuit breaker provides 440 Vac to ROWPU 2.

24 VDC CONTROL PANEL CONTROLS AND INDICATORS

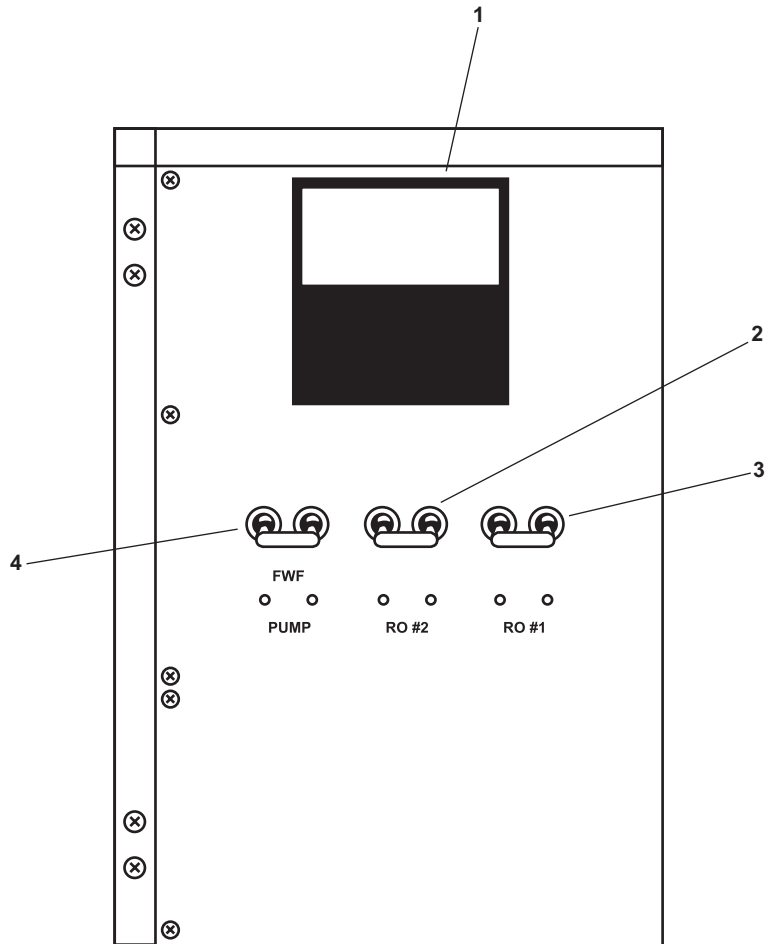

Figure 8. 24 Vdc Control Panel

Table 8. 24 Vdc Control Panel (refer to figure 8)

Key	Control/Indicator	Function
1	Voltmeter	This meter indicates the voltage available to the 24 Vdc control panel.
2	RO #2 Circuit Breaker	This circuit breaker provides circuit protection and control for ROWPU 2 circuits that use 24 Vdc.
3	RO #1 Circuit Breaker	This circuit breaker provides circuit protection and control for ROWPU 1 circuits that use 24 Vdc.
4	FWF PUMP Circuit Breaker	This circuit breaker provides circuit protection and control for the fresh water flush pump.

END OF WORK PACKAGE

**OPERATOR, UNIT, DIRECT SUPPORT, AND GENERAL SUPPORT MAINTENANCE
REVERSE OSMOSIS WATER PURIFICATION UNIT FOR
INLAND AND COASTAL LARGE TUG (LT)
OPERATION UNDER USUAL CONDITIONS**

INITIAL SETUP:**Personnel Required:**

One Watercraft Engineer, 88L

Equipment Conditions:General service system operating in normal mode
(TM 55-1925-273-10).**References:**

TM 55-1925-273-10

Potable water system operating in normal mode
(TM 55-1925-273-10).

SECURITY MEASURES FOR ELECTRONIC DATA

No electronic data is used or stored in the Reverse Osmosis Water Purification Unit (ROWPU).

STARTUP

System startup is accomplished by performing the following actions in the listed order:

1. Electrical/Piping Lineup
2. Media Filter Backflush
3. Align Media Filter for Normal Operation
4. Start ROWPU 1 and/or ROWPU 2 as necessary

ELECTRICAL/PIPING LINEUP

1. At the main switchboard in the EOS, set the following circuit breakers to ON:
 - a. AUX MACH SPACE NO.2 PWR PNL NO.5 (figure 1, item 1)
 - b. 3-25 KVA 1Ø XFMRS (figure 1, item 2)
2. At the engine room load center distribution panel, set the 120V DISTRIBUTION PANEL No. 4 circuit breaker (figure 2, item 1) **(LT 803 Only)** or (figure 3, item 1) **(All Other Vessels)** to ON.
3. At 120V distribution panel No. 4, set the ROWPU BATTERY CHARGER circuit breaker (figure 4, item 1) to ON.
4. At the ROWPU battery charger, turn ON the A.C. SWITCH (figure 5, item 1).
5. At the ROWPU 24 Vdc control panel, set the following circuit breakers to ON:
 - a. RO #1 (figure 6, item 1)
 - b. RO #2 (figure 6, item 2)
 - c. FWF PUMP (figure 6, item 3)
6. At 440V power panel No. 5, set the following circuit breakers to ON:
 - a. REVERSE OSMOSIS WATER MAKER No. 1 (figure 7, item 1) **(LT 803 Only)**
LVP FOR REVERSE OSMOSIS WATER MAKER No. 1 (figure 7, item 1) **(All Other Vessels)**
 - b. REVERSE OSMOSIS WATER MAKER No. 2 (figure 7, item 2) **(LT 803 Only)**
LVP FOR REVERSE OSMOSIS WATER MAKER No. 2 (figure 7, item 2) **(All Other Vessels)**

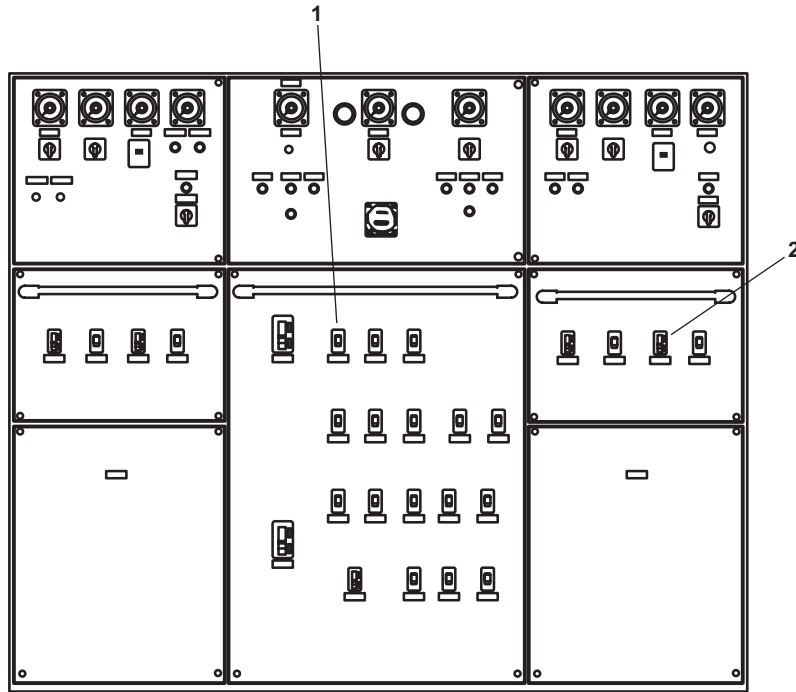

Figure 1. EOS Main Switchboard

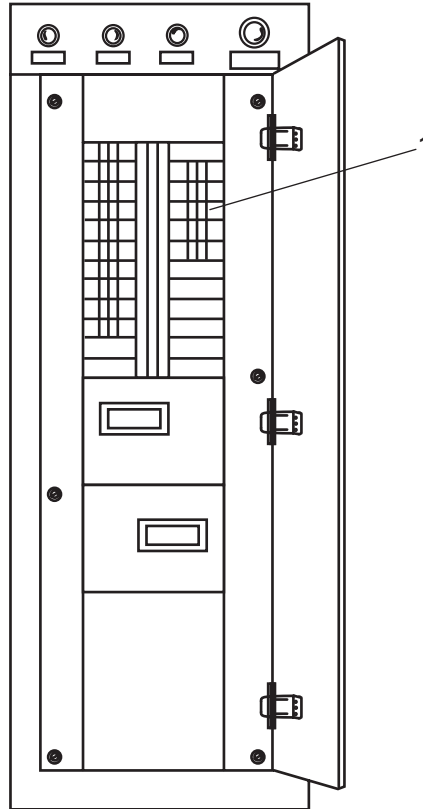

Figure 2. Load Center Distribution Panel (LT 803 Only)

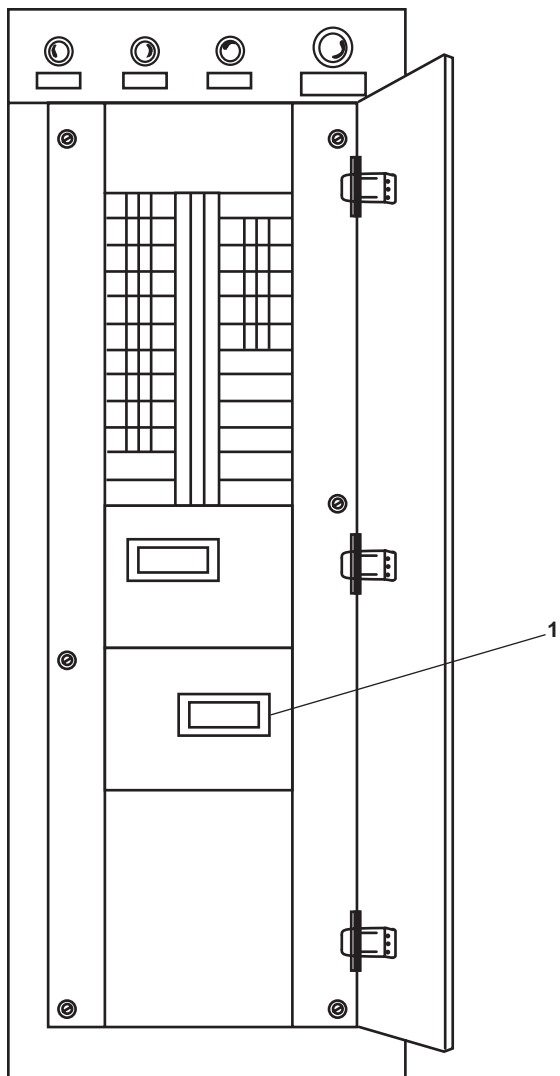

Figure 3. Load Center Distribution Panel (All Other Vessels)



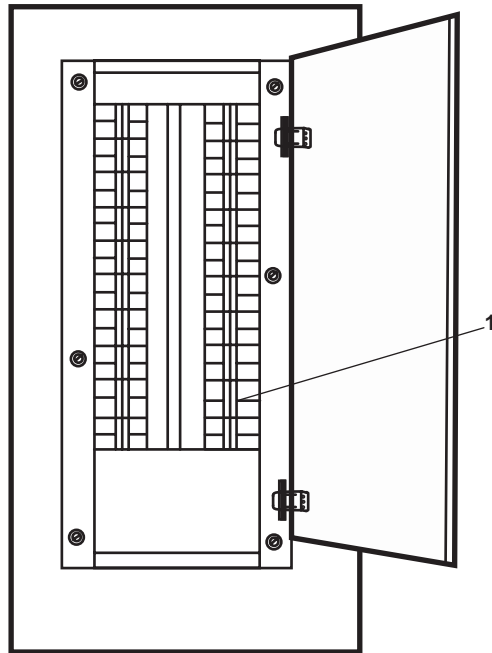

Figure 4. 120V Distribution Panel No. 4

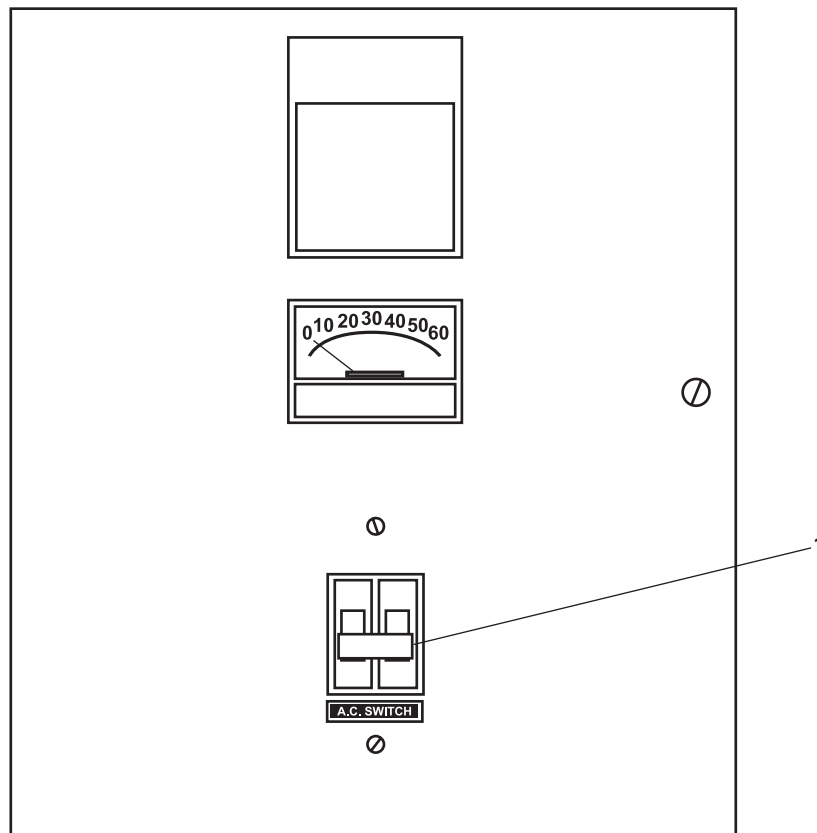

Figure 5. ROWPU Battery Charger

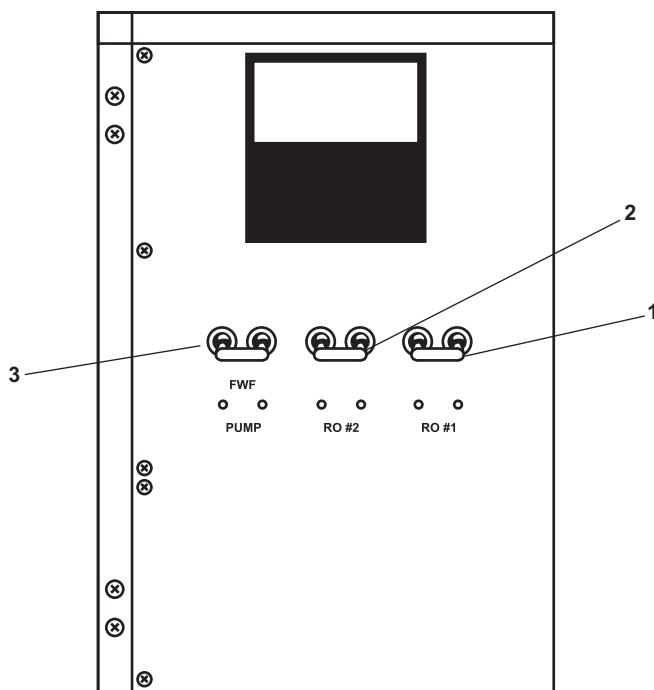

Figure 6. ROWPU 24 Vdc Control Panel

7. Verify that the general service system is online (TM 55-1925-273-10) and operating at a minimum pressure of 60 PSI (4.1 bar).
8. Verify that the brominator is online and operating normally (TM 55-1925-273-10), or that PW-36 BYPASS-BROMINATOR (figure 8, item 1) is OPEN.
9. CLOSE RO-V-1 (figure 9, item 1), main sea water supply.
10. OPEN the following valves:
 - a. RO-V-7 (figure 10, item 1), backflow preventer supply valve
 - b. RO-V-6, (figure 10, item 2), backflow preventer discharge valve
 - c. RO-V-9, (figure 11, item 1), fresh water flush pump supply valve
 - d. RO-V-1-2 (figure 12, item 1), ROWPU 1 brine discharge valve
 - e. RO-V-2-2 (figure 12, item 2), ROWPU 2 brine discharge valve
 - f. RO-V-8 (figure 12, item 3), product water discharge valve
 - g. PW-13 (figure 11, item 2), starboard potable water tank fill valve
 - h. PW-12 POT. WTR. TK. PORT FILL (figure 11, item 3).

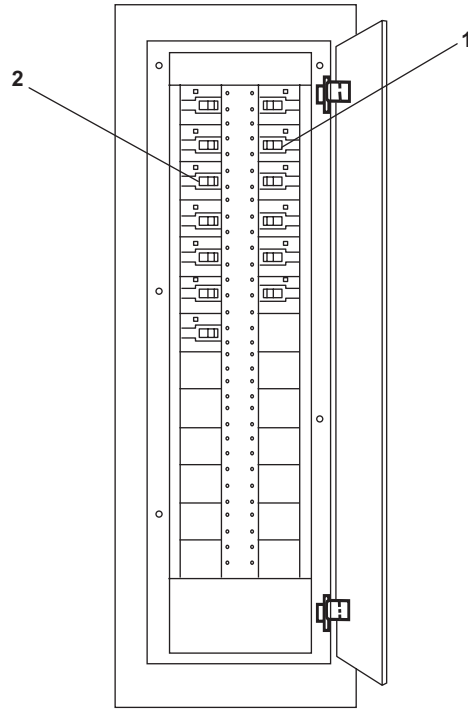

Figure 7. 440V Power Panel No. 5

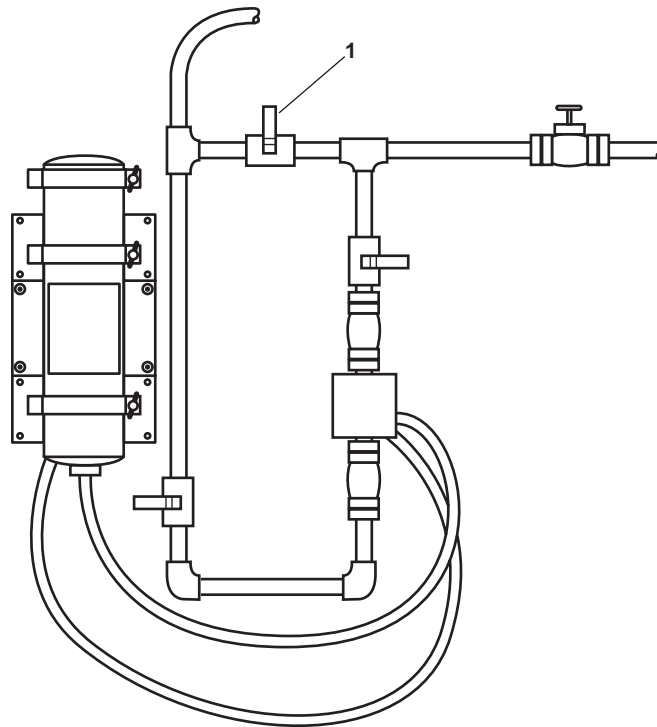

Figure 8. Brominator

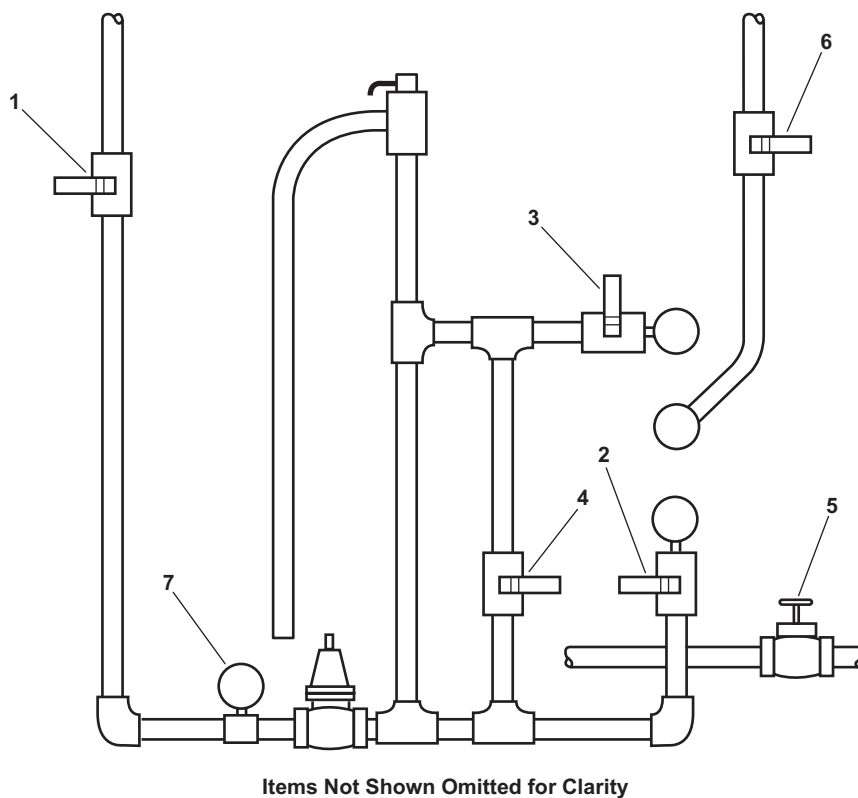

Figure 9. ROWPU System as Viewed from Starboard Side

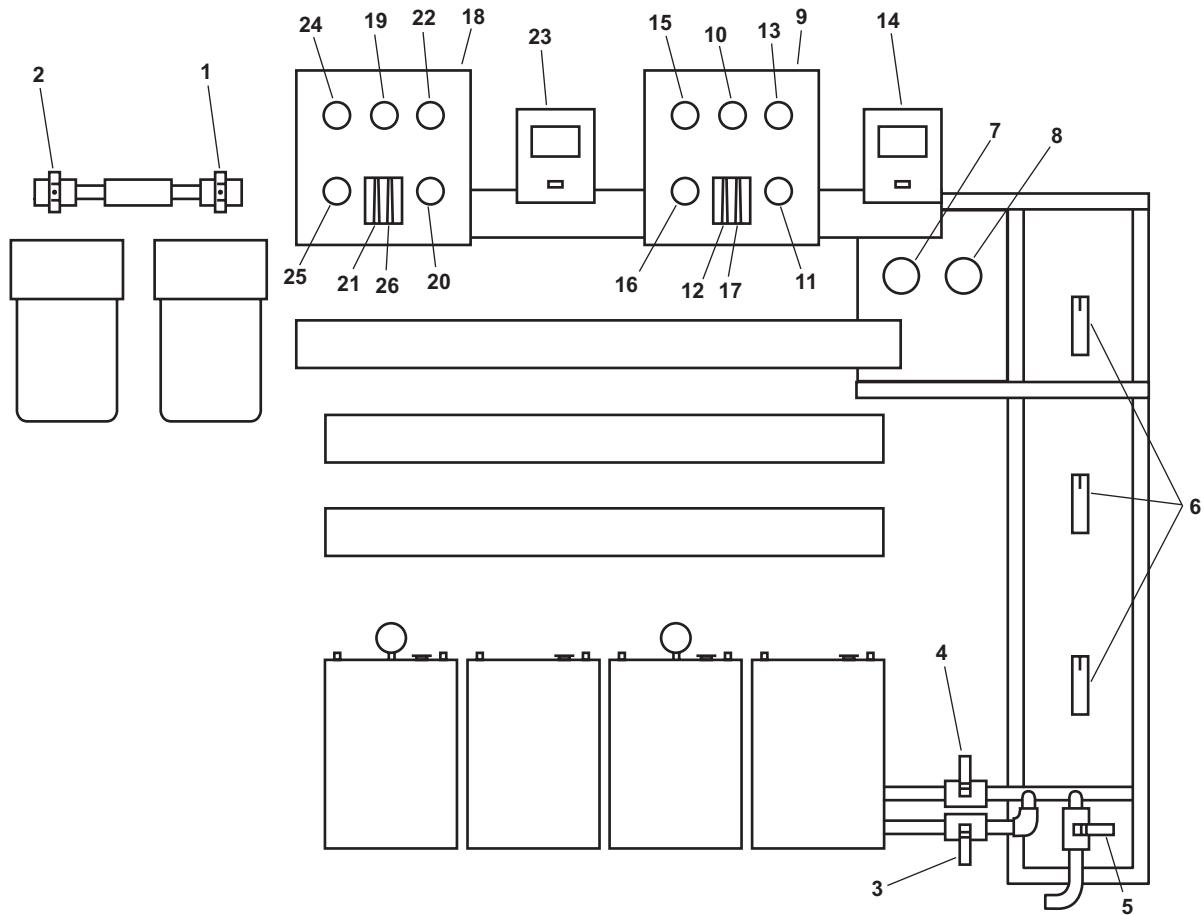

Figure 10. ROWPU System, Front View

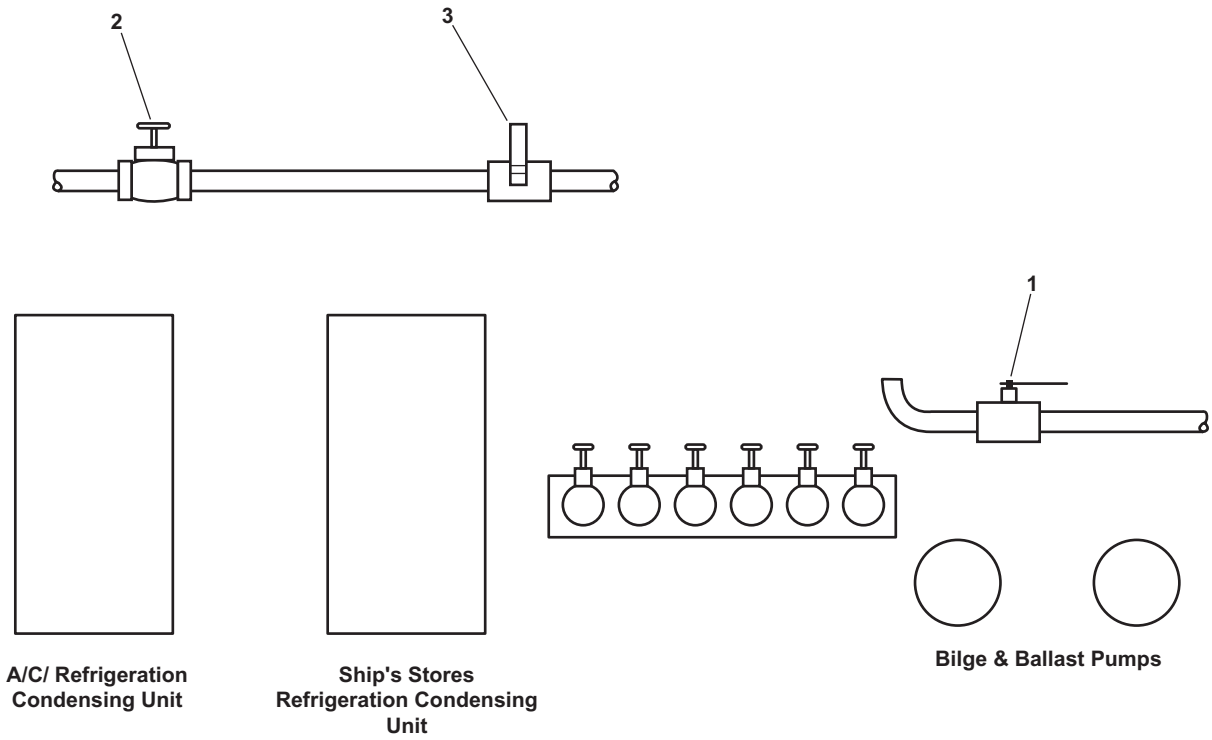

Figure 11. Potable Water Valves on AMS 2 Aft Bulkhead

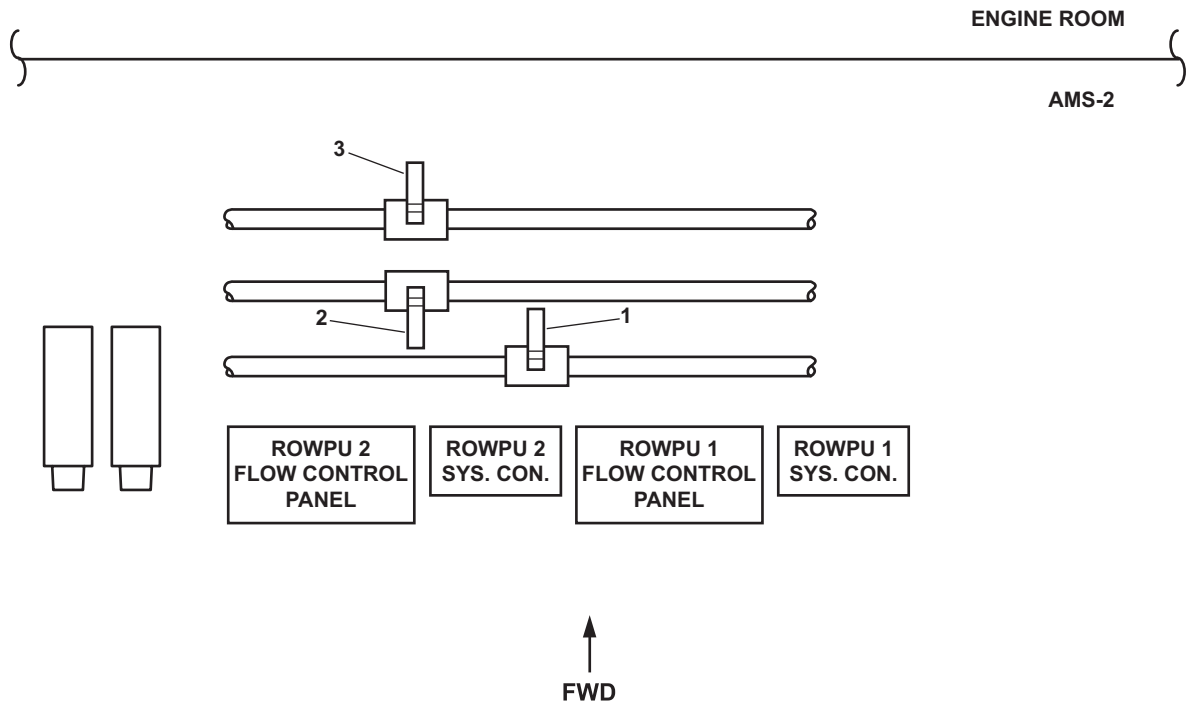

Figure 12. ROWPU System Valves as Viewed from Above

MEDIA FILTER BACKFLUSH**NOTE**

Always perform the media filter backflush procedure before and after all ROWPU operations. If differential pressure exceeds 20 PSI (1.4 bar) as indicated by the difference between the media filter INLET PRESSURE and OUTLET PRESSURE gauges, secure ROWPU operation, and perform media filter backflush.

1. CLOSE the following valves:
 - a. RO-V-2 (figure 9, item 2), media filter supply
 - b. RO-V-3 (figure 9, item 3), media filter discharge
 - c. RO-V-1-1 (figure 10, item 3), ROWPU 1 inlet sea water supply
 - d. RO-V-2-1 (figure 10, item 4), ROWPU 2 inlet sea water supply
 - e. RO-V-4 (figure 9, item 4), media filter bypass
 - f. RO-V-5 (figure 10, item 5), cleaning supply
 - g. RO-V-11 (figure 9, item 5), media filter drain
2. OPEN the following valves:
 - a. RO-V-10 (figure 9, item 6), media filter backflush valve
 - b. RO-V-1 (figure 9, item 1), main sea water supply
3. Verify that RO-PG-1 (figure 9, item 7), general service pressure, indicates a minimum of 30 PSI (2.4 bar).

 **CAUTION**

Media tank inlet pressure must not exceed 45 PSI (3.1 bar) and differential pressure must not exceed 35 PSI (2.4 bar), or damage could occur to the media filter tank.

4. Align the media filter maintenance mode valves (figure 10, item 6) to the "BACKWASH" position as shown in figure 13.
5. Slowly OPEN RO-V-2 (figure 9, item 2), media filter supply, to backwash the media filter.
6. Verify that the media filter INLET PRESSURE gauge (figure 10, item 7) does not exceed 45 PSI (3.1 bar).
7. Verify that the pressure differential between the media filter INLET PRESSURE gauge (figure 10, item 7) and the media filter OUTLET PRESSURE gauge (figure 10, item 8) does not exceed 20 PSI (2.4 bar).
8. BACKWASH the media filter for a minimum of 10 minutes, or until differential pressure between the media filter INLET PRESSURE gauge (figure 10, item 7) and the media filter OUTLET PRESSURE gauge (figure 10, item 8) is less than 5 PSI (0.3 bar).
9. CLOSE RO-V-2 (figure 9, item 2), media filter supply.
10. Align the media filter maintenance mode valves (figure 10, item 6) to the "RINSE" position as shown in figure 13.

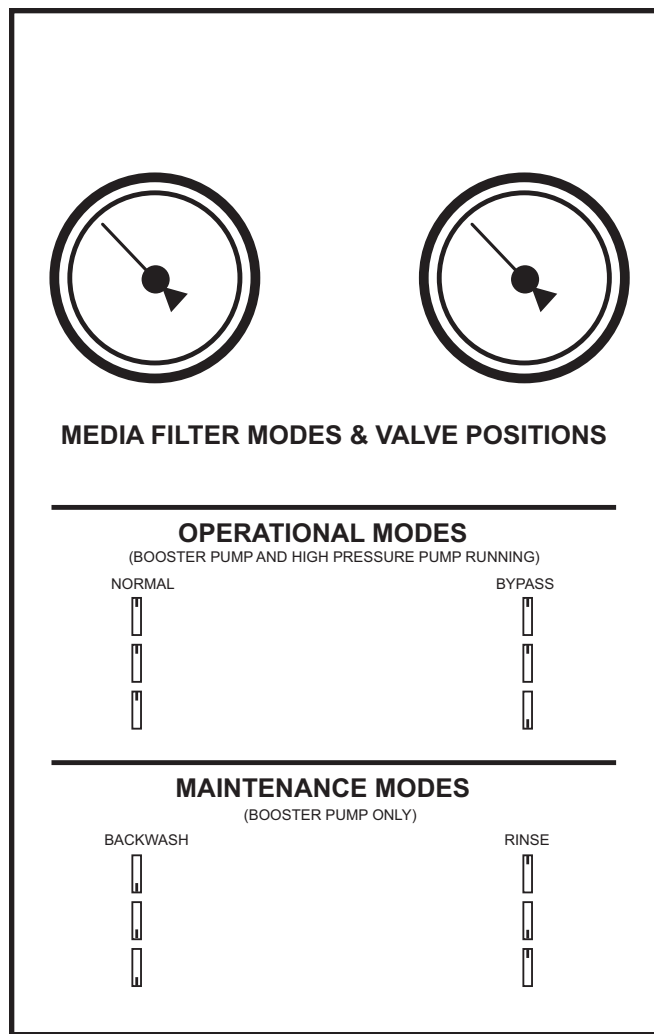

Figure 13. Media Filter Maintenance Mode Valve Positions

11. Slowly OPEN RO-V-2 (figure 9, item 2), media filter supply.
12. RINSE the media filter for a minimum of 5 minutes.
13. CLOSE RO-V-2 (figure 9, item 2), media filter supply.
14. Align the media filter for normal operation by closing the following valves:
 - a. RO-V-2 (figure 9, item 2), media filter supply
 - b. RO-V-4 (figure 9, item 4), media filter bypass
 - c. RO-V-10 (figure 9, item 6), media filter backflush valve
 - d. RO-V-5 (figure 10, item 5), cleaning supply
15. OPEN RO-V-3 (figure 9, item 3), media filter discharge
16. Align the media filter maintenance mode valves (figure 10, item 6) to the "NORMAL" position as shown in figure 13.

ROWPU 1 STARTUP **CAUTION**

If bypassing the media filter, RO-PG-1-1, 20-micron filter outlet/5-micron filter inlet pressure should not exceed 45 PSI (3.1 bar), or damage could occur.

1. OPEN the following valves:
 - a. RO-V-1-1 (figure 10, item 3), ROWPU 1 inlet sea water supply
 - b. RO-V-1 (figure 9, item 1), main sea water supply
 - c. RO-V-3 (figure 9, item 3), media filter discharge
2. Slowly OPEN RO-V-2 (figure 9, item 2), media filter supply.
3. At ROWPU 1 flow control panel (figure 10, item 9), perform the following:
 - a. Verify that the HIGH PRESSURE PUMP INLET pressure gauge (figure 10, item 10) indicates a minimum of 10 PSI (0.7 bar).

 **CAUTION**

Failure to completely OPEN the SYSTEM HIGH PRESSURE REGULATOR valve prior to starting the high pressure pump will result in damage to the reverse osmosis membranes.

- b. Fully OPEN the SYSTEM HIGH PRESSURE REGULATOR valve, RO-V-1-3 (figure 10, item 11).
 - c. Observe the BRINE flow meter (figure 10, item 12) until it displays a minimum reading of 1 gal/min (3.8 l/min) with few or no bubbles present.
 - d. Verify that the SYSTEM OPERATION PRESSURE gauge (figure 10, item 13) does not rise above 50 PSI (3.4 bar).
4. At the ROWPU 1 system controller (figure 10, item 14), perform the following:
 - a. Press the STOP pushbutton (figure 14, item 1), and verify that the SYSTEM OFF indicator (figure 14, item 2) is illuminated.
 - b. Press the START pushbutton (figure 14, item 3) and verify the following:
 - (1) BOOSTER PUMP indicator (figure 14, item 4) illuminates.
 - (2) SYSTEM ON indicator (figure 14, item 5) is illuminated.
5. Verify the following conditions at the ROWPU 1 flow control panel (figure 10, item 9):
 - a. The BRINE flow meter (figure 10, item 12) displays a minimum flow reading of 4 gallons (15.1 liters) per minute with no bubbles present.
 - b. The BRINE DISCHARGE PRESSURE gauge (figure 10, item 15) indicates less than 15 PSI (1 bar).
 - c. The PRODUCT WATER OUTPUT PRESSURE gauge (figure 10, item 16) indicates approximately 0 PSI (0.0 bar).

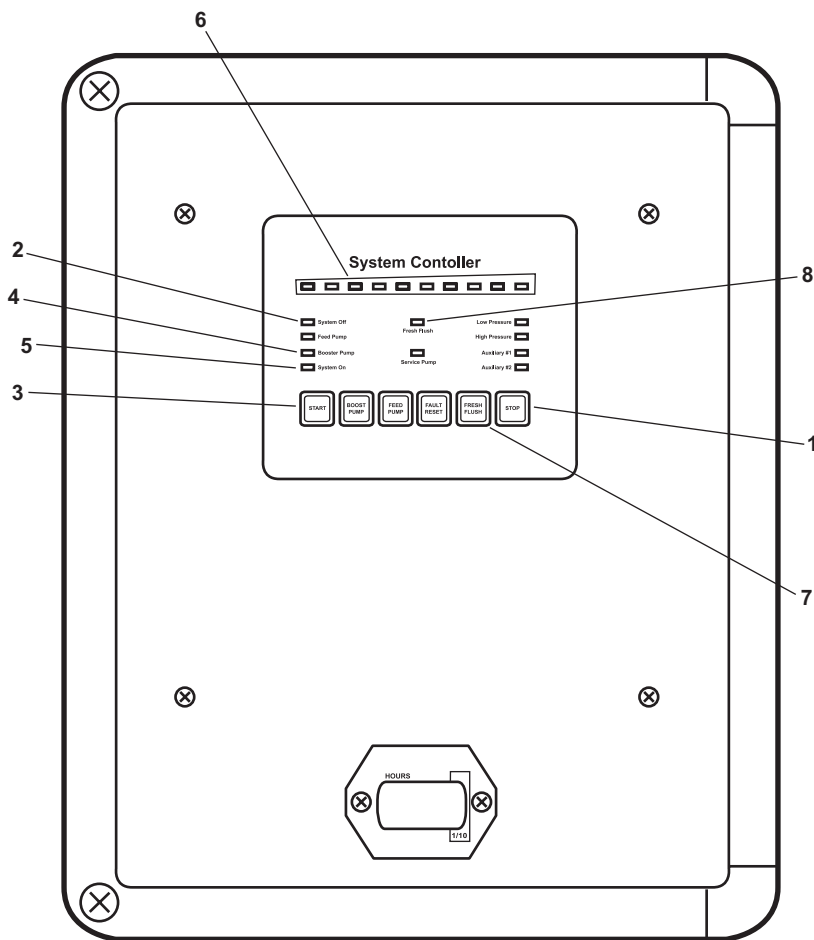

Figure 14. System Controller

- d. The SYSTEM OPERATION PRESSURE gauge (figure 10, item 13) indicates less than 50 PSI (3.4 bar).
 - e. The PRODUCT WATER flow meter (figure 10, item 17) indicates less than 1 gallon (3.8 liters) per hour.
6. Allow the system to operate in this configuration for approximately two minutes. Ensure that all gauges stabilize, and most of the air is purged from the system as indicated by a fluid stream with few or no bubbles flowing through the BRINE flow meter (figure 10, item 12).

▲ CAUTION

Increase system pressure slowly. Failure to comply with this caution will cause damage to the reverse osmosis membranes.

7. At ROWPU 1 flow control panel (figure 10, item 9), slowly increase system pressure by rotating the SYSTEM HIGH PRESSURE REGULATOR valve, RO-V-1-3 (figure 10, item 11) in the INCREASE direction until the SYSTEM OPERATION PRESSURE gauge (figure 10, item 13) indicates 400 PSI (27.6 bar).
8. Allow the system to operate in this configuration for approximately two minutes. Ensure that all gauges stabilize and that most of the air is purged from the system as indicated by fluid streams with few or no bubbles flowing through the BRINE flow meter (figure 10, item 12) and the PRODUCT WATER flow meter (figure 10, item 17).

 **CAUTION**

Increase system pressure slowly. Failure to comply with this caution will cause damage to the reverse osmosis membranes.

9. At ROWPU 1 flow control panel (figure 10, item 9), slowly increase system pressure by rotating the SYSTEM HIGH PRESSURE REGULATOR valve, RO-V-1-3 (figure 10, item 11) in the INCREASE direction until the SYSTEM OPERATION PRESSURE gauge (figure 10, item 13) indicates 650 PSI (44.8 bar).
10. Allow the system to operate in this configuration for approximately two minutes. Ensure that all gauges stabilize, and that all air bubbles are purged from the system as indicated by solid fluid streams flowing through the BRINE flow meter (figure 10, item 12) and the PRODUCT WATER flow meter (figure 10, item 17).

 **CAUTION**

ROWPU maximum safe operating pressure is 950 PSI (65.5 bar). The system high pressure cutout is set at 950 PSI (65.5 bar) \pm 25 PSI (1.7 bar). Do not exceed 900 PSI (62.1 bar) as indicated by the SYSTEM OPERATION PRESSURE gauge, or damage to the ROWPU system could occur.

NOTE

The ROWPU maximum operating pressure is directly related to seawater temperature and salinity. The maximum operating pressure may be lower than 900 PSI (62.1 bar), depending on seawater temperature and salinity.

11. At ROWPU 1 flow control panel (figure 10, item 9), slowly adjust system pressure by rotating the SYSTEM HIGH PRESSURE REGULATOR valve, RO-V-1-3 (figure 10, item 11) as necessary until the PRODUCT WATER flow meter (figure 10, item 17) indicates 66 gallons (249.8 liters) per hour, to a maximum 900 PSI (62.1 bar) as indicated by the SYSTEM OPERATION PRESSURE gauge (figure 10, item 13).
12. Verify that the ROWPU 1 gauges and indicators stabilize as follows:
 - a. At ROWPU 1 flow control panel (figure 10, item 9), verify the following:

 **CAUTION**

If bypassing the media filter, RO-PG-1-1, 20-micron filter outlet/5-micron filter inlet pressure gauge, should not exceed 45 PSI (3.1 bar), or damage could occur.

- (1) HIGH PRESSURE PUMP INLET pressure gauge (figure 10, item 10) indicates a minimum of 10 PSI (0.7 bar) and a maximum of 45 PSI (3.1 bar).
- (2) The SYSTEM OPERATION PRESSURE gauge (figure 10, item 13) indicates less than 900 PSI (62.1 bar).
- (3) The PRODUCT WATER OUTPUT PRESSURE gauge (figure 10, item 16) indicates less than 20 PSI (1.4 bar).
- (4) The BRINE DISCHARGE PRESSURE gauge (figure 10, item 15) indicates approximately 10 PSI (0.7 bar).
- (5) The BRINE flow meter (figure 10, item 12) indicates approximately 3.2 gallons (12.1 liters) per minute.

- (6) The PRODUCT WATER flow meter (figure 10, item 17) indicates approximately 66 gallons (248.8 liters) per hour.
- b. At the ROWPU 1 system controller (figure 10, item 14), verify that the SALINITY METER (figure 14, item 6) indicates that product water salinity is less than 500 parts per million (ppm), as indicated by five or fewer LEDs lit.

ROWPU 2 STARTUP

CAUTION

If bypassing the media filter, RO-PG-2-1, 20-micron filter outlet/5-micron filter inlet pressure, should not exceed 45 PSI (3.1 bar) or damage could occur.

1. OPEN the following valves:
 - a. RO-V-2-1 (figure 10, item 4), ROWPU 2 inlet sea water supply
 - b. RO-V-1 (figure 9, item 1), main sea water supply
 - c. RO-V-3 (figure 9, item 3), media filter discharge
2. Slowly OPEN RO-V-2 (figure 9, item 2), media filter supply.
3. Complete the following actions at ROWPU 2 flow control panel (figure 10, item 18):
 - a. Verify that the HIGH PRESSURE PUMP INLET pressure gauge (figure 10, item 19) indicates a minimum of 10 PSI (0.7 bar).

CAUTION

Failure to completely OPEN the SYSTEM HIGH PRESSURE REGULATOR valve prior to starting the high pressure pump will result in damage to the reverse osmosis membranes.

- b. Fully OPEN the SYSTEM HIGH PRESSURE REGULATOR valve, RO-V-2-3 (figure 10, item 20).
 - c. Observe the BRINE flow meter (figure 10, item 21) until it displays a minimum reading of 1 gal/min (3.8 l/min) with few or no bubbles present.
 - d. Verify that the SYSTEM OPERATION PRESSURE gauge (figure 10, item 22) does not rise above 50 PSI (3.4 bar).
4. At the ROWPU 2 system controller (figure 10, item 23), perform the following:
 - a. Press the STOP pushbutton (figure 14, item 1), and verify that the SYSTEM OFF indicator (figure 14, item 2) is illuminated.
 - b. Press the START pushbutton (figure 14, item 3), and verify the following:
 - (1) BOOSTER PUMP indicator (figure 14, item 4) illuminates.
 - (2) SYSTEM ON indicator (figure 14, item 5) is illuminated.

5. At the ROWPU 2 flow control panel (figure 10, item 18), verify the following:
 - a. The BRINE flow meter (figure 10, item 21) displays a flow reading of 4 gallons (15.1 liters) per minute with no bubbles present.
 - b. The BRINE DISCHARGE PRESSURE gauge (figure 10, item 24) indicates less than 15 PSI (1 bar).
 - c. The PRODUCT WATER OUTPUT PRESSURE gauge (figure 10, item 25) indicates approximately 0 PSI (0.0 bar).
 - d. The SYSTEM OPERATION PRESSURE gauge (figure 10, item 22) indicates less than 50 PSI (3.4 bar).
 - e. The PRODUCT WATER flow meter (figure 10, item 26), indicates less than 1 gallon (3.8 liters) per hour.
6. Allow the system to operate in this configuration for approximately two minutes. Ensure that all gauges stabilize, and that most of the air is purged from the system as indicated by a fluid stream with few or no bubbles flowing through the BRINE flow meter (figure 10, item 21).

 **CAUTION**

Increase system pressure slowly. Failure to comply with this caution will cause damage to the reverse osmosis membranes.

7. At ROWPU 2 flow control panel (figure 10, item 18), slowly increase system pressure by rotating the SYSTEM HIGH PRESSURE REGULATOR valve, RO-V-2-3 (figure 10, item 20) in the INCREASE direction until the SYSTEM OPERATION PRESSURE gauge (figure 10, item 22) indicates 400 PSI (27.6 bar).
8. Allow the system to operate in this configuration for approximately two minutes. Ensure that all gauges stabilize, and that most of the air is purged from the system as indicated by fluid streams with few or no bubbles flowing through the BRINE flow meter (figure 10, item 21) and the PRODUCT WATER flow meter (figure 10, item 26).
9. At ROWPU 2 flow control panel (figure 10, item 18), slowly increase system pressure by rotating the SYSTEM HIGH PRESSURE REGULATOR valve, RO-V-2-3 (figure 10, item 20) in the INCREASE direction until the SYSTEM OPERATION PRESSURE gauge (figure 10, item 22) indicates 650 PSI (44.8 bar).
10. Allow the system to operate in this configuration for approximately two minutes. Ensure that all gauges stabilize, and that all air bubbles are purged from the system as indicated by solid fluid streams flowing through the BRINE flow meter (figure 10, item 21) and the PRODUCT WATER flow meter (figure 10, item 26).

 **CAUTION**

ROWPU maximum safe operating pressure is 950 PSI (65.5 bar). The system high pressure cutout is set at 950 PSI (65.5 bar) \pm 25 PSI (1.7 bar). Do not exceed 900 PSI (62.1 bar) as indicated by the SYSTEM OPERATION PRESSURE gauge, or damage to the ROWPU system could occur.

NOTE

The ROWPU maximum operating pressure is directly related to seawater temperature and salinity. The maximum operating pressure may be lower than 900 PSI (62.1 bar), depending on seawater temperature and salinity.

11. At ROWPU 2 flow control panel (figure 10, item 18), slowly adjust system pressure by rotating the SYSTEM HIGH PRESSURE REGULATOR valve, RO-V-2-3 (figure 10, item 20) as necessary until the PRODUCT WATER flow meter (figure 10, item 26), indicates 33 gallons (125 liters) per hour, to a maximum 900 PSI (62.1 bar) as indicated by the SYSTEM OPERATION PRESSURE gauge (figure 10, item 22).

12. Verify that the ROWPU 2 gauges and indicators stabilize as follows:

- a. At ROWPU 2 flow control panel (figure 10, item 18), verify the following:

 **CAUTION**

If bypassing the media filter, RO-PG-2-1, 20-micron filter outlet/5-micron filter inlet pressure gauge should not exceed 45 PSI (3.1 bar), or damage could occur.

- (1) HIGH PRESSURE PUMP INLET pressure gauge (figure 10, item 19) indicates a minimum of 10 PSI (0.7 bar) and a maximum of 45 PSI (3.1 bar).
 - (2) The SYSTEM OPERATION PRESSURE gauge (figure 10, item 22) indicates 900 PSI (62.1 bar) or less.
 - (3) The PRODUCT WATER OUTPUT PRESSURE gauge (figure 10, item 25) indicates less than 20 PSI (1.4 bar).
 - (4) The BRINE DISCHARGE PRESSURE gauge (figure 10, item 24) indicates approximately 10 PSI (0.7 bar).
 - (5) The BRINE flow meter (figure 10, item 21) indicates approximately 3.5 gallons (12.1 liters) per minute.
 - (6) The PRODUCT WATER flow meter (figure 10, item 26) indicates approximately 33 gallons (124.9 liters) per hour.
- b. At the ROWPU 2 system controller (figure 10, item 23), verify that the SALINITY METER (figure 14, item 6) indicates product water salinity is less than 500 parts per million (ppm), as indicated by five or fewer LEDs lit.

ROWPU 1 SHUTDOWN

1. At the ROWPU 1 flow control panel (figure 10, item 9), perform the following:
 - a. Slowly decrease system pressure by rotating the SYSTEM HIGH PRESSURE REGULATOR valve, RO-V-1-3 (figure 10, item 11) in the counterclockwise direction to the fully OPEN position.
 - b. Observe that the SYSTEM OPERATION PRESSURE gauge (figure 10, item 13) indicates less than 50 PSI (3.4 bar).
2. At the ROWPU 1 system controller (figure 10, item 14), perform the following:
 - a. Press the STOP pushbutton (figure 14, item 1).
 - b. Observe that the BOOSTER PUMP indicator (figure 14, item 4) goes out.
 - c. Observe that the SYSTEM OFF indicator (figure 14, item 2) illuminates.
3. CLOSE RO-V-1-1 (figure 10, item 3), ROWPU 1 inlet sea water supply.
4. At 440V power panel No. 5, set the REVERSE OSMOSIS WATER MAKER No. 1 circuit breaker (**LT 803 Only**) or the LVP FOR REVERSE OSMOSIS WATER MAKER No. 1 circuit breaker (**All Other Vessels**) (figure 7, item 1) to the OFF position.

ROWPU 2 SHUTDOWN

1. At the ROWPU 2 flow control panel (figure 10, item 18), perform the following:
 - a. Slowly decrease system pressure by rotating the SYSTEM HIGH PRESSURE REGULATOR valve, RO-V-2-3 (figure 10, item 20), in the counterclockwise direction to the fully OPEN position.
 - b. Observe that the SYSTEM OPERATION PRESSURE gauge (figure 10, item 22) indicates less than 50 PSI (3.4 bar).
2. At the ROWPU 2 system controller (figure 10, item 23), perform the following:
 - a. Press the STOP pushbutton (figure 14, item 1).
 - b. Observe that the BOOSTER PUMP indicator (figure 14, item 4) goes out.
 - c. Observe that the SYSTEM OFF indicator (figure 14, item 2) illuminates.
3. CLOSE RO-V-2-1 (figure 10, item 4), ROWPU 2 inlet sea water supply.
4. At 440V power panel No. 5, set the REVERSE OSMOSIS WATER MAKER No. 2 circuit breaker (**LT 803 Only**) or the LVP FOR REVERSE OSMOSIS WATER MAKER No. 2 circuit breaker (**All Other Vessels**) (figure 7, item 2) to the OFF position.

ROWPU SYSTEM SHUTDOWN **CAUTION**

Perform ROWPU system shutdown only when both ROWPU 1 and ROWPU 2 are secured, and both high pressure pumps are OFF. Equipment damage could result from improper shutdown procedures.

1. Ensure that both high pressure pumps are OFF by verifying that the SYSTEM OFF indicators (figure 14, item 2) are lit at the ROWPU 1 system controller (figure 10, item 14) and the ROWPU 2 system controller (figure 10, item 23).
2. CLOSE the following valves:
 - a. RO-V-1 (figure 9, item 1), main sea water supply
 - b. RO-V-2 (figure 9, item 2), media filter supply
 - c. RO-V-3 (figure 9, item 3), media filter discharge
 - d. RO-V-8 (figure 12, item 3), product water discharge
3. At AMS 2 power panel 5, set the following circuit breakers to the OFF position:
 - a. REVERSE OSMOSIS WATER MAKER No. 1 (figure 7, item 1) (**LT 803 Only**)
LVP FOR REVERSE OSMOSIS WATER MAKER No. 1 (figure 7, item 1) (**All Other Vessels**)
 - b. REVERSE OSMOSIS WATER MAKER No. 2 (figure 7, item 2) (**LT 803 Only**)
LVP FOR REVERSE OSMOSIS WATER MAKER No. 2 (figure 7, item 2) (**All Other Vessels**)
4. Perform the Media Filter Backflush procedure as detailed earlier in this work package.

ROWPU FRESH WATER FLUSH**NOTE**

Always perform a fresh water flush after ROWPU operations and at least once a week when the ROWPU is in layup.

1. Perform the ROWPU system shutdown procedure as detailed earlier in this work package.

⚠ CAUTION

If the valves detailed in the fresh water flush procedure are not closed, the fresh water flush will not be effective, and the service life of the reverse osmosis membrane elements will be shortened.

2. CLOSE the following valves:
 - a. RO-V-1-1 (figure 10, item 3), ROWPU 1 inlet sea water supply
 - b. RO-V-2-1 (figure 10, item 4), ROWPU 2 inlet sea water supply
3. OPEN the following valves:
 - a. RO-V-9 (figure 11, item 1), fresh water flush pump supply
 - b. RO-V-6 (figure 10, item 2), backflow preventer discharge
 - c. RO-V-7 (figure 10, item 1), backflow preventer supply
 - d. OPEN the FRESH WATER FLUSH PUMP OUTLET valve (figure 15, item 1).

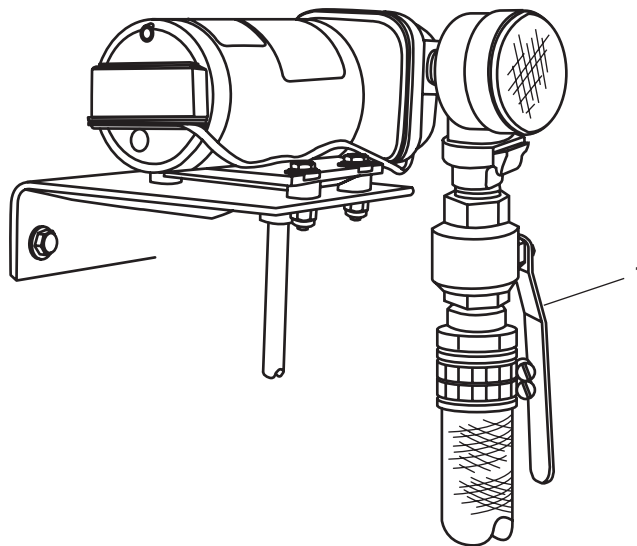

Figure 15. Fresh Water Flush Pump Outlet Valve

4. At the ROWPU 1 system controller (figure 10, item 14) and the ROWPU 2 system controller (figure 10, item 23), perform the following:
 - a. Verify that the SYSTEM OFF indicators (figure 14, item 2) are lit.
 - b. Press the FRESH FLUSH pushbuttons (figure 14, item 7).
 - c. Observe that the FRESH FLUSH indicators (figure 14, item 8) are lit.
 - d. Verify that the fresh water flush pump starts.

NOTE

During fresh water flush cycles, a brine flow meter reading of less than 1 gallon (3.8 liters) per minute is an indication that the charcoal filters may be clogged. Clogged charcoal filters can cause shortened service life of the reverse osmosis membrane elements.

5. At each flow control panel (figure 10, items 9 and 18), verify that the BRINE flow meters (figure 10, items 12 and 21) indicate a flow rate of approximately 1 gallon (3.8 liters) per minute each during the fresh water flush cycle.

ROWPU SYSTEM LAYUP

1. Perform the ROWPU system shutdown procedure as detailed earlier in this work package.
2. Perform the media filter backflush procedure as detailed earlier in this work package.
3. Perform the ROWPW fresh water flush procedure as detailed earlier in this work package.
4. Upon completion of the fresh water flush cycles, observe the following indications at the ROWPU 1 system controller (figure 10, item 14) and at the ROWPU 2 system controller (figure 10, item 23):

NOTE

During ROWPU system layup cycles, the FRESH FLUSH indicator blinks occasionally to inform the operator that the layup cycle is active.

- a. FRESH FLUSH (figure 14, item 8) indicators blinking occasionally.

NOTE

During ROWPU system layup cycles, the SALINITY METER acts as a system clock and counts down from seven to zero indicating the number of days remaining until the next fresh water flush cycle.

- b. Verify that the SALINITY METER (figure 14, item 6) displays number of days until next fresh water flush cycle.

END OF WORK PACKAGE

**OPERATOR, UNIT, DIRECT SUPPORT, AND GENERAL SUPPORT MAINTENANCE
REVERSE OSMOSIS WATER PURIFICATION UNIT FOR
INLAND AND COASTAL LARGE TUG (LT)
OPERATION UNDER UNUSUAL CONDITIONS**

INITIAL SETUP:**Personnel Required:**

One Watercraft Engineer, 88L

SECURITY MEASURES FOR ELECTRONIC DATA

No electronic data is used or stored in the Reverse Osmosis Water Purification system (ROWPU).

UNUSUAL ENVIRONMENT/WEATHER

The ROWPU may be operated when the ambient raw water temperature is between 33 and 118 °F (0.6 and 47.8 °C) with a maximum salinity content of 65,000 ppm. These conditions cover all navigable waters in which the Large Tug (LT) is capable of operating. The ROWPU is designed to operate continuously at 900 PSI (62.1 bar). The system high pressure cutout is set at 950 PSI (65.5 bar) ± 25 PSI (1.7 bar). Normal benchmark readings for performance are based upon a raw water temperature of 77 °F (25 °C) with a salinity content of 35,000 ppm. Although the ROWPU is designed to operate in all navigable oceans, special considerations must be made by the operator if raw water conditions stray too far from center. The variables the operator must take into consideration are salinity, temperature, and system operating pressure.

SALINITY

The ROWPU will produce product water at 100% of rated capacity up to a salinity content of 38,000 ppm. As seen in table 1, when the salinity content of the raw water exceeds 40,000 ppm, the operator will notice a decline in the production of product water. This is normal. Do not attempt to increase the rate of product water production by increasing system operating pressure, or damage could occur to the ROWPU. Conversely, the operator will notice that the ROWPU will easily exceed 100% of rated capacity in brackish water. The operator must take action to lower system operation pressure so that the ROWPU does not exceed 100% of rated capacity.

TEMPERATURE

At temperatures close to freezing, water molecules are less active, and it is more difficult for the water molecules to pass across the reverse osmosis membrane. The operator should notice that the colder the raw water, the less product water that can be produced. This is normal, and the operator is reminded to never exceed maximum safe operating pressure. Conversely, in warmer water the ROWPU could easily exceed 100% rated capacity. This is normal, and the operator must decrease the system operation pressure so that 100% rated capacity is not exceeded. Table 2 is used to estimate the effect of temperature on ROWPU product water production.

SYSTEM OPERATING PRESSURE

The upper limit of the ROWPU maximum safe operating pressure is 950 PSI (65.5 bar). The operator should never exceed 900 PSI (62.1 bar) as indicated on the system operation pressure gauges. The ROWPU is designed to produce product water at 100% of rated capacity at 900 PSI (62.1 bar). Table 3 demonstrates that as raw water temperature increases, the system pressure must be adjusted so that the system does not exceed 100% of rated capacity. Product water flow greater than rated capacity will cause premature fouling of the Reverse Osmosis (RO) membrane elements.

Table 1. Effects of Salinity on ROWPU Production

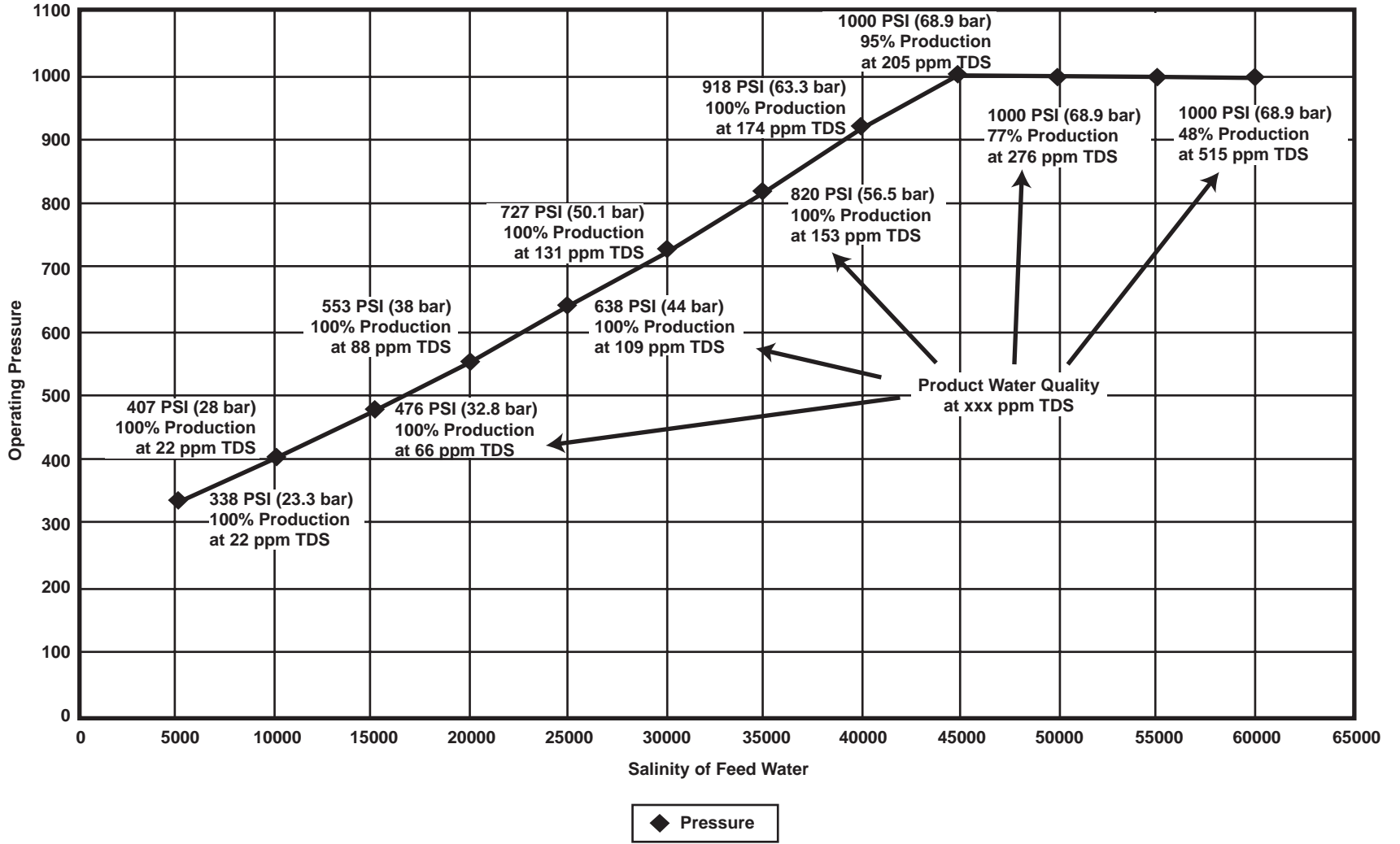

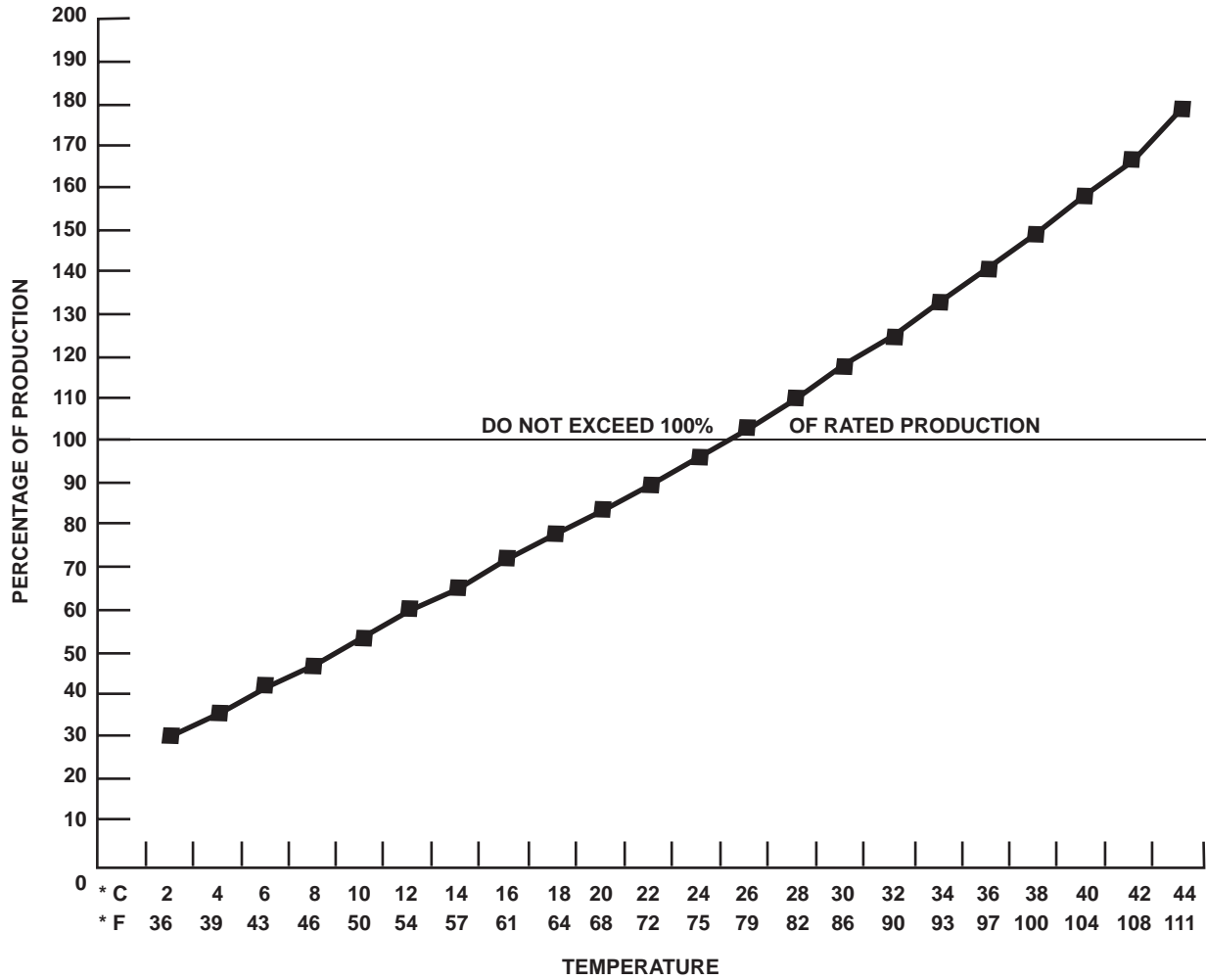

Table 2. Effects of Temperature on ROWPU Production

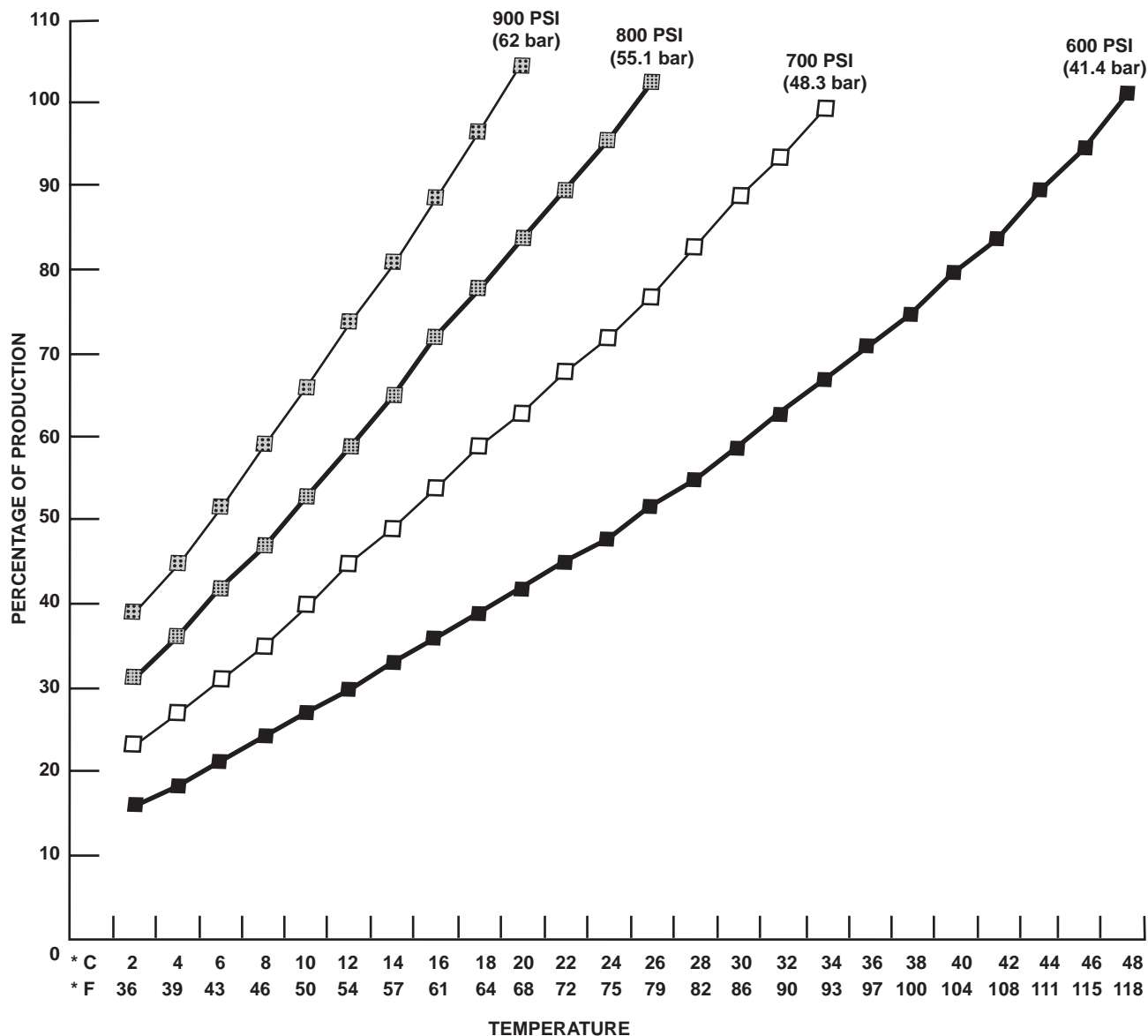

Table 3. Raw Water Temperature and Pressure Effects

EMERGENCY PROCEDURES

The LT is fitted with two ROWPUs. Each ROWPU is capable of operating as a stand-alone unit. In the event of a casualty to one unit, the unaffected unit can be operated continuously until repairs are made.

END OF WORK PACKAGE

Chapter 3

**Troubleshooting Procedures
for
Reverse Osmosis Water Purification Unit
Inland and Coastal Large Tug (LT)**

**OPERATOR AND UNIT MAINTENANCE
REVERSE OSMOSIS WATER PURIFICATION UNIT FOR
INLAND AND COASTAL LARGE TUG (LT)
TROUBLESHOOTING INDEX**

USE OF THE INDEX

Troubleshooting begins by identifying the equipment and the malfunction. Table 1 contains the operator troubleshooting procedures, and table 2 contains the unit troubleshooting procedures. The equipment list is contained in the left column of the tables, and the malfunctions are listed in the center column of the tables. Once the correct equipment and malfunction are located, look immediately to the right for the work package and procedure that correspond to the malfunction. After locating the appropriate work package and procedure, turn to that procedure, and follow the instructions in the paragraph that follows.

USE OF TROUBLESHOOTING PROCEDURES

Functional flow logic tree troubleshooting procedures are used for all troubleshooting procedures in this manual. In this troubleshooting style, a pill shaped symbol (figure 1) is used to depict the beginning or end point of a procedure. Decision points are depicted by diamond shaped symbols (figure 2). Action points, as well as warnings, cautions, and notes are contained in rectangular symbols (figure 3). Procedures that are too large for one page are joined together by the circular shaped connector symbols (figure 4). The connector symbol will denote which page and step to go to (or come from) on another page. Finally, when flowchart lines cross, the technician must ensure that the correct path is followed. Crossing lines (figure 5) indicate that the points connect. Lines that cross with a jump symbol in the center (figure 6) indicate that the points do not connect. The technician must correctly follow the arrows to complete the troubleshooting procedure.

Look for the pill shaped beginning symbol in the upper left corner of the procedure. This symbol should contain the identified malfunction or symptom. Starting from this point, follow the arrowed lines through the procedure. Remember that the diamond shaped symbols denote a decision step. At each of these points you will be required to make a decision and to follow the appropriate line for that decision. Continue to follow the arrowed lines through the procedure until the malfunction or symptom is corrected.



Figure 1. Pill Shaped Symbol

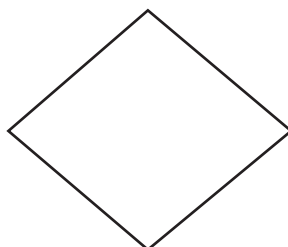

Figure 2. Diamond Shaped Symbol



Figure 3. Rectangle Shaped Symbol



Figure 4. Circular Shaped Symbol

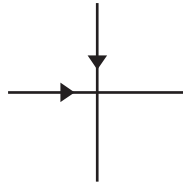

Figure 5. Crossed Lines Are Connected

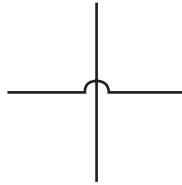

Figure 6. Crossed Lines Are Not Connected

Table 1. Operator Troubleshooting Procedures

Equipment	Malfunction	Work Package, Procedure
ROWPU	ROWPU does not function correctly	WP 0008 00, Procedure 1

Table 2. Unit Troubleshooting Procedures

Equipment	Malfunction	Work Package, Procedure
ROWPU	No fresh water flow during fresh water flush cycle	WP 0009 00, Procedure 3
	No indication of power to the ROWPU	WP 0009 00, Procedure 1
	Product water is too salty	WP 0009 00, Procedure 5
	ROWPU produces low or no quantity of product water	WP 0009 00, Procedure 4
	ROWPU shuts down unexpectedly	WP 0009 00, Procedure 2

END OF WORK PACKAGE

**OPERATOR MAINTENANCE
REVERSE OSMOSIS WATER PURIFICATION UNIT FOR
INLAND AND COASTAL LARGE TUG (LT)
OPERATOR TROUBLESHOOTING PROCEDURES**

INITIAL SETUP:

Personnel Required:

One Watercraft Engineer, 88L

References:

WP 0005 00

WP 0006 00

INTRODUCTION

The work package contains the following operator troubleshooting procedures:

<u>Malfunction/Symptom</u>	<u>Procedure</u>
ROWPU Does Not Function Correctly	1

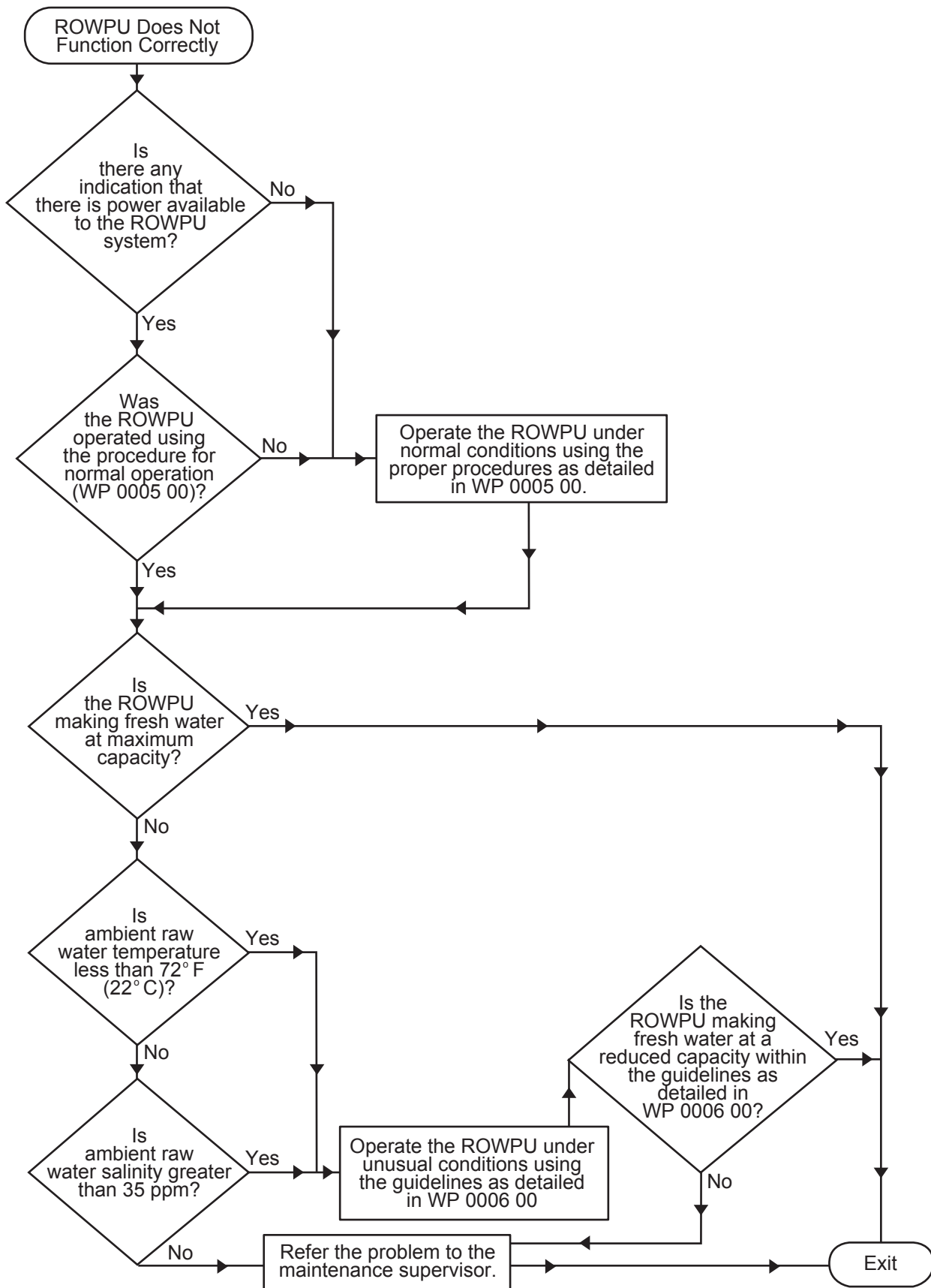

Procedure 1. ROWPU Does Not Function Correctly

END OF WORK PACKAGE

**UNIT MAINTENANCE
REVERSE OSMOSIS WATER PURIFICATION UNIT FOR
INLAND AND COASTAL LARGE TUG (LT)
UNIT TROUBLESHOOTING PROCEDURES**

INITIAL SETUP:

Tools and Special Tools:

Tool Kit, Electrician's (Item 2, Table 2,
WP 0031 00)
Multimeter (Item 3, Table 2, WP 0031 00)

References (continued):

WP 0013 00
WP 0014 00
WP 0016 00
WP 0019 00
WP 0021 00
WP 0022 00
WP 0023 00
WP 0031 00

Personnel Required:

Two Watercraft Engineers, 88L

References:

WP 0005 00
WP 0006 00
WP 0012 00

INTRODUCTION

The work package contains the following unit troubleshooting procedures:

<u>Malfunction/Symptom</u>	<u>Procedure</u>
No Indication of Power to the ROWPU	1
ROWPU Shuts Down Unexpectedly	2
No Fresh Water Flow During Fresh Water Flush Cycle	3
ROWPU Produces Low or No Quantity of Product Water	4
Product Water is too Salty.....	5

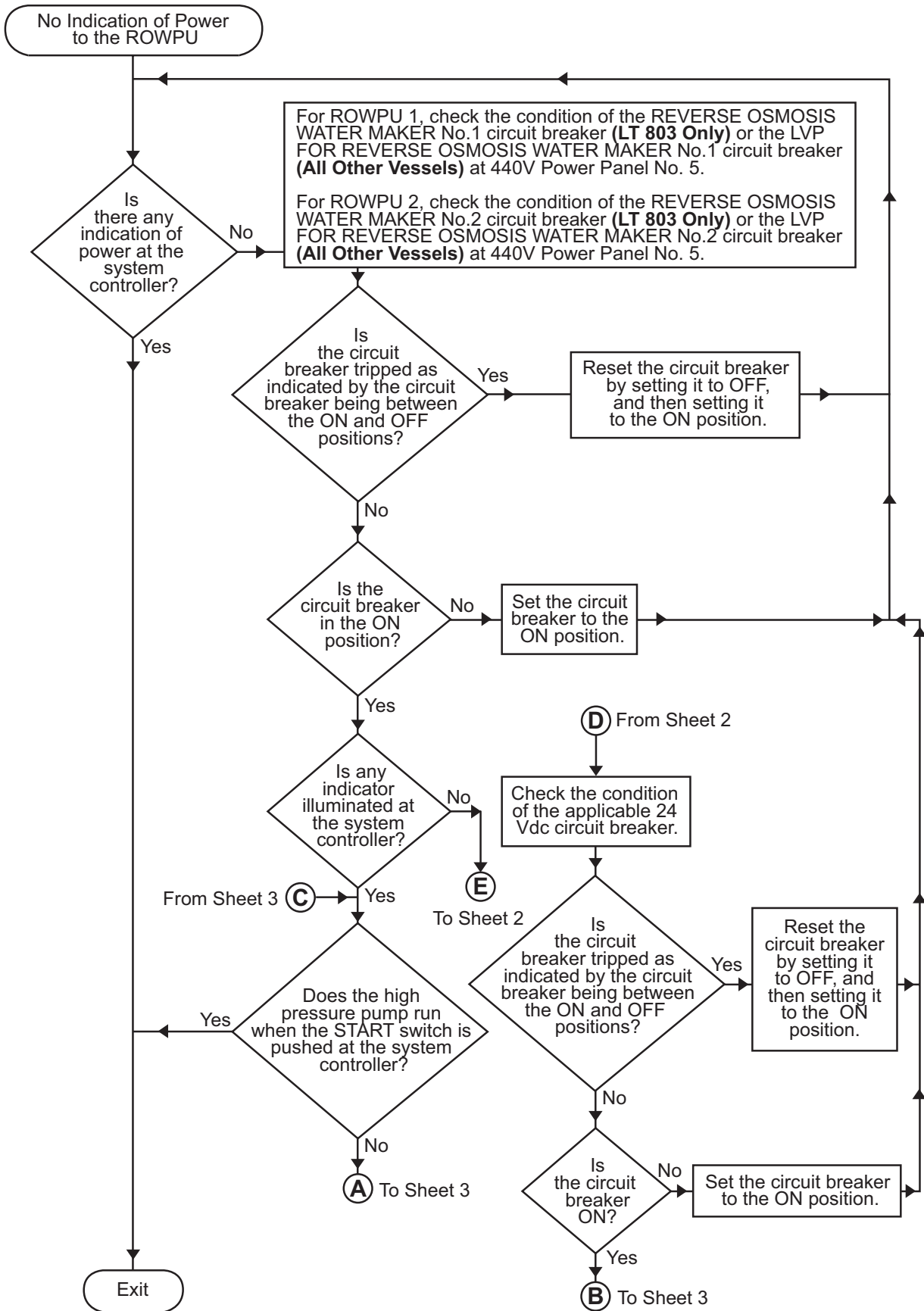

Procedure 1. No Indication of Power to the ROWPU (Sheet 1 of 3)

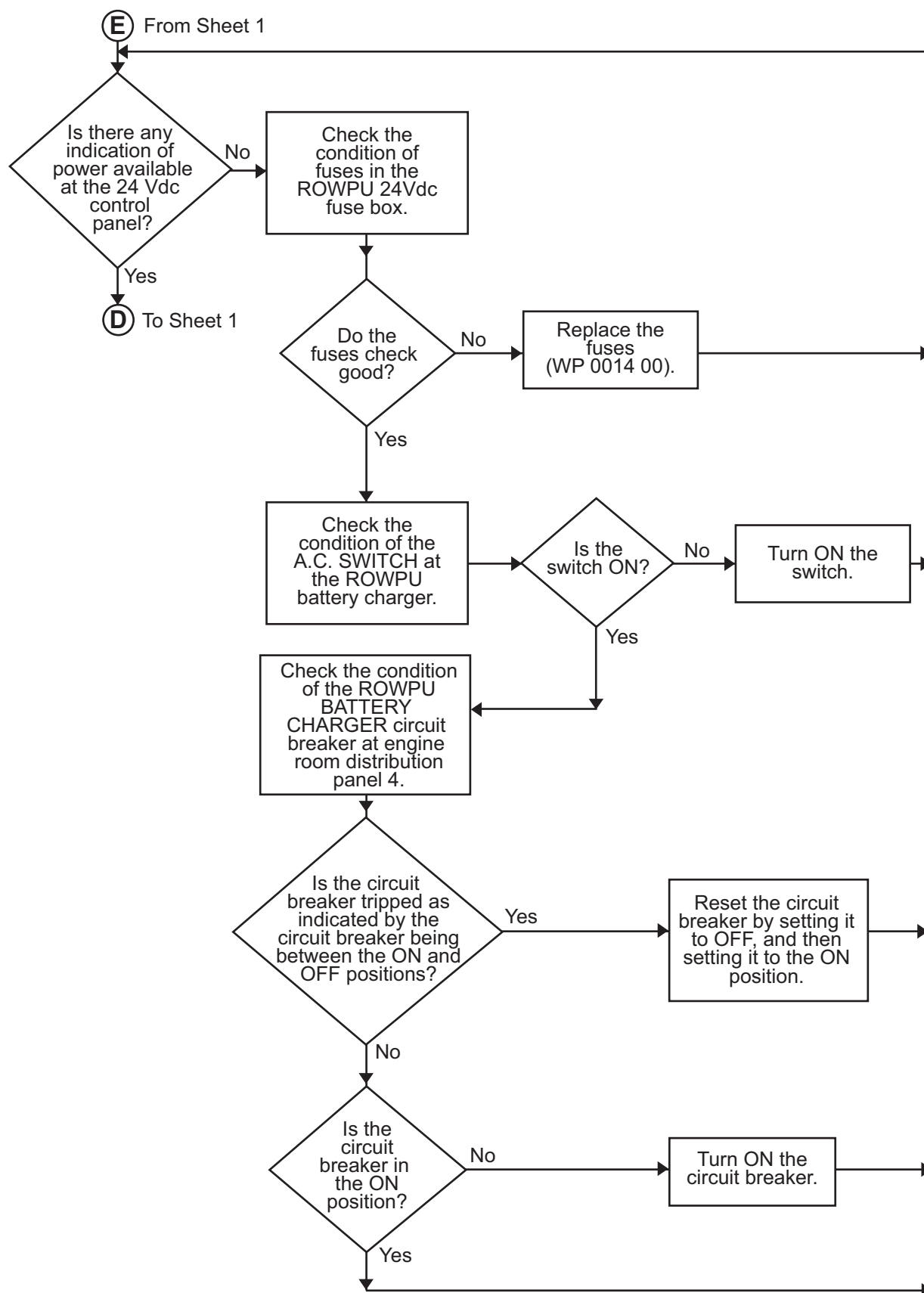

Procedure 1. No Indication of Power to the ROWPU (Sheet 2 of 3)

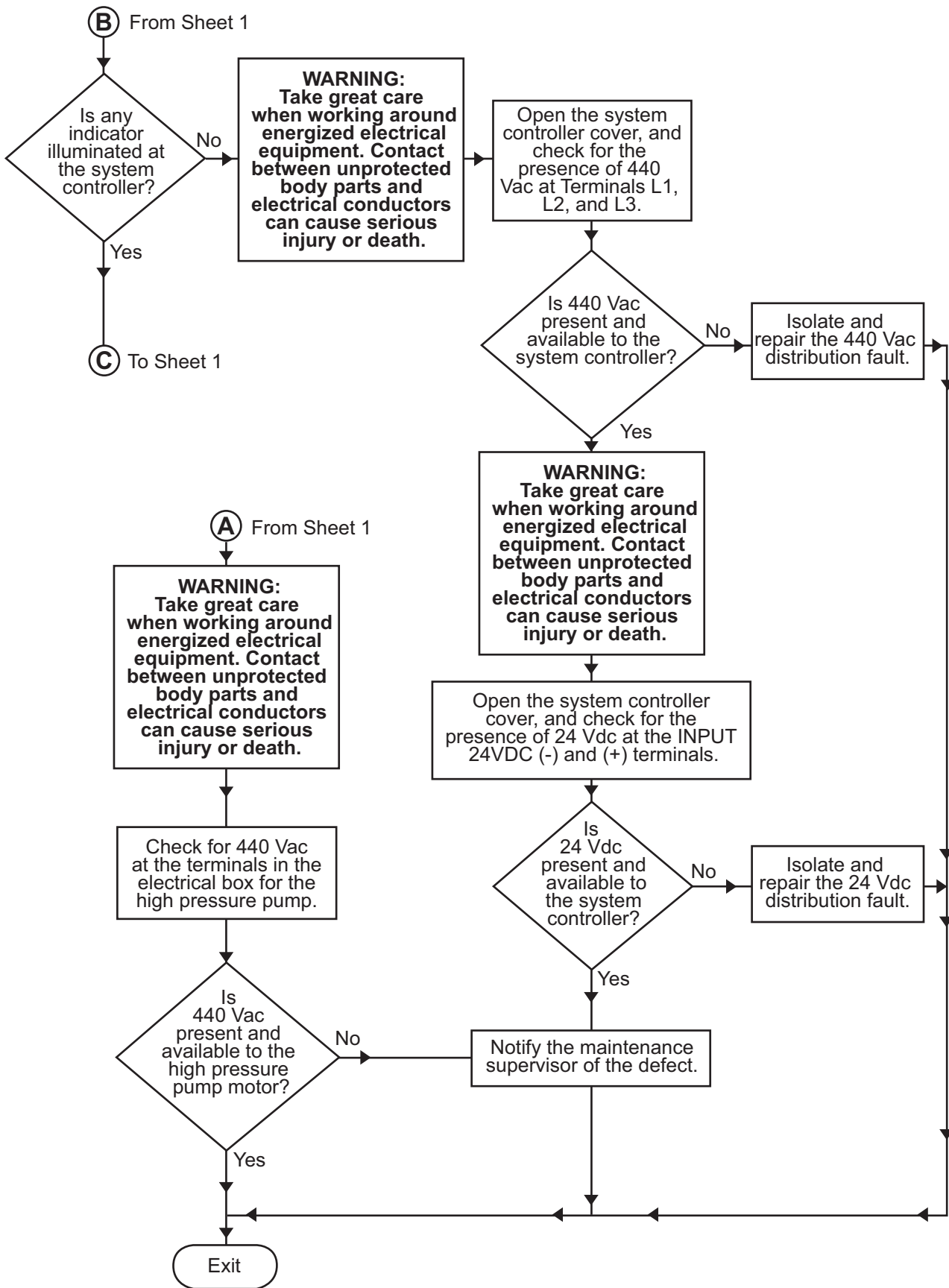

Procedure 1. No Indication of Power to the ROWPU (Sheet 3 of 3)

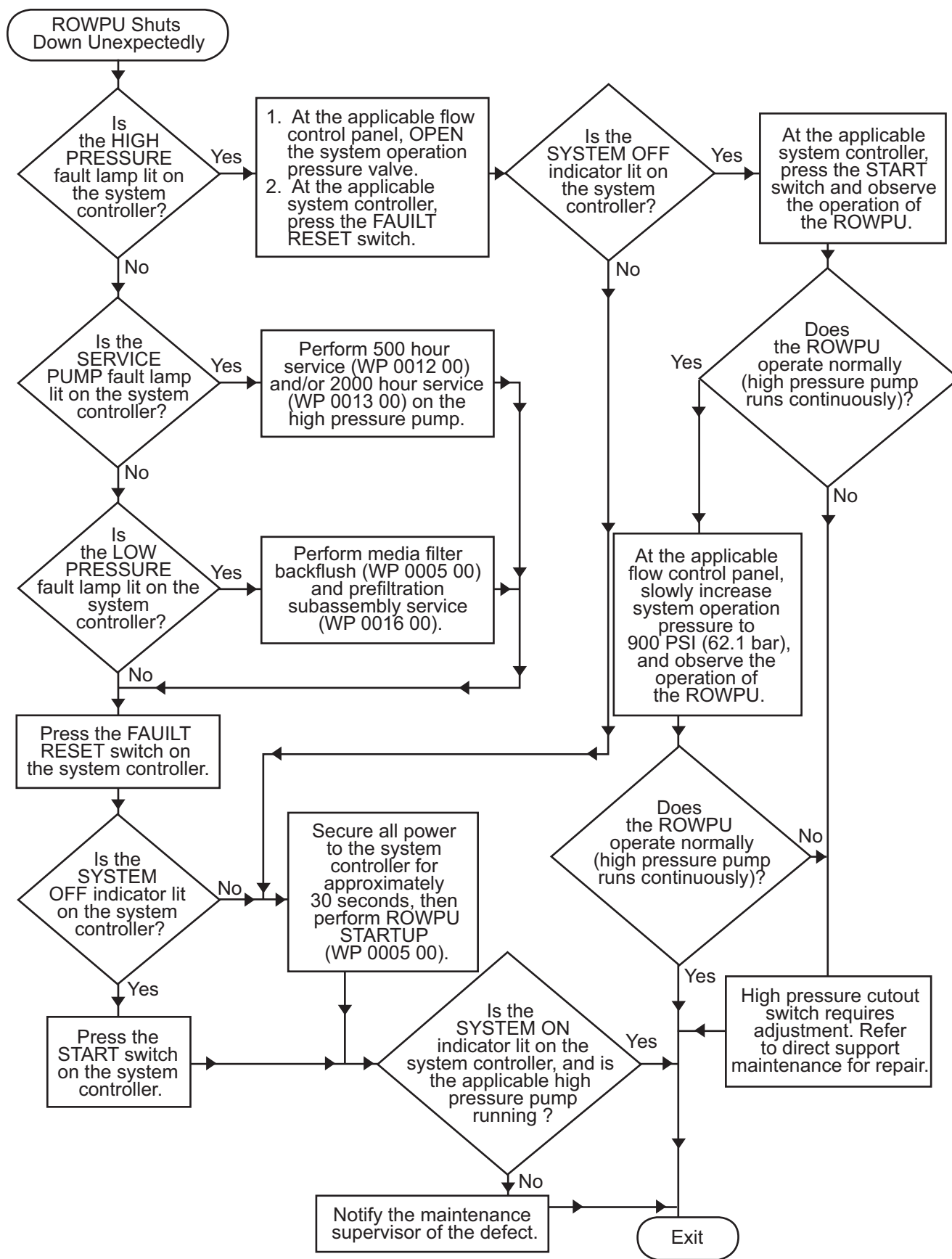

Procedure 2. ROWPU Shuts Down Unexpectedly

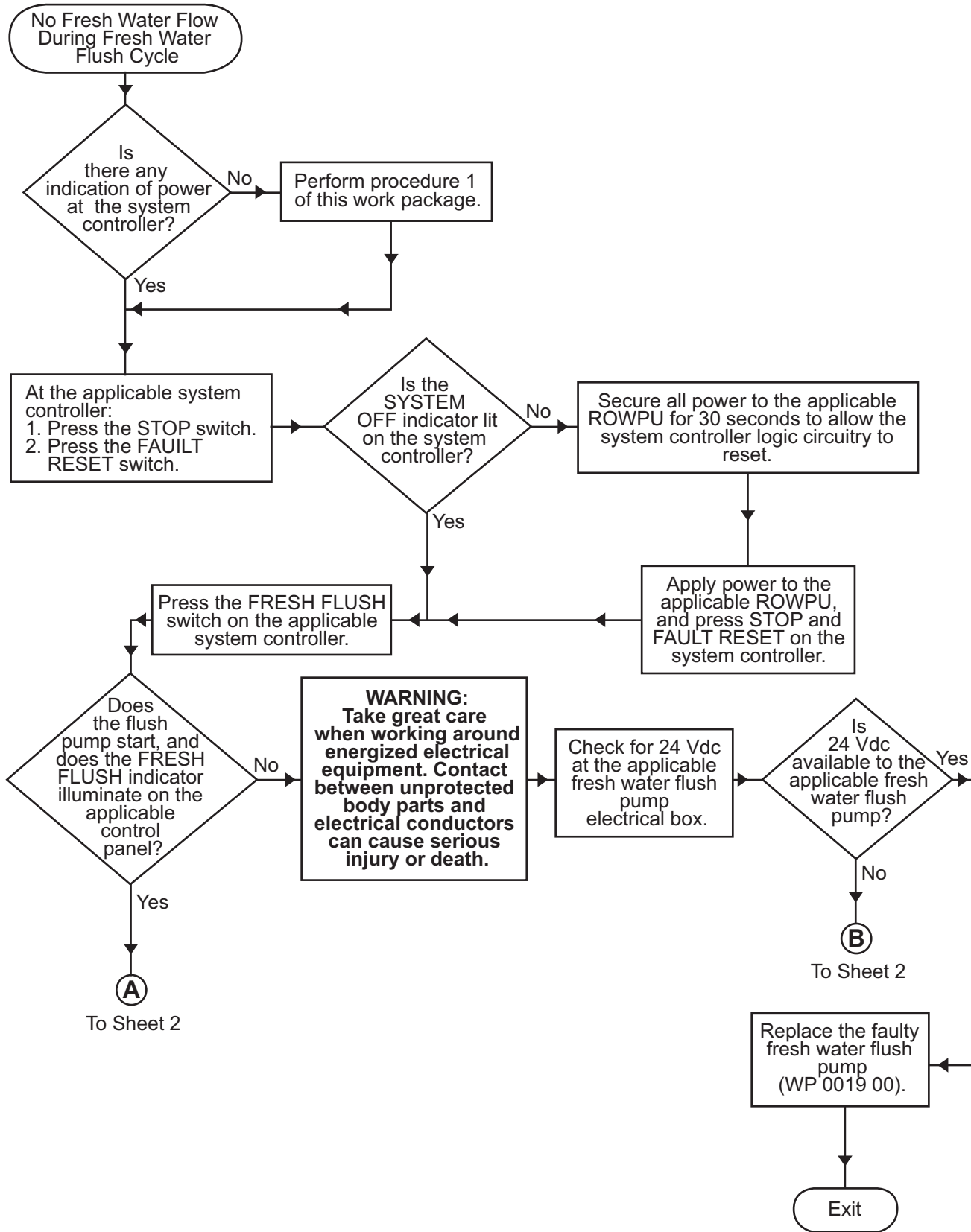

Procedure 3. No Fresh Water Flow During Fresh Water Flush Cycle (Sheet 1 of 2)

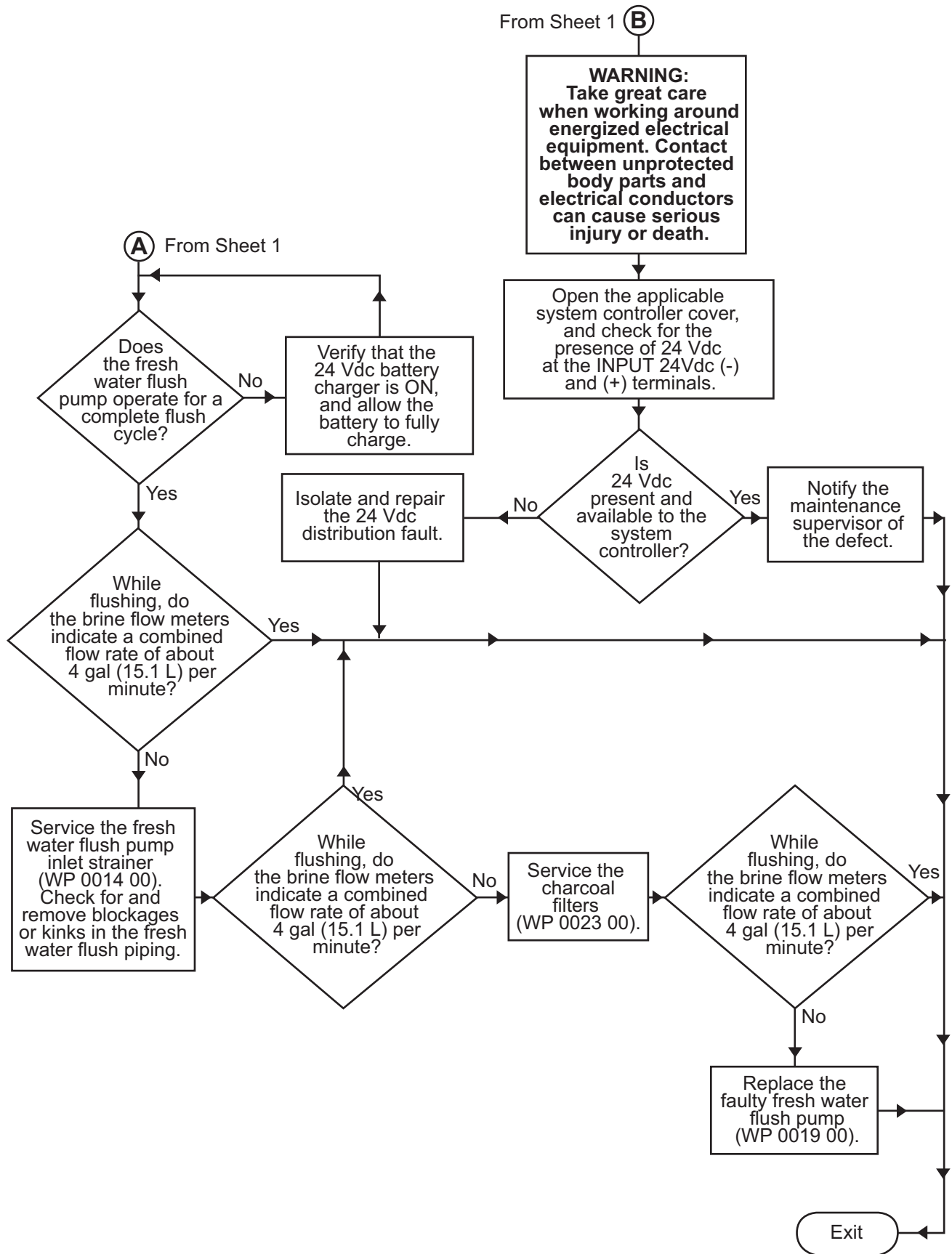

Procedure 3. No Fresh Water Flow During Fresh Water Flush Cycle (Sheet 2 of 2)

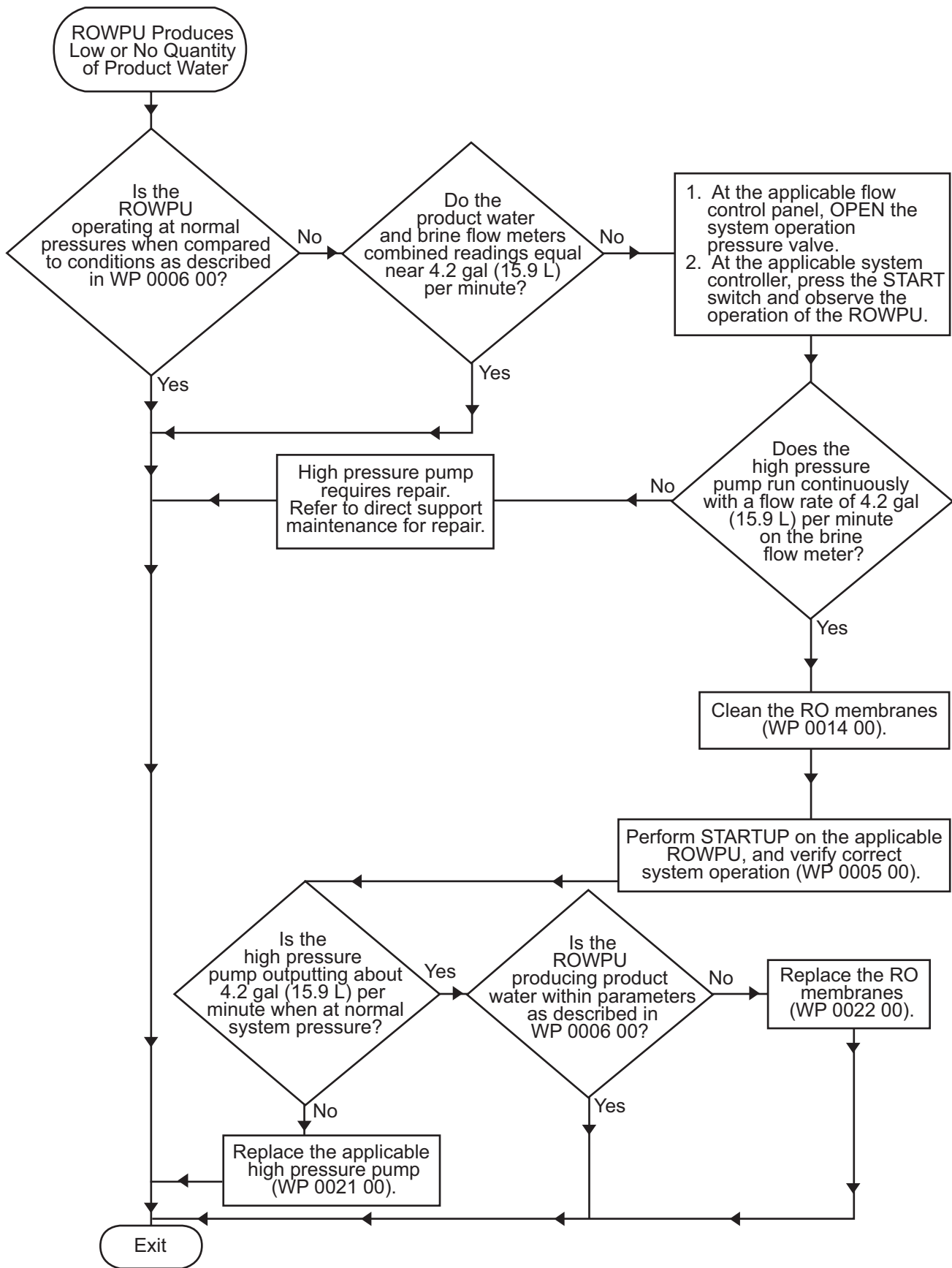

Procedure 4. ROWPU Produces Low or No Quantity of Product Water

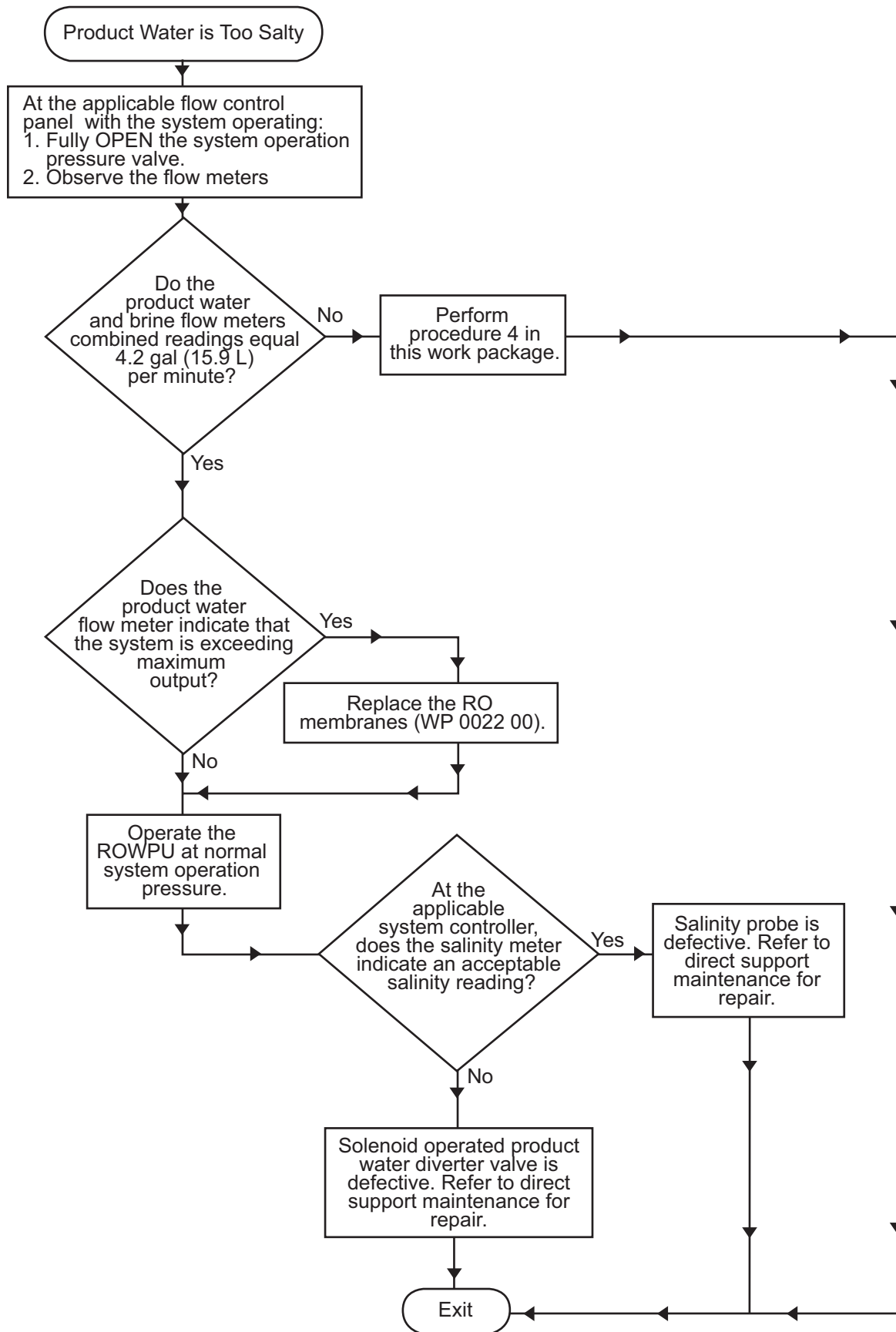

Procedure 5. Product Water is too Salty

END OF WORK PACKAGE

Chapter 4

Maintenance Instructions
for
Reverse Osmosis Water Purification Unit

Inland and Coastal Large Tug (LT)

**OPERATOR AND UNIT MAINTENANCE
REVERSE OSMOSIS WATER PURIFICATION UNIT FOR
INLAND AND COASTAL LARGE TUG (LT)
SERVICE UPON RECEIPT AND PREPARATION FOR STORAGE**

INITIAL SETUP:**Personnel Required:**

One Watercraft Engineer, 88L

References:

TB 740-97-4

WP 0005 00

References (continued):

WP 0012 00

WP 0013 00

WP 0017 00

SERVICE UPON RECEIPT

The Reverse Osmosis Water Purification Units (ROWPU) are factory tested and rinsed with a mild mixture of storage chemical. The chemical allows the system to be stored up to three months without any crew interaction. Prior to use, conduct the Fresh Water Flush (FWF) procedure (WP 0005 00) to remove any chemicals in the product water components and piping.

 **CAUTION**

Operating the high pressure pumps at the incorrect oil level, and without vented oil caps installed, will lead to pump failure.

Upon receipt of the ROWPU, the high pressure pumps must be serviced (WP 0017 00) prior to startup. The high pressure pumps are not shipped with the vented oil caps installed. Operating the high pressure pumps at the incorrect oil level, and without vented oil caps installed, will lead to pump failure.

Upon receipt, the ROWPU should be started, and the readings from the initial startup recorded on the ROWPU system readings log (table 1), and retained for comparison with future readings. The ROWPU systems readings log is provided for the operator's use so that trends in performance of the ROWPU may be documented and compared.

SHELTER REQUIREMENTS

The ROWPU pump motors must be kept dry to prevent damage to the units. The controller units and electrically controlled components are mounted in AMS 2, out of the weather. However, they can still become wet during compartment cleaning, or during service of other systems such as the fire and general service pumps. If there is a possibility that the components or motors could become wet due to cleaning or equipment maintenance operations, cover them with waterproof tarps until cleaning or maintenance is complete.

PRELIMINARY SERVICING OF EQUIPMENT AND PRELIMINARY CHECKS AND ADJUSTMENTS OF EQUIPMENT

Before putting the ROWPU into service, perform all operator (WP 0012 00) and unit (WP 0013 00) PMCS up to, and including, the annual level.

PREPARATION FOR STORAGE

If the ROWPU will be stored longer than three months without use, it must be fresh water flushed (WP 0005 00) and recharged with fresh storage solution every three months. An alternative to using the storage chemical solution is conducting a weekly fresh water flush (WP 0005 00). Failure to conduct weekly fresh water flushes or to recharge the ROWPU storage solution every three months can damage the reverse osmosis membrane elements.

PREPARATION FOR SHIPMENT

The ROWPU is prepared for shipment along with the remainder of the Large Tug (LT). Complete instructions for this preparation are contained in TB 740-97-4, Preservation of Vessels for Storage.

Table 1. ROWPU System Readings Log

ROWPU SYSTEM READINGS LOG

DATE: _____

Reading	System	ROWPU 1	ROWPU 2
Volts		X	X
Hz		X	X
Raw Water Temperature		X	X
Low Pressure Switch Setting		X	X
High Pressure Switch Setting		X	X
Brine Valve Misalignment Switch Setting		X	X
General Service Pressure		X	X
Media Filter Inlet Pressure		X	X
Media Filter Outlet Pressure		X	X
5-Micron Filter Inlet Pressure	X		
High Pressure Pump Inlet Pressure	X		
System Operation Pressure	X		
Product Water Output Pressure	X		
Brine Discharge Pressure	X		
Brine Water Flow Rate	X		
Product Water Flow Rate	X		
Raw Water Salinity (ppm)	X		
Product Water Salinity (ppm)	X		
Salinity Meter Reading at System Controller (ppm)	X		

END OF WORK PACKAGE

**OPERATOR AND UNIT MAINTENANCE
REVERSE OSMOSIS WATER PURIFICATION UNIT FOR
INLAND AND COASTAL LARGE TUG (LT)
PMCS INTRODUCTION**

PURPOSE AND USE OF PREVENTIVE MAINTENANCE CHECKS AND SERVICES (PMCS) DATA

PMCS is performed to keep the reverse osmosis water purification unit in operating condition. The checks are used to find, correct, and report problems so that defects may be discovered and corrected. PMCS is to be accomplished each day the reverse osmosis water purification unit is operated using the appropriate work packages. Pay attention to all WARNINGS, CAUTIONS, and NOTES that precede individual steps. WARNINGS indicate possible danger to personnel. CAUTIONS indicate possible damage to equipment. NOTES are for clarification and additional information. An explanation is prepared for each PMCS check entry, and for any general checks and services common to an entire piece of equipment or system. An explanation of PMCS chart columns follows:

ITEM NUMBER COLUMN

The checks and services are numbered within a specific work package in chronological order.

INTERVAL

This column indicates the periodicity of the check or service.

1. Before Reverse Osmosis Water Purification Unit (ROWPU) operation, do Before PMCS.
2. During reverse osmosis water purification unit operation, do During PMCS.
3. After reverse osmosis water purification unit operation, do After PMCS.
4. Once a week do Weekly PMCS.
5. Do Monthly PMCS once a month. If equipment has not been operated in a month, also do During PMCS at the same time as Monthly PMCS.
6. Do Quarterly PMCS once a quarter. If the equipment has not been operated in a quarter, also do After PMCS at the same time as Quarterly PMCS.
7. Do Semiannual PMCS once every six months. If the equipment has not been operated within the last six months, also do the Monthly PMCS at the same time as Semiannual PMCS.
8. Do Annual PMCS once a year.
9. If a deficiency is noted when performing PMCS, fix it, if possible, using troubleshooting procedures and/or maintenance procedures. If the deficiency cannot be corrected, write up the items not fixed on DA Form 2404 for unit maintenance. For further information on how to use this form, see DA PAM 738-750.

MANHOUR

This column indicates the projected amount of time that is expected to take to complete the check or service. Checks and services that require additional personnel include a cumulative amount of time.

ITEM TO BE CHECKED OR SERVICED

This column lists the equipment or item to be checked or serviced.

PROCEDURE COLUMN

This column contains a brief description of how to perform the checks and services, or it contains the reference to the work package or technical manual that contains the procedural information. Carefully follow the instructions. If the necessary tools are not available, or if the procedure tells you to, have organizational maintenance do the work.

EQUIPMENT NOT READY/AVAILABLE IF

Lists the criteria that will limit the use of equipment, or make it not ready for use. Depending on the severity of the limitation, the reverse osmosis water purification unit may not be able to operate and perform its primary mission. The terms "ready/available" and "mission capable" refer to the same status: Equipment is on hand and can perform its combat mission. If tools required to perform PMCS are not listed in the work package, notify unit maintenance. Write up items not fixed on DA Form 2404 for unit maintenance. For further information on how to use this form, see DA PAM 738-750.

DOCUMENTATION OF PMCS ITEM FAILURES

PMCS item failures are to be recorded on DA Form 2404, Equipment Inspection, and Maintenance Worksheet, and forwarded to Unit Maintenance via the vessel's Chief Engineer. Documentation of PMCS item failures must include the compartment location and item number within the work package to ensure proper dissemination. All corrected faults will be recorded on DA Form 4640 (Harbor Boat Deck Department Log for Class A&B Vessels) and DA Form 4993 (Harbor Boat Engine Department Log for Class A and C-1). All uncorrected faults will be transcribed to a DA Form 2407, Maintenance Request, and the appropriate log entry must be made. The crew will service the LT as outlined by the intervals contained in the PMCS tables.

CORROSION PREVENTION AND CONTROL (CPC)

Corrosion Prevention and Control (CPC) of Army materiel is a continuing concern. It is important that any corrosion problems be reported so that they can be corrected and improvements made to prevent future problems. Corrosion is typically associated with rusting of metals, but it can also include deterioration of other materials, such as rubber and plastic. Unusual cracking, softening, swelling, or breaking of materials may indicate a corrosion problem. Suspected corrosion problems should be reported using SF 368 (Product Quality Deficiency Report). Use of key words such as "corrosion," "rust," "deterioration," or "cracking" will ensure that the information is identified as a CPC problem.

LEAKAGE DEFINITION

CAUTION

Equipment operation is allowable with minor leakages (Class I or II) except for fuel leaks. Of course, consideration must be given to the fluid capacity of the item or system being checked. When in doubt, ask your supervisor.

When operating with Class I or II leaks, continue to check fluid levels as required in your PMCS. Class III leaks should be reported immediately to your supervisor. It is necessary to know how fluid leakage affects the status of the reverse osmosis water purification unit. The following are definitions of the classes of leakage an operator or crewmember needs to know to be able to determine the condition of the leak. Learn and then be familiar with them. When in doubt, ask your supervisor.

LEAKAGE CLASSIFICATIONS I, II, III

Leakage classifications. Leakage definitions for operator/crew PMCS shall be classified as follows:

1. Class I: Seepage of fluid (as indicated by wetness or discoloration) not great enough to form drops.

2. Class II: Leakage of fluid great enough to form drops but not enough to cause drops to drip from the item being checked/inspected.
3. Class III: Leakage of fluid great enough to form drops that fall from the item being checked/inspected.

INSPECTION

Look for signs of a problem or trouble. Senses help here. You can feel, smell, hear, or see many problems. Be alert when on the vessel. Inspect to see if items are in good condition. Are they correctly assembled, stowed, secured, excessively worn, leaking, corroded, or properly lubricated? Correct any problems found or notify unit maintenance. There are some common items to check all over the reverse osmosis water purification unit. These include the following:

1. Bolts, clamps, nuts, and screws: Continuously check for looseness. Look for chipped paint, bare metal, rust, or corrosion around bolt and screw heads and nuts. Tighten them when you find them loose. If tools are not available, notify unit maintenance.
2. Welds: Many items on the reverse osmosis water purification unit are welded. To check these welds, look for chipped paint, rust, corrosion, or gaps. When these conditions exist, notify unit maintenance on DA Form 2404.
3. Electrical wires, connectors, and harnesses: Tighten loose connectors. Look for cracked or broken insulation, bare wires, and broken connectors. If any are found, notify unit maintenance.
4. Hoses and fluid lines: Look for wear, damage, and leaks, and make sure clamps and fittings are tight. Wet spots mean a leak. A stain by a fitting or connector can also mean a leak. When you find a leak, notify unit maintenance.

GENERAL STATEMENT OF LUBRICATION REQUIREMENTS

Any lubricants called out by PMCS in this manual are identified by standard military symbols (MIL-HDBK-113 and MIL-HDBK-275).

LUBRICATION SERVICE INTERVALS - NORMAL CONDITIONS

For safer, more trouble free operations, make sure that your reverse osmosis water purification unit is serviced when it needs it. For the proper lubrication and service intervals, see WP 0012 00 and WP 0013 00.

LUBRICATION SERVICE INTERVALS - UNUSUAL CONDITIONS

The reverse osmosis water purification unit may require extra service and care when it is operated under unusual conditions. High or low temperatures, long periods of hard use, or continued use in a dirty environment will break down the lubricants and fluids, requiring more frequent service.

LUBRICATION UNIVERSALS

1. Always clean fittings before lubricating them. Failure to do so can force contaminants into the bearing.
2. Always use the PMCS work packages as the guide for lubrication.
3. Never use the wrong type/grade of lubricant.
4. Never use too much lubricant.

END OF WORK PACKAGE

**OPERATOR MAINTENANCE
REVERSE OSMOSIS WATER PURIFICATION UNIT FOR
INLAND AND COASTAL LARGE TUG (LT)
OPERATOR PREVENTIVE MAINTENANCE CHECKS AND SERVICES (PMCS) INCLUDING LUBRICATION**

ITEM NO.	INTERVAL	MAN-HOUR	ITEM TO BE CHECKED OR SERVICED	PROCEDURE	EQUIPMENT NOT READY/ AVAILABLE IF:
1	Before	0.5	Media Filter	Backflush and rinse media as required to prevent differential pressure from exceeding 20 PSI (1.4 bar) (WP 0005 00).	
2	Before	0.2	5-Micron Filter	Verify that the filter housing is clean, and replace the filter element if the pressure differential across the filter is greater than 10 PSI (0.7 bar) (WP 0016 00).	
3	Before	0.2	20-Micron Filter	Verify that the filter housing is clean, and replace the filter element if the pressure differential across the filter is greater than 10 PSI (0.7 bar) (WP 0016 00).	
4	During	0.5	Media Filter	Backflush and rinse media as required to prevent differential pressure from exceeding 20 PSI (1.4 bar) (WP 0005 00).	
5	During	2.0	Reverse Osmosis (RO) Membranes	Clean RO membrane elements when production of product water decreases by 10% or when salinity meter readings indicate product water produced contains more than 300 ppm salt (WP 0014 00).	

ITEM NO.	INTERVAL	MAN-HOUR	ITEM TO BE CHECKED OR SERVICED	PROCEDURE	EQUIPMENT NOT READY/ AVAILABLE IF:
6	During	0.2	ROWPU Gauges	<p>Check the following gauges for damage and proper operation.</p> <p>a. At each flow control panel:</p> <ul style="list-style-type: none"> (1) BRINE DISCHARGE PRESSURE (2) HIGH PRESSURE PUMP INLET PRESSURE (3) SYSTEM OPERATION PRESSURE (4) PRODUCT flow meter (5) BRINE flow meter (6) PRODUCT WATER OUTPUT PRESSURE <div data-bbox="740 751 1200 1199" data-label="Diagram"> </div> <p>b. The inlet pressure gauge at each 5-micron filter.</p> <div data-bbox="537 1373 1325 1864" data-label="Diagram"> </div>	Gauges fail to operate. Class III leaks.

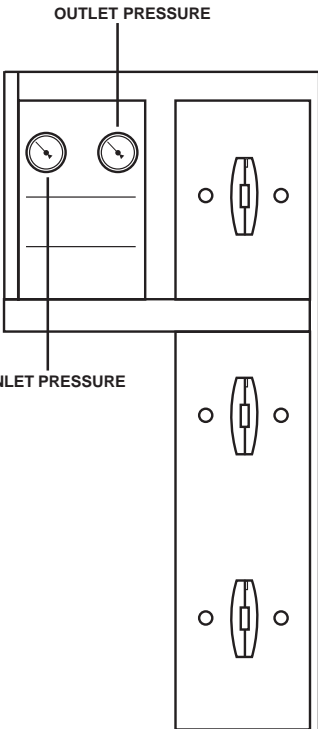
ITEM NO.	INTERVAL	MAN-HOUR	ITEM TO BE CHECKED OR SERVICED	PROCEDURE	EQUIPMENT NOT READY/ AVAILABLE IF:
				<p>c. The following media filter gauges: (1) INLET PRESSURE (2) OUTLET PRESSURE</p> 	
7	After	0.5	Media Filter	<p>Backflush and rinse media as required to prevent differential pressure from exceeding 20 PSI (1.4 bar) (WP 0005 00).</p>	
8	Weekly	0.5	Media Filter	<p>Backflush and rinse media as required to prevent differential pressure from exceeding 20 PSI (1.4 bar) (WP 0005 00).</p>	
9	Monthly	0.2	5-Micron Filter	<p>Verify that the filter housing is clean, and replace the filter element if the pressure differential across the filter is greater than 10 PSI (0.7 bar) (WP 0016 00).</p>	
10	Monthly	0.2	20-Micron Filter	<p>Verify that the filter housing is clean, and replace the filter element if the pressure differential across the filter is greater than 10 PSI (0.7 bar) (WP 0016 00).</p>	

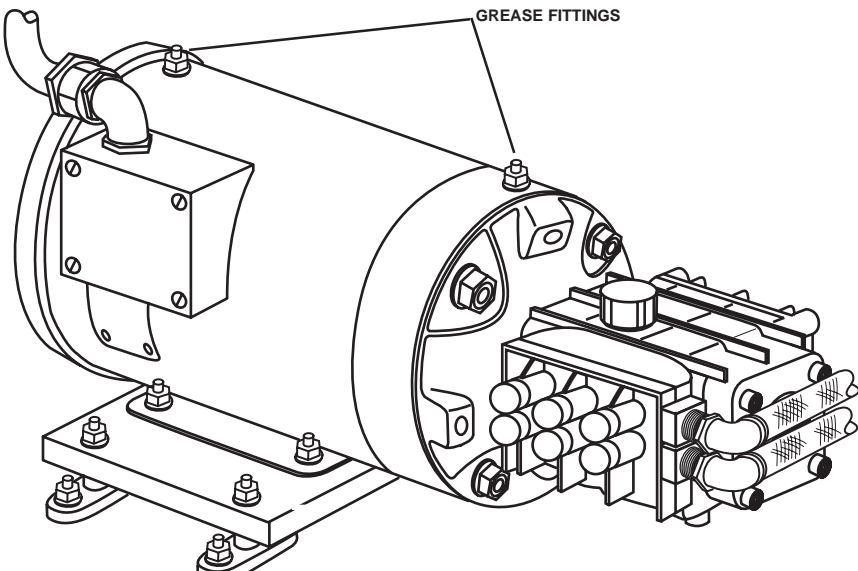
ITEM NO.	INTERVAL	MAN-HOUR	ITEM TO BE CHECKED OR SERVICED	PROCEDURE	EQUIPMENT NOT READY/ AVAILABLE IF:
11	Quarterly	2.0	Reverse Osmosis (RO) Membranes	Clean RO membrane elements when production of product water decreases by 10% or when salinity meter readings indicate product water produced contains more than 300 ppm salt (WP 0014 00).	
12	Semi-annually	0.2	High Pressure Pump Electric Motors	<p style="text-align: center;">⚠ CAUTION</p> <p>Use only polyurea base grease in the high pressure pump motors. The use of lithium or silicone base grease will damage the high pressure pumps.</p> <p>Apply three pumps of polyurea base grease to each grease fitting on the high pressure pump motors.</p>	
					
13	500 Hours	1.0	High Pressure Pump	Change high pressure pump oil every 500 hours of operation (WP 0017 00).	

END OF WORK PACKAGE

**UNIT MAINTENANCE
REVERSE OSMOSIS WATER PURIFICATION UNIT FOR
INLAND AND COASTAL LARGE TUG (LT)
UNIT PREVENTIVE MAINTENANCE CHECKS AND SERVICES (PMCS) INCLUDING LUBRICATION**

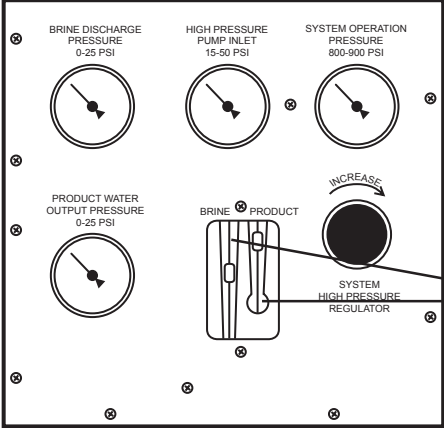
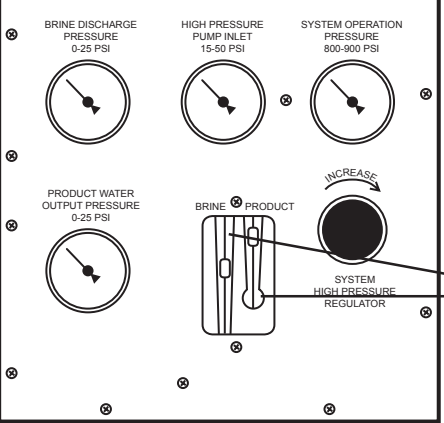
ITEM NO.	INTERVAL	MAN-HOUR	ITEM TO BE CHECKED OR SERVICED	PROCEDURE	EQUIPMENT NOT READY/ AVAILABLE IF:
1	Before	0.1	Flow Control Panels	<p>Inspect flow meters for contamination, obstructions, and biological growth. Refer the unit to direct support maintenance if the flow meters require cleaning.</p> 	Any obstructed or contaminated flow meter.
2	During	0.5	Charcoal Filter	Service the charcoal filter quarterly, or when fresh flushing water emits a sulfur-like smell (WP 0023 00).	
3	Weekly	0.1	Flow Control Panels	<p>Inspect flow meters for contamination, obstructions, and biological growth. Refer the unit to direct support maintenance if the flow meters require cleaning.</p> 	Any obstructed or contaminated flow meter.

ITEM NO.	INTERVAL	MAN-HOUR	ITEM TO BE CHECKED OR SERVICED	PROCEDURE	EQUIPMENT NOT READY/ AVAILABLE IF:
4	Quarterly	0.5	Charcoal Filter	Service the charcoal filter quarterly, or when fresh flushing water emits a sulfur-like smell (WP 0023 00).	
5	Annual	2.0	Salinity Probe	Refer the unit to direct support maintenance to clean the salinity probes.	
6	2000 Operating Hours	4.0	High Pressure Pump	Refer the unit to direct support maintenance for replacement of the high pressure pump seals and valves, and plunger oil seals every 2000 hours of operation.	

END OF WORK PACKAGE

Chapter 5

**Operator Maintenance Instructions
for
Reverse Osmosis Water Purification Unit
Inland and Coastal Large Tug (LT)**

**OPERATOR MAINTENANCE
REVERSE OSMOSIS WATER PURIFICATION UNIT FOR
INLAND AND COASTAL LARGE TUG (LT)
REVERSE OSMOSIS WATER PURIFICATION UNIT, SERVICE**

INITIAL SETUP:**Tools and Special Tools:**

Tool Kit, General Mechanic's (Item 1, Table 2, WP 0031 00)
Lubricating Gun, Hand (Item 5, Table 2, WP 0031 00)
Suitable Cleaning Hoses
Suitable 5-Gallon Bucket

Materials/Parts:

Cleaner, Acid (Item 1, Table 1, WP 0035 00)
Cleaner, Alkaline (Item 2, Table 1, WP 0035 00)
Gloves, Chemical and Oil Protective (Item 3, Table 3, WP 0034 00)
Goggles, Industrial (Item 4, Table 3, WP 0034 00)
Grease, Polyurea (Item 6, Table 1, WP 0035 00)
Rag, Wiping (Item 14, Table 1, WP 0035 00)

Materials/Parts (continued):

Tag, Danger (Item 17, Table 1, WP 0035 00)
Tape, Antiseizing (Item 18, Table 1, WP 0035 00)

Personnel Required:

Two Watercraft Engineers, 88L

References:

FM 55-502
TM 55-1925-273-10
WP 0005 00
WP 0016 00
WP 0031 00
WP 0034 00
WP 0035 00

Equipment Conditions:

General service system operating in normal mode
(TM 55-1925-273-10)

SERVICE FRESH WATER FLUSH PUMP INLET STRAINER**DISASSEMBLY**

1. Set to OFF, lock out, and tag out (FM 55-502) the FWF PUMP circuit breaker (figure 1, item 1).
2. CLOSE, lock out, and tag out (FM 55-502) valves RO-V-6 (figure 2, item 1) and RO-V-9 (figure 3, item 1).
3. Unscrew the strainer cover (figure 4, item 1), and remove it from the strainer assembly (figure 4, item 2).
4. Carefully remove the mesh screen (figure 4, item 3) from the strainer assembly (figure 4, item 2).
5. Clean the mesh screen (figure 4, item 3) with fresh water and rags. Remove all debris and foreign matter from the mesh screen.

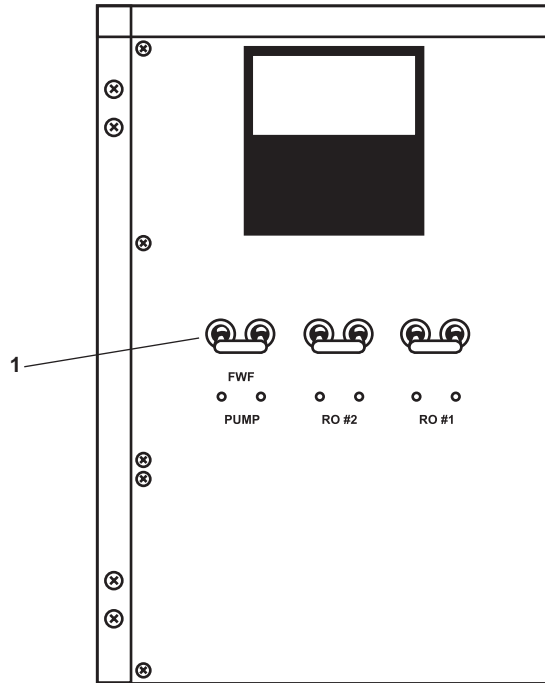

Figure 1. 24 Vdc Control Panel

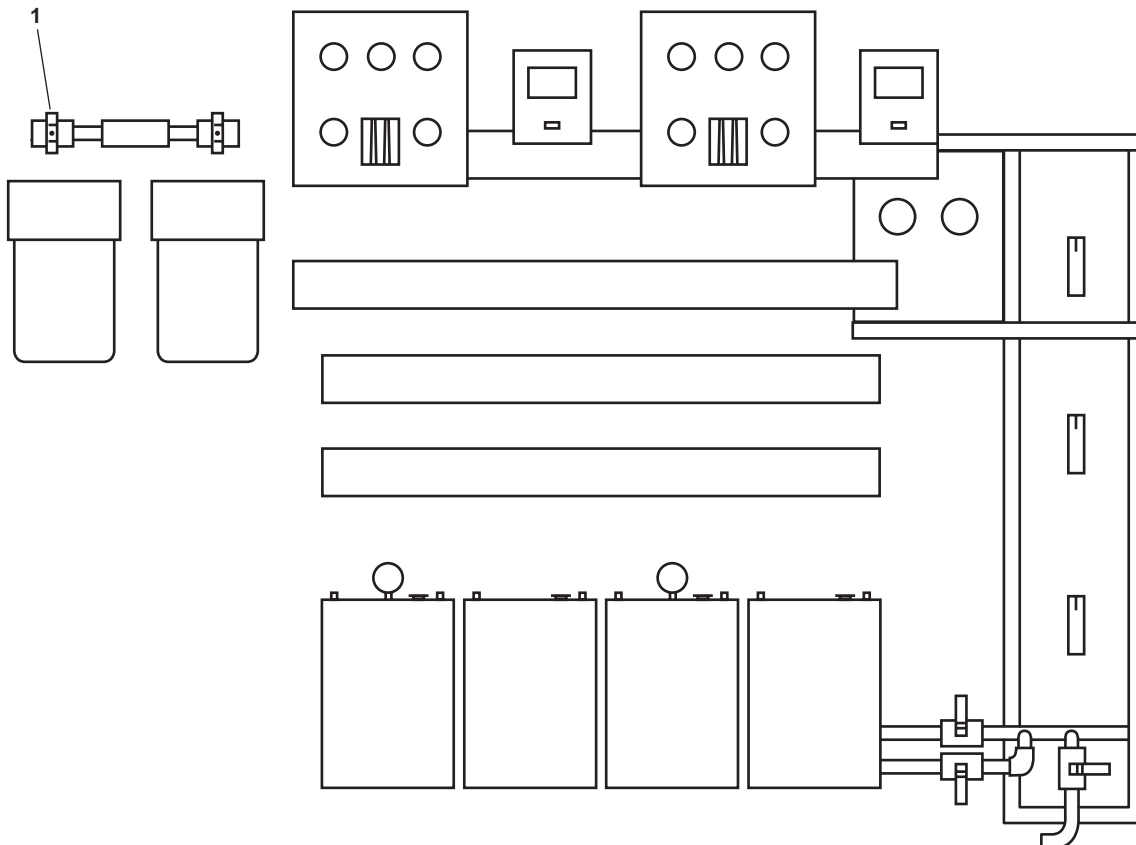

Figure 2. ROWPU System Front View

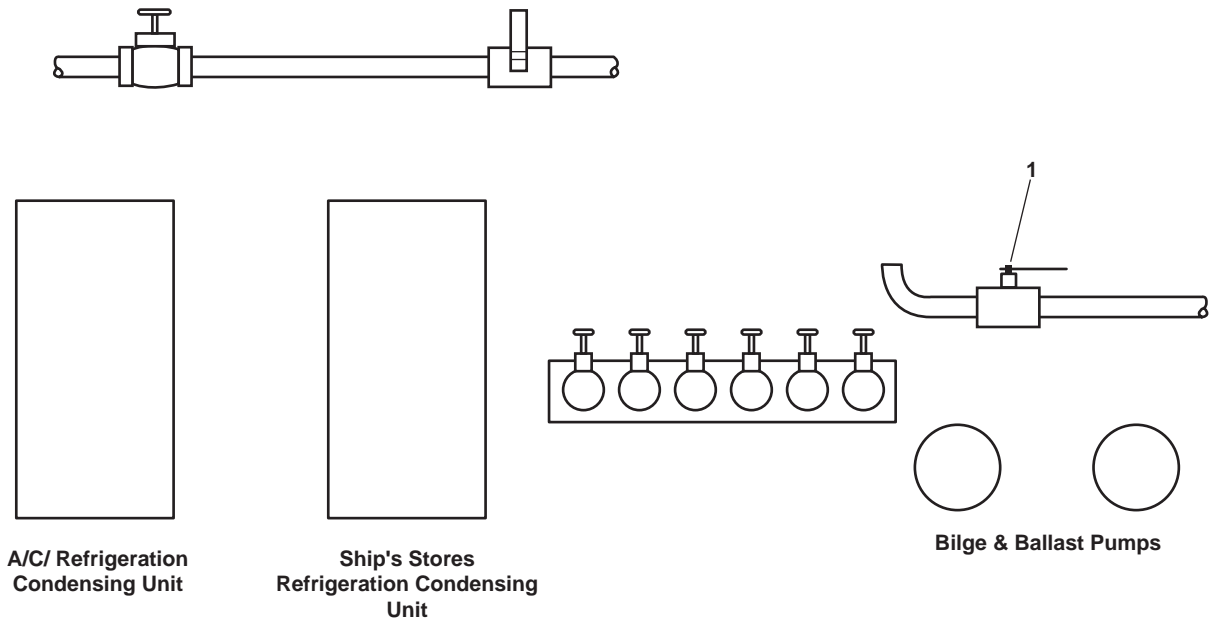

Figure 3. Potable Water Valves on AMS 2 Aft Bulkhead

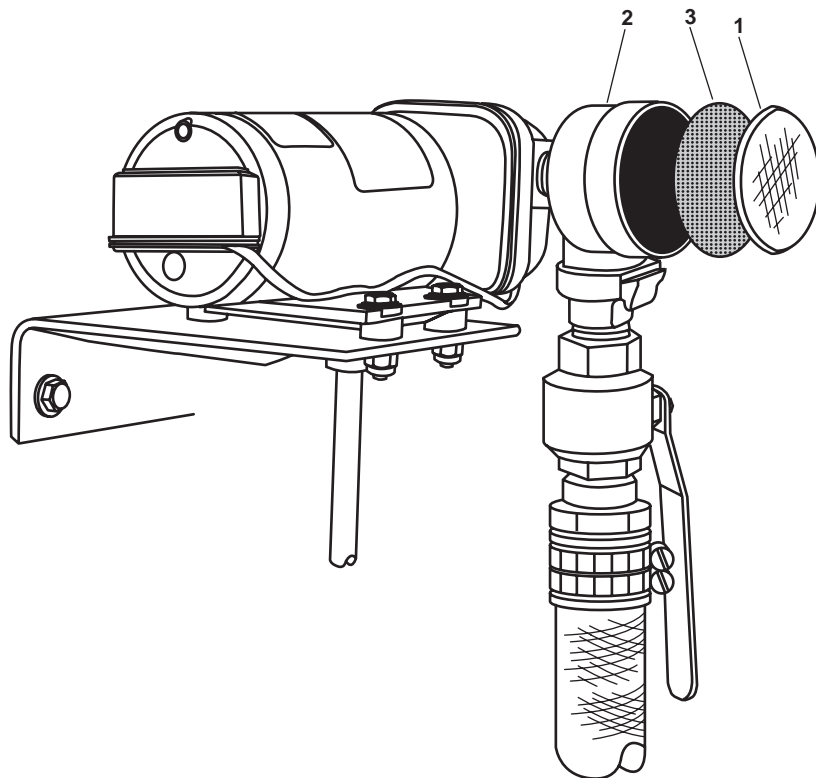

Figure 4. Fresh Water Flush Pump Inlet Strainer

ASSEMBLY

1. Install the mesh screen (figure 4, item 3) in the strainer assembly (figure 4, item 2).
2. Install the strainer cover (figure 4, item 1).
3. Remove the lockouts and tagouts (FM 55-502), and return the equipment to the desired readiness condition.
4. Perform the Fresh Water Flush procedure (WP 0005 00) to verify operation of the fresh water flush pump.
5. Check the fresh water flush pump for leaks.

LUBE HIGH PRESSURE PUMP MOTORS**⚠ CAUTION**

Use only polyurea base grease in the high pressure pump motors. The use of lithium or silicone base grease could damage the high pressure pumps.

1. With a lubricating gun, apply three pumps of polyurea base grease to each grease fitting (figure 5, item 1) on the high pressure pump motors.
2. Remove excess grease from each grease fitting (figure 5, item 1) with a clean wiping rag.

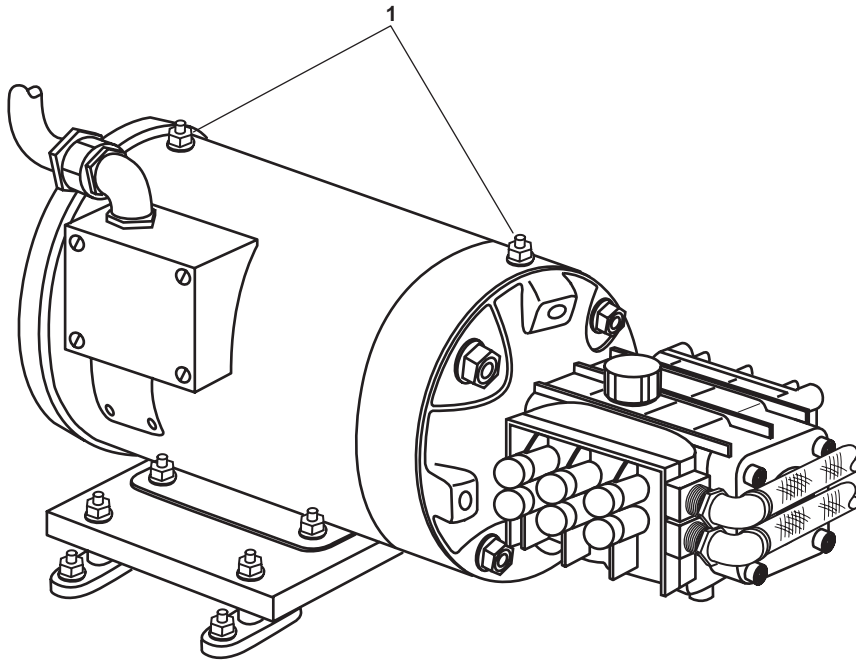

Figure 5. High Pressure Pump Grease Fittings

CLEAN RO MEMBRANES

1. Perform Fresh Water Flush (WP 0005 00).

NOTE

During solution cleaning, the media filter must remain isolated from the circulated cleaning solution.

2. CLOSE, lock out, and tag out (FM 55-502) valves RO-V-3 (figure 6, item 1) and RO-V-4 (figure 6, item 2).

NOTE

The circulated water used to chemically clean the reverse osmosis membranes must be salt and chlorine free. Upon completion of prefiltration subassembly service, verify that the water remaining in the system is salt free and chlorine free. Test samples may be drawn from the 5-micron filter air release valves. Continue performing fresh water flush cycles until the sampled water tests free of salt and chlorine.

3. Perform Prefiltration Subassembly Service (WP 0016 00) on both Reverse Osmosis Water Purification Units (ROWPU).
4. Draw water samples from the 5-micron filter air release valves (figure 7, item 1) and verify that the water is salt and chlorine free. If the samples are salt and chlorine free, continue with the procedure. If the samples are not salt and chlorine free, continue fresh water flushing.

WARNING

Do not allow hydraulic fluid, engine oil, or cleaning solvents to come in contact with unprotected skin or eyes. Prolonged skin contact can cause illness or injury. Eye contact can cause serious injury. Always wear chemical protective gloves and goggles when handling hydraulic fluid, engine oil, and cleaning solvents. Failure to follow these precautions can result in illness or serious injury.

Cleaning solvent is flammable and its vapor is potentially explosive. Do not use cleaning solvent in the vicinity of spark, open flame, or excessive heat. Do not use cleaning solvent in unventilated spaces. Failure to follow these precautions can result in death or serious injury.

NOTE

There are two types of membrane cleaner; alkali and acid. Alkali is most effective on biofouling, and is generally used first. Acid is effective on mineral fouling (e.g. calcium), but is generally only used if the alkali fails to restore product water flow rates.

5. Fill a clean bucket with about two gallons of fresh water, and add the full contents of the cleaning solution packet.
6. Mix and thoroughly dissolve the cleaning solution in the bucket.

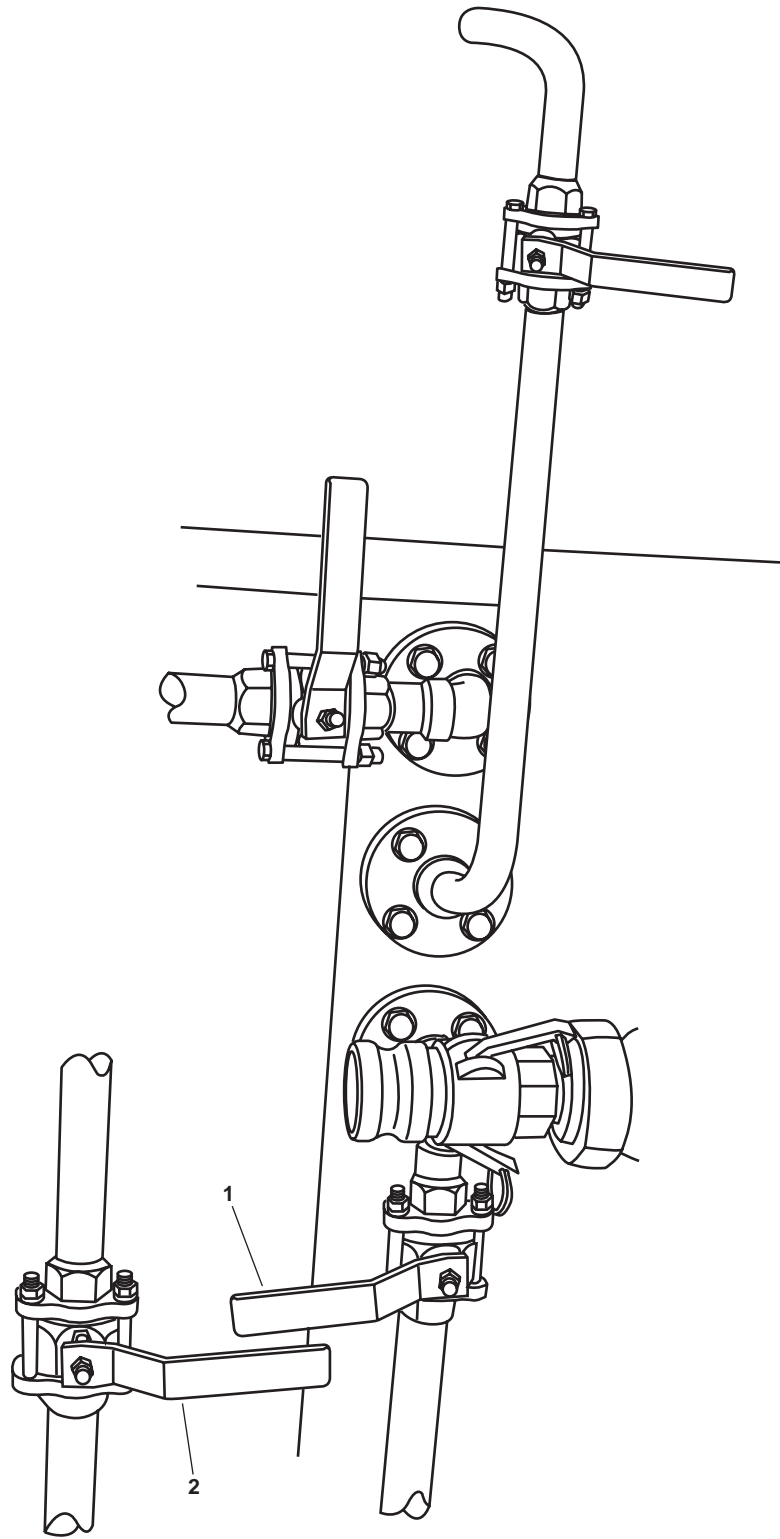

Figure 6. Media Filter Valves

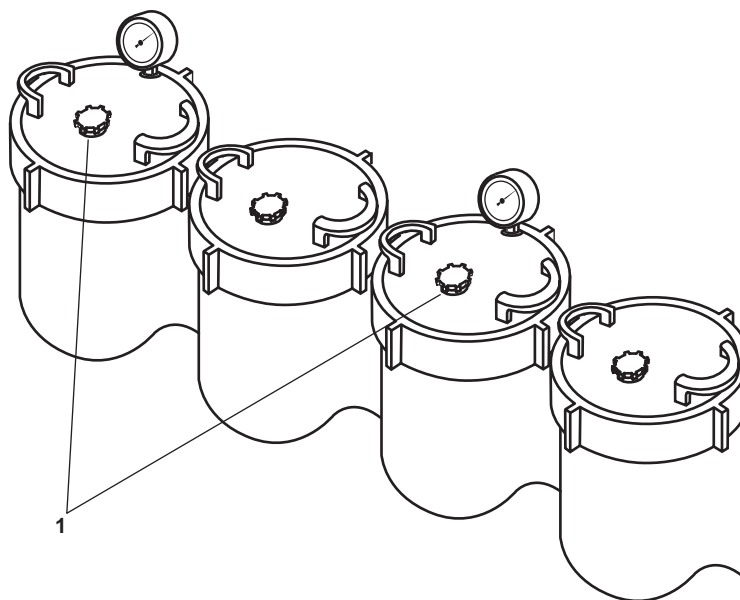

Figure 7. ROWPU Filters

7. Remove the two plugs (figure 8, items 1 and 2) located upstream of valves RO-V-1-2 (figure 8, item 3) and RO-V-2-2 (figure 8, item 4), and attach an 8-foot (2.4 meter) cleaning hose to each exposed connection.
8. Connect the third 8-foot (2.4 meter) cleaning hose to the cleaning supply inlet (figure 9, item 1).
9. Place the opposite ends of the three cleaning hoses in the bucket with the prepared cleaning solution.

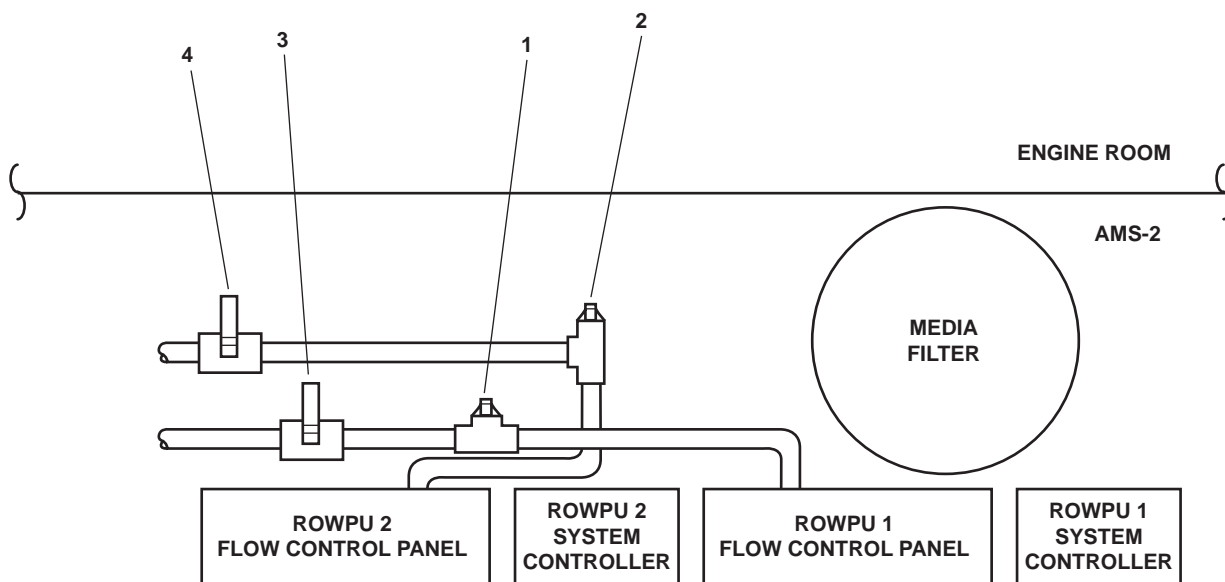

Figure 8. Cleaning Solution Valves and Fittings

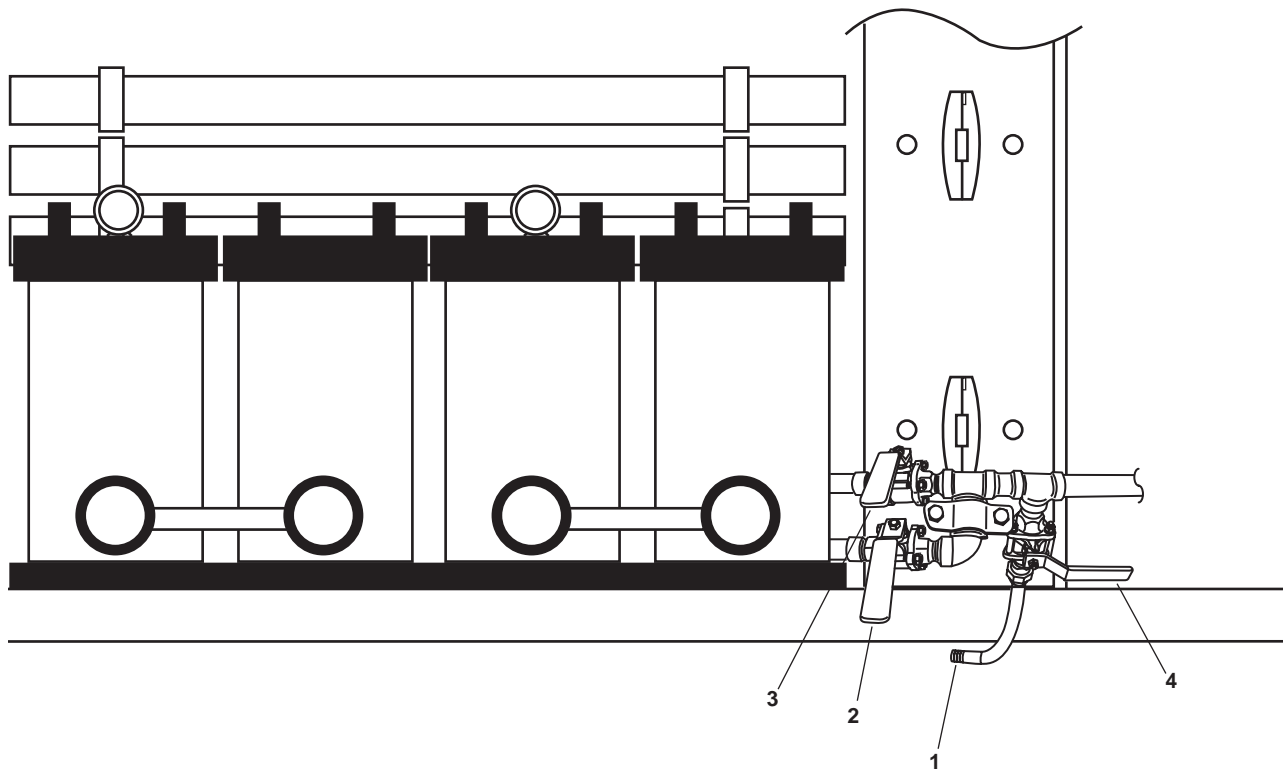

Figure 9. ROWPU Filter Inlet Valves

10. OPEN valves RO-V-1-1 (figure 9, item 2), RO-V-2-1 (figure 9, item 3), and RO-V-5 (figure 9, item 4).
11. CLOSE valves RO-V-1-2 (figure 8, item 3) and RO-V-2-2 (figure 8, item 4).
12. At both flow control panels, verify that the SYSTEM HIGH PRESSURE REGULATOR valves (figure 10, item 1) are OPEN in the fully counterclockwise position.
13. At both system controllers, press the START switches (figure 11, item 1).
14. Verify that the SYSTEM ON indicators (figure 11, item 2) illuminate, and that both high pressure pumps start.
15. At both flow control panels, verify that the BRINE flow meters (figure 10, item 2) indicate flow rates of about 4 gallons (15 liters) per minute.
16. Allow the ROWPUs to recycle the cleaning solution for sixty minutes.
17. At both system controllers, press STOP (figure 11, item 3).
18. Verify that the high pressure pumps stop.
19. Disconnect all cleaning supply hoses from the ROWPU system piping.
20. Place antiseizing tape on the male pipe threads of the two plugs (figure 8, item 1 and 2), and install the plugs in the cleaning supply piping.

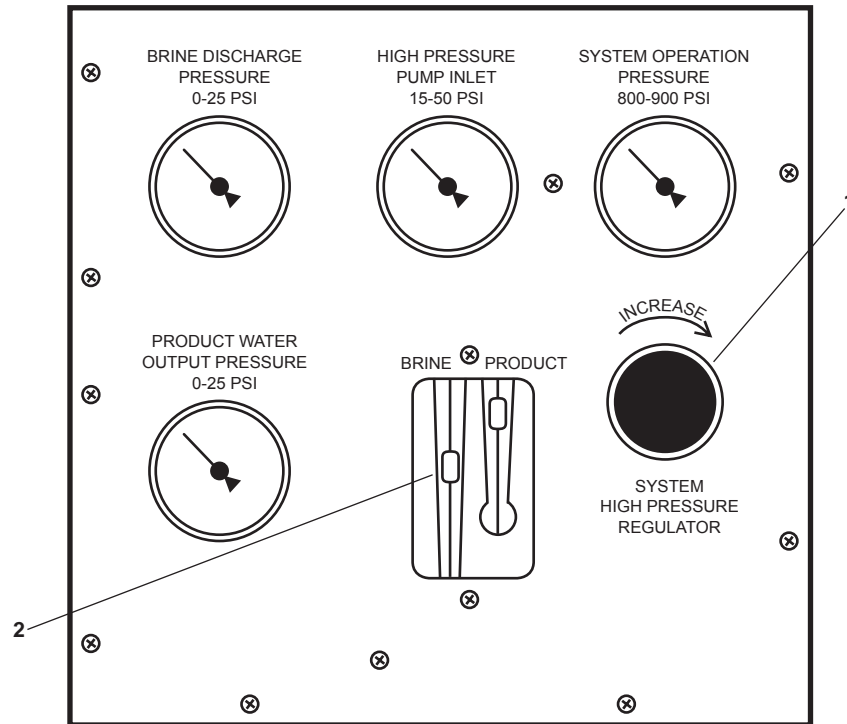

Figure 10. Flow Control Panel

21. CLOSE valves RO-V-1-1 (figure 9, item 2), RO-V-2-1 (figure 9, item 3) and RO-V-5 (figure 9, item 4).
22. OPEN valves RO-V-1-2 (figure 8, item 3), and RO-V-2-2 (figure 8, item 4).
23. Remove the lockouts and tagouts (FM 55-502).
24. Conduct two fresh water flush cycles (WP 0005 00).
25. Perform ROWPU startup (WP 0005 00), and verify product water output is within acceptable standards.
26. Return the equipment to the desired readiness condition (WP 0005 00).

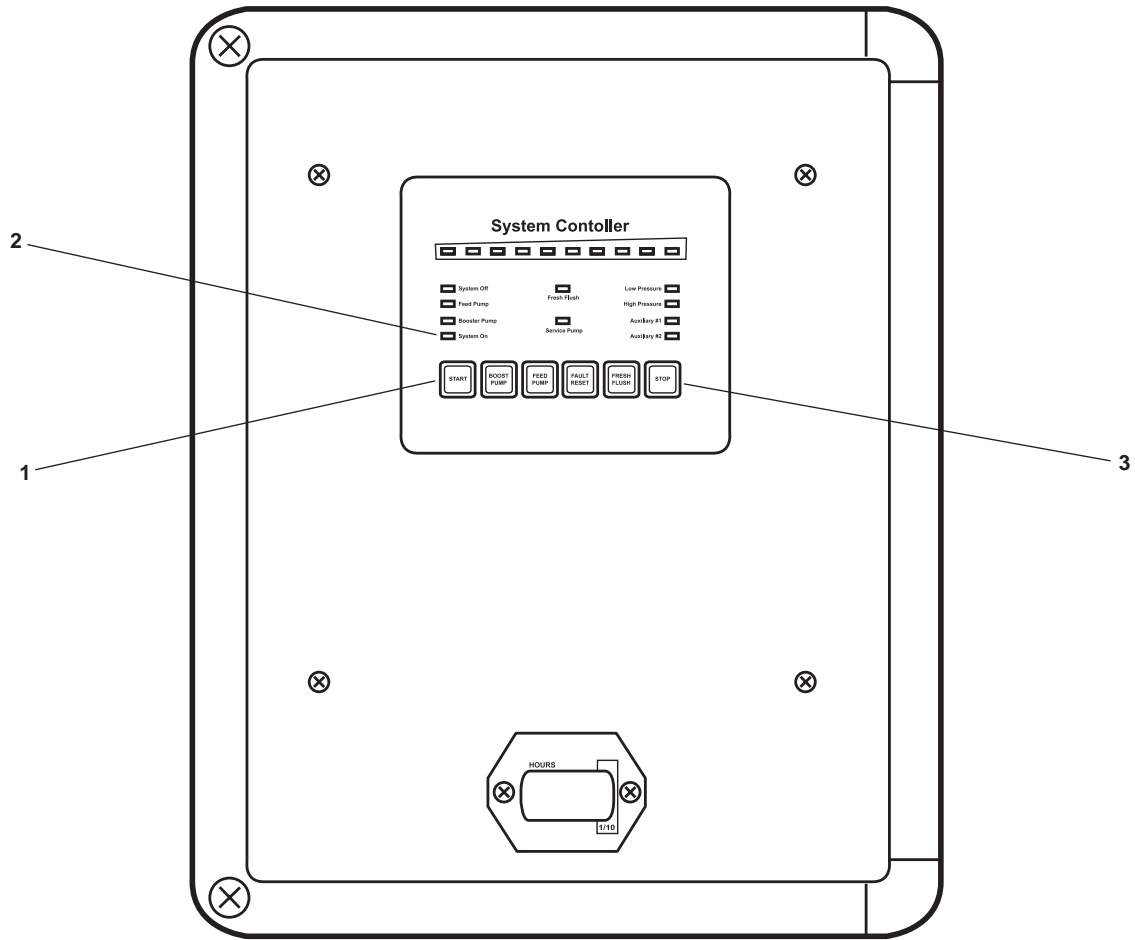

Figure 11. System Controller

END OF WORK PACKAGE

**OPERATOR MAINTENANCE
REVERSE OSMOSIS WATER PURIFICATION UNIT FOR
INLAND AND COASTAL LARGE TUG (LT)
MEDIA FILTER SUBASSEMBLY, SERVICE**

INITIAL SETUP:**Tools and Special Tools:**

Tool Kit, General Mechanic's (Item 1, Table 2,
WP 0031 00)
Electric Vacuum Cleaner (Item 4, Table 2,
WP 0031 00)

References (continued):

WP 0005 00
WP 0031 00
WP 0033 00
WP 0035 00

Materials/Parts:

Media Garnet, 8-12 (Item 12, Table 1,
WP 0035 00)
Lubricant, Silicone (Item 11, Table 1,
WP 0035 00)
Sand, Media (Item 15, Table 1, WP 0035 00)
Tag, Danger (Item 17, Table 1, WP 0035 00)
O-ring (Item 6, Figure 3, WP 0033 00)

Equipment Conditions:

General service water system operating in normal mode (TM 55-1925-273-10).
ROWPU 1 and 2 shut down (WP 0005 00).
CLOSE, lock out, and tag out (FM 55-502) valves RO-V-2, RO-V-3, and RO-V-10.
Set to OFF, lock out, and tag out (FM 55-502) the REVERSE OSMOSIS WATER MAKER No. 1 and the REVERSE OSMOSIS WATER MAKER No. 2 circuit breakers (**LT 803 Only**), or the LVP FOR REVERSE OSMOSIS WATER MAKER No. 1 and LVP FOR REVERSE OSMOSIS WATER MAKER No. 2 circuit breakers (**All Other Vessels**) at 440V power panel No. 5.

Personnel Required:

Two Watercraft Engineers, 88L

References:

FM 55-502
TM 55-1925-273-10

REPLACE MEDIA FILTER SUBSTRATE**DISASSEMBLY**

1. OPEN RO-V-11, media filter drain valve (figure 1, item 1) and permit the filter tank to drain to the port shaft alley. Allow time for the water in the media filter to fully drain before continuing with the procedure.
2. On top of the media filter, loosen and separate the inlet piping union (figure 2, item 1) from the inlet elbow (figure 2, item 2).
3. Remove the inlet elbow (figure 2, item 2) from the top of the media filter.
4. Remove and discard the o-ring (figure 2, item 3).
5. Use a wet/dry vacuum to remove the substrate from the media filter.

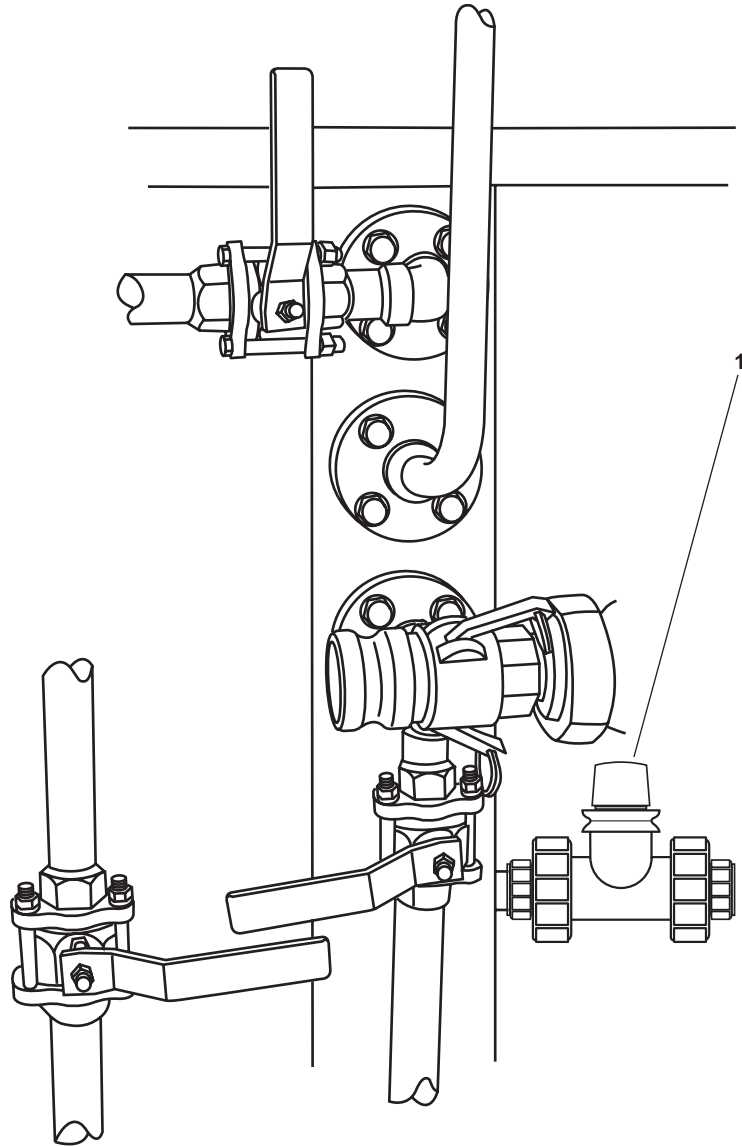

Figure 1. Media Filter Drain Valve

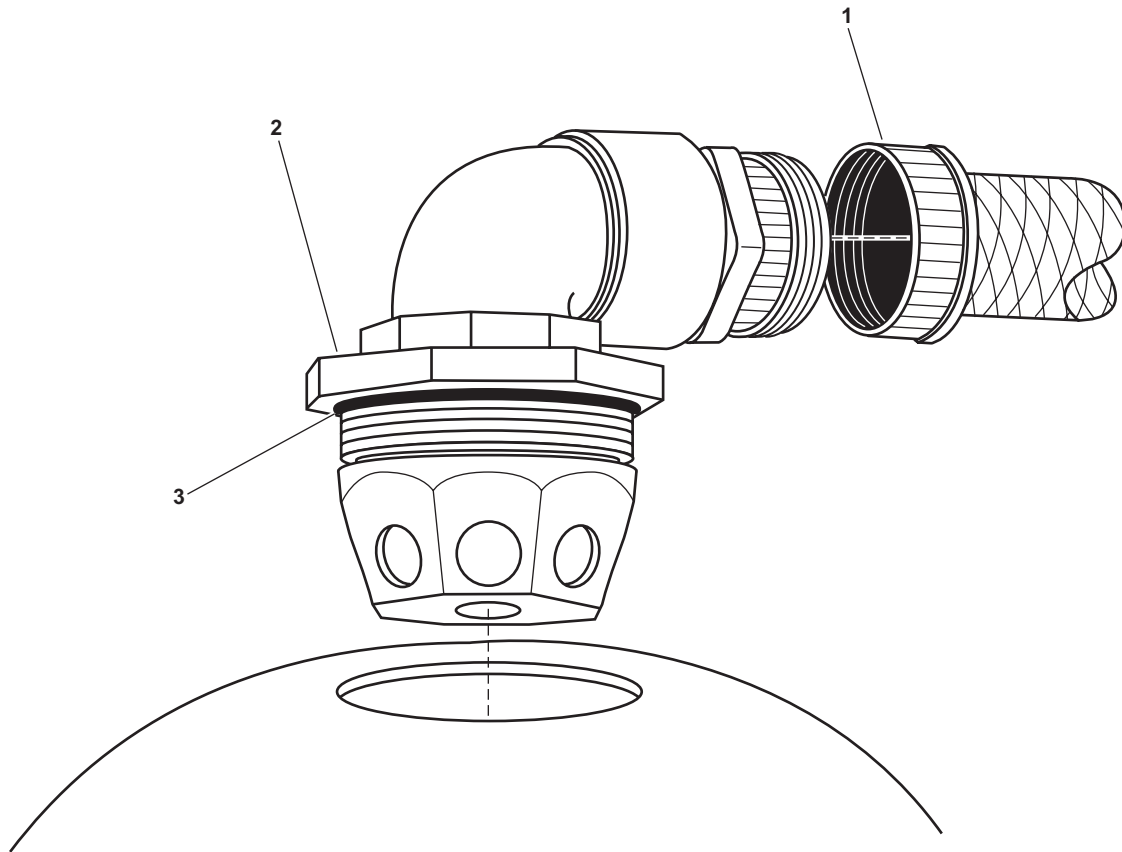

Figure 2. Media Filter

ASSEMBLY

1. CLOSE RO-V-11, media filter drain valve (figure 1, item 1).

▲ CAUTION

The media filter should be filled 2/3 full with substrate, at a ratio of two parts sand to one part gravel. Overfilling the media filter with too much substrate can cause damage to other systems cooled by the general service system, due to evacuation of the substrate during backflush and rinse cycles.

2. Place 200 lbs (90.7 kg) of media sand in the media filter.
3. Place 100 lbs (45.4 kg) of size 8-12 media garnet in the media filter.
4. Lubricate a new O-ring (figure 2, item 3) with silicone lubricant and install the O-ring on the inlet elbow (figure 2, item 2).
5. Install the inlet elbow (figure 2, item 2) in the media filter.
6. Install the inlet piping union (figure 2, item 1) to the inlet elbow (figure 2, item 2).
7. Remove the lockouts and tagouts (FM 55-502).

NOTE

The new media substrate contains fine particles and contaminates. The media filter must be back flushed and rinsed prior to use with the new substrate, or the downstream filters may clog.

8. Perform two media filter backflush operations (WP 0005 00).
9. Check the media filter for leaks.
10. Return the equipment to the desired readiness condition.

END OF WORK PACKAGE

**OPERATOR MAINTENANCE
REVERSE OSMOSIS WATER PURIFICATION UNIT FOR
INLAND AND COASTAL LARGE TUG (LT)
PREFILTRATION SUBASSEMBLY, SERVICE**

INITIAL SETUP:

Tools and Special Tools:

Tool Kit, General Mechanic's (Item 1, Table 2, WP 0031 00)

Personnel Required:

Two Watercraft Engineers, 88L

Materials/Parts:

Lubricant, Silicone (Item 11, Table 1, WP 0035 00)
Rag, Wiping (Item 14, Table 1, WP 0035 00)
Tag, Danger (Item 17, Table 1, WP 0035 00)
Filter Element (Item 5, Figure 4, WP 0033 00)
Filter Element (Item 10, Figure 4, WP 0033 00)
O-Ring (Item 2, Figure 4, WP 0033 00)
O-Ring (Item 9, Figure 4, WP 0033 00)

References:

FM 55-502
WP 0005 00
WP 0031 00
WP 0033 00
WP 0035 00

REPLACE FILTER ELEMENT

DISASSEMBLY

1. Shut down the applicable Reverse Osmosis Water Purification Unit (ROWPU) (WP 0005 00).
2. CLOSE, lock out, and tag out (FM 55-502) the applicable inlet sea water supply valve as shown in table 1.
3. Slowly, OPEN the filter air release valve (figure 1, item 1) on top of the filter housing lid (figure 1, item 2).
4. Allow any pressure to vent, or any fluid to drain.
5. Rotate the filter housing lid retaining ring (figure 1, item 3) counterclockwise, and remove it from the filter housing (figure 1, item 4).
6. Grasp the handles (figure 1, item 5), and remove the filter housing lid (figure 1, item 2) from the filter housing (figure 1, item 4).
7. Remove and discard the lid O-ring (figure 1, item 6).
8. Remove the filter element (figure 1, item 7) from the filter housing (figure 1, item 4) and discard.
9. Thoroughly clean the interior of the filter housing (figure 1, item 4) with fresh water and clean rags.
10. Remove all debris and foreign matter from the filter housing (figure 1, item 4).
11. Thoroughly clean the filter housing lid (figure 1, item 2) using fresh water and clean rags.

Table 1. Inlet Sea Water Supply Lockout/Tagout Guide

ROWPU	Specific Filter	Valve
1	20-Micron Filter Element	RO-V-1-1
1	5-Micron Filter Element	RO-V-1-1
2	20-Micron Filter Element	RO-V-2-1
2	5-Micron Filter Element	RO-V-2-1

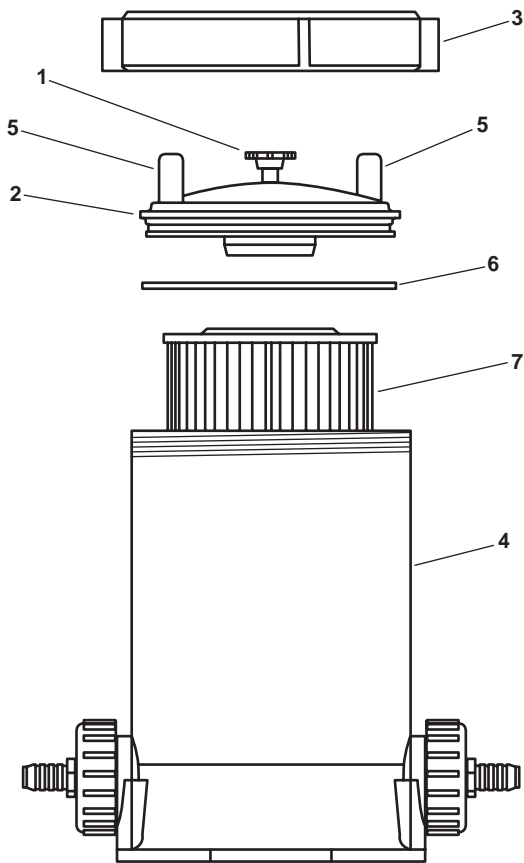

Figure 1. Filter Assembly

ASSEMBLY

1. Install a new filter element (figure 1, item 7) in the filter housing (figure 1, item 4).
2. Lubricate the new O-ring (figure 1, item 6) with silicone lubricant, and install it on the filter housing lid (figure 1, item 2).
3. Place the filter housing lid (figure 1, item 2) on top of the filter housing (figure 1, item 4) and push the lid down into the filter housing.
4. Place the lid retaining ring (figure 1, item 3) in position over the filter housing lid (figure 1, item 2), and rotate clockwise until snug.
5. Remove the lockouts and tagouts (FM 55-502).
6. OPEN the air release valve (figure 1, item 1).
7. Perform a fresh water flush (WP 0005 00) on the ROWPU with the air release valve (figure 1, item 1) OPEN on the serviced filter.

8. When the filter housing (figure 1, item 4) is full of water, as indicated by a solid stream of water flowing from the air release valve (figure 1, item 1), CLOSE the air release valve.
9. Dry the work area and check the ROWPU for leaks.
10. Return the equipment to the desired readiness condition (WP 0005 00).

END OF WORK PACKAGE

**OPERATOR MAINTENANCE
REVERSE OSMOSIS WATER PURIFICATION UNIT FOR
INLAND AND COASTAL LARGE TUG (LT)
HIGH PRESSURE PUMP, SERVICE**

INITIAL SETUP:

Tools and Special Tools:

Tool Kit, General Mechanic's (Item 1, Table 2, WP 0031 00)
Suitable Drain Pan

Materials/Parts (continued):

Rag, Wiping (Item 14, Table 1, WP 0035 00)
Tag, Danger (Item 17, Table 1, WP 0035 00)

Materials/Parts:

Dry Cleaning Solvent (Item 5, Table 1, WP 0035 00)
Gloves, Chemical and Oil Protective (Item 3, Table 3, WP 0034 00)
Goggles, Industrial (Item 4, Table 3, WP 0034 00)
Pump Oil (Item 13, Table 1, WP 0035 00)

Personnel Required:

Two Watercraft Engineers, 88L

References:

FM 55-502
WP 0005 00
WP 0031 00
WP 0034 00
WP 0035 00

CHANGE HIGH PRESSURE PUMP OIL



Replace or repair components only after the affected circuit has been secured, locked out, and tagged out. Performing replacement with the circuit energized may result in serious injury or death.

1. Perform shutdown for the applicable Reverse Osmosis Water Purification Unit (ROWPU) (WP 0005 00).
2. CLOSE, lock out, and tag out (FM 55-502) the applicable inlet sea water supply valve as shown in table 1.

Table 1. ROWPU Lockout/Tagout Guide

ROWPU	Specific Breaker	Inlet Sea Water Valve
1	REVERSE OSMOSIS WATER MAKER No. 1 (LT 803 Only) LVP FOR REVERSE OSMOSIS WATER MAKER No. 1 (All Other Vessels)	RO-V-1-1
2	REVERSE OSMOSIS WATER MAKER No. 2 (LT 803 Only) LVP FOR REVERSE OSMOSIS WATER MAKER No. 2 (All Other Vessels)	RO-V-2-1

3. At 440V power panel No. 5, set to OFF, lock out, and tag out (FM 55-502) the applicable ROWPU circuit breaker as shown in table 1.
4. Place a suitable drain pan under the applicable high pressure pump oil drain plug (figure 1, item 1).

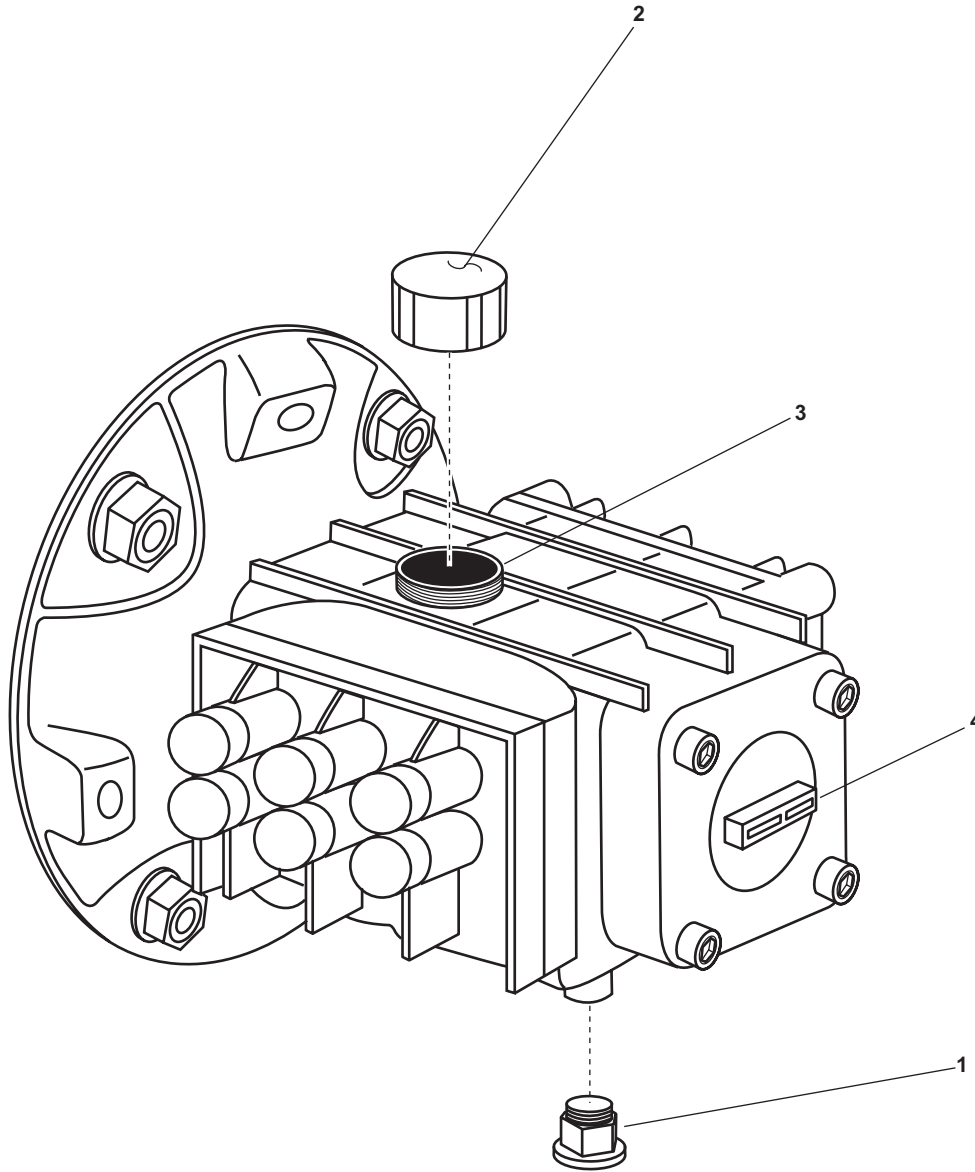
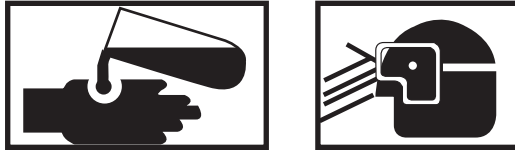

Figure 1. High Pressure Pump

WARNING

Do not allow hydraulic fluid, engine oil, or cleaning solvents to come in contact with unprotected skin or eyes. Prolonged skin contact can cause illness or injury. Eye contact can cause serious injury. Always wear chemical protective gloves and goggles when handling hydraulic fluid, engine oil, and cleaning solvents. Failure to follow these precautions can result in illness or serious injury.

5. Unscrew the high pressure pump oil cap (figure 1, item 2), from the oil fill port (figure 1, item 3).
6. Remove the high pressure pump oil drain plug (figure 1, item 1).
7. Allow time for the oil to drain completely from the high pressure pump.
8. Install the high pressure pump oil drain plug (figure 1, item 1).
9. Pour high pressure oil through the oil fill port (figure 1, item 3) until it just covers the sight glass (figure 1, item 4). Do not overfill.
10. Install the high pressure pump oil cap (figure 1, item 2).

WARNING

Dry cleaning solvent is flammable and its vapor is potentially explosive. Do not use dry cleaning solvent in the vicinity of spark, open flame, or excessive heat. Do not use dry cleaning solvent in unventilated spaces. Failure to follow these precautions can result in death or serious injury.

11. Use cleaning solvent and wiping rags to thoroughly clean the work area.
12. Remove the lockouts and tagouts (FM 55-502).
13. Conduct an operational test by completing the applicable ROWPU startup procedure (WP 0005 00), and check for any oil leaks at the high pressure pump.
14. Return the equipment to the desired readiness condition.

END OF WORK PACKAGE

Chapter 6

**Unit Maintenance Instructions
for
Reverse Osmosis Water Purification Unit
Inland and Coastal Large Tug (LT)**

**UNIT MAINTENANCE
REVERSE OSMOSIS WATER PURIFICATION UNIT FOR
INLAND AND COASTAL LARGE TUG (LT)
REVERSE OSMOSIS WATER PURIFICATION UNIT, REPAIR**

INITIAL SETUP:

Tools and Special Tools:

Tool Kit, General Mechanic's (Item 1, Table 2, WP 0031 00)
Multimeter (Item 3, Table 2, WP 0031 00)

Personnel Required:

Two Watercraft Engineers, 88L

Materials/Parts:

Rag, Wiping (Item 14, Table 1, WP 0035 00)
Tag, Danger (Item 17, Table 1, WP 0035 00)
Tape, Antiseizing (Item 18, Table 1, WP 0035 00)

References:

FM 55-502
WP 0005 00
WP 0031 00
WP 0035 00

REPAIR LOW PRESSURE HOSE

DISASSEMBLY



Replace or repair components only after the affected circuit has been secured, locked out, and tagged out. Performing replacement with the circuit energized may result in serious injury or death.

1. Perform the Shutdown procedure (WP 0005 00) on the applicable Reverse Osmosis Water Purification Unit (ROWPU).
2. CLOSE, lock out, and tag out (FM 55-502) the applicable ROWPU inlet sea water supply valve as shown in table 1.

Table 1. ROWPU Lockout/Tagout Guide

ROWPU	Specific Breaker	Inlet Sea Water Valve
1	REVERSE OSMOSIS WATER MAKER No. 1 (LT 803 Only) LVP FOR REVERSE OSMOSIS WATER MAKER No. 1 (All Other Vessels)	RO-V-1-1
2	REVERSE OSMOSIS WATER MAKER No. 2 (LT 803 Only) LVP FOR REVERSE OSMOSIS WATER MAKER No. 2 (All Other Vessels)	RO-V-2-1

3. At 440V power panel No. 5, set to OFF, lock out, and tag out (FM 55-502) the applicable ROWPU circuit breaker as shown in table 1.
4. Loosen the hose clamps (figure 1, item 1) at both ends of the hose (figure 1, item 2) and remove the hose from the fittings (figure 1, item 3).

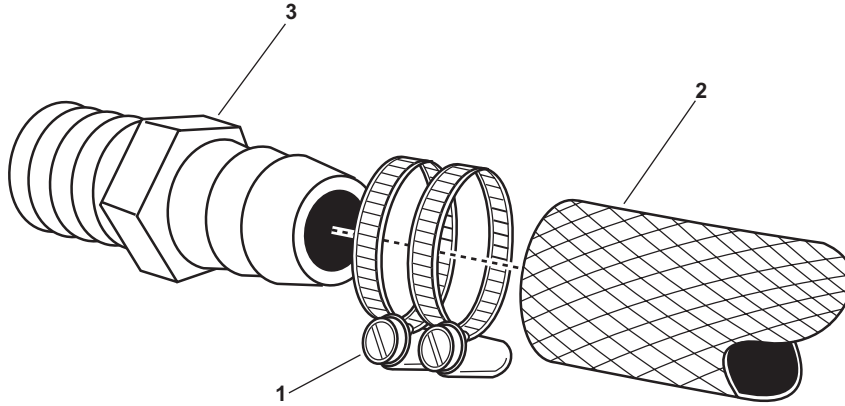

Figure 1. Low Pressure Fitting, Hose, and Clamp

ASSEMBLY

1. If a new hose is required, cut a new length of hose from bulk using the old hose as a template.
2. Place the hose clamps (figure 1, item 1) over the hose (figure 1, item 2).
3. Place the ends of the hose (figure 1, item 2) over the fittings (figure 1, item 3).
4. Tighten the hose clamps (figure 1, item 1).
5. Remove the lockouts and tagouts (FM 55-502).
6. Perform the Follow-On Service procedure at the end of this work package.

REPLACE LOW PRESSURE FITTINGS

REMOVAL

1. Perform the Shutdown procedure (WP 0005 00) on the applicable ROWPU.
2. CLOSE, lock out, and tag out (FM 55-502) the applicable ROWPU inlet sea water supply valve as shown in table 1.
3. At 440V power panel No. 5, set to OFF, lock out, and tag out (FM 55-502) the applicable ROWPU circuit breaker as shown in table 1.
4. Loosen the hose clamps (figure 1, item 1), and remove the hose (figure 1, item 2) from the fitting (figure 1, item 3).
5. Remove the damaged fitting (figure 1, item 3).

INSTALLATION

1. Place antiseizing tape on the male threads of the replacement fitting (figure 1, item 3) and install the replacement fitting.
2. Place the end of the hose (figure 1, item 2) on the fitting (figure 1, item 3).
3. Tighten the hose clamps (figure 1, item 1).
4. Remove the lockouts and tagouts (FM 55-502).
5. Perform the Follow-On Service procedure at the end of this work package.

ADJUST PRESSURE REGULATOR VALVE**DISSASSEMBLY**

1. Remove the protective cap (figure 2, item 1) from the pressure regulator valve (figure 2, item 2).
2. Loosen the locking nut (figure 2, item 3) on the pressure regulator valve (figure 2, item 2).
3. Perform the Media Filter Backflush procedure (WP 0005 00) steps 1-7.

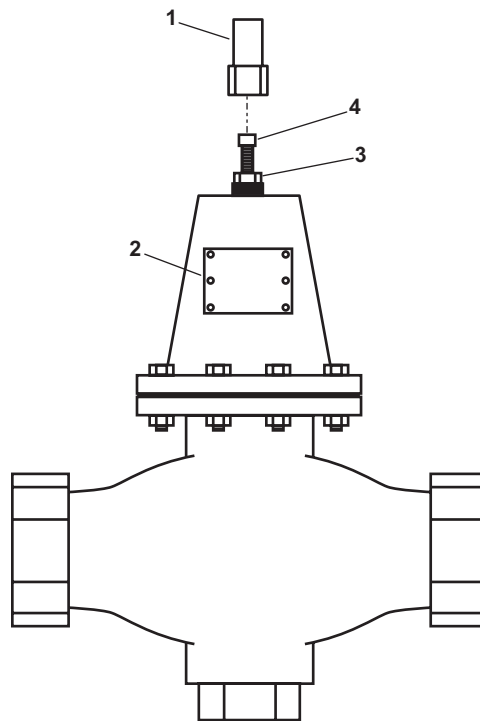

Figure 2. ROWPU System Pressure Regulator Valve

⚠ CAUTION

Media tank inlet pressure must not exceed 45 PSI (3.1 bar) and differential pressure must not exceed 35 PSI (2.4 bar), or damage could occur to the media filter tank.

4. Turn the adjustment screw (figure 2, item 4) clockwise to increase system pressure or counterclockwise to decrease system pressure as indicated on the media filter INLET PRESSURE gauge RO-PG-2 (figure 3, item 1).
5. Adjust media tank inlet pressure to a maximum of 45 PSI (3.1 bar).

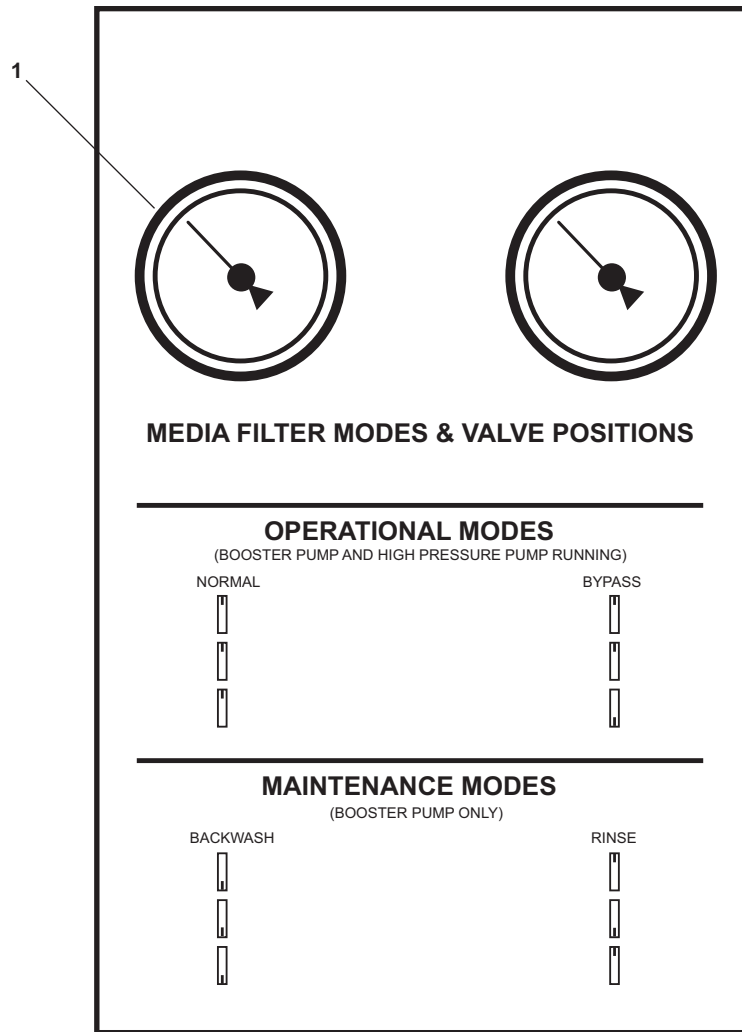

Figure 3. Media Filter Gauges

ASSEMBLY

1. Tighten the locknut (figure 2, item 3) on the pressure regulator valve (figure 2, item 2).
2. Verify that ROWPU system pressure remains constant.
3. Perform the Media Filter Backflush procedure (WP 0005 00) steps 8-16.
4. Install the protective cap (figure 2, item 1) on the pressure regulator valve (figure 2, item 2).
5. Perform the Follow-On Service procedure at the end of this work package.

ROWPU 24 VDC FUSE REPLACEMENT**REMOVAL**

1. Set to OFF, lock out, and tag out (FM 55-502) the A.C. SWITCH (figure 4, item 1) at the ROWPU battery charger (figure 4, item 2).

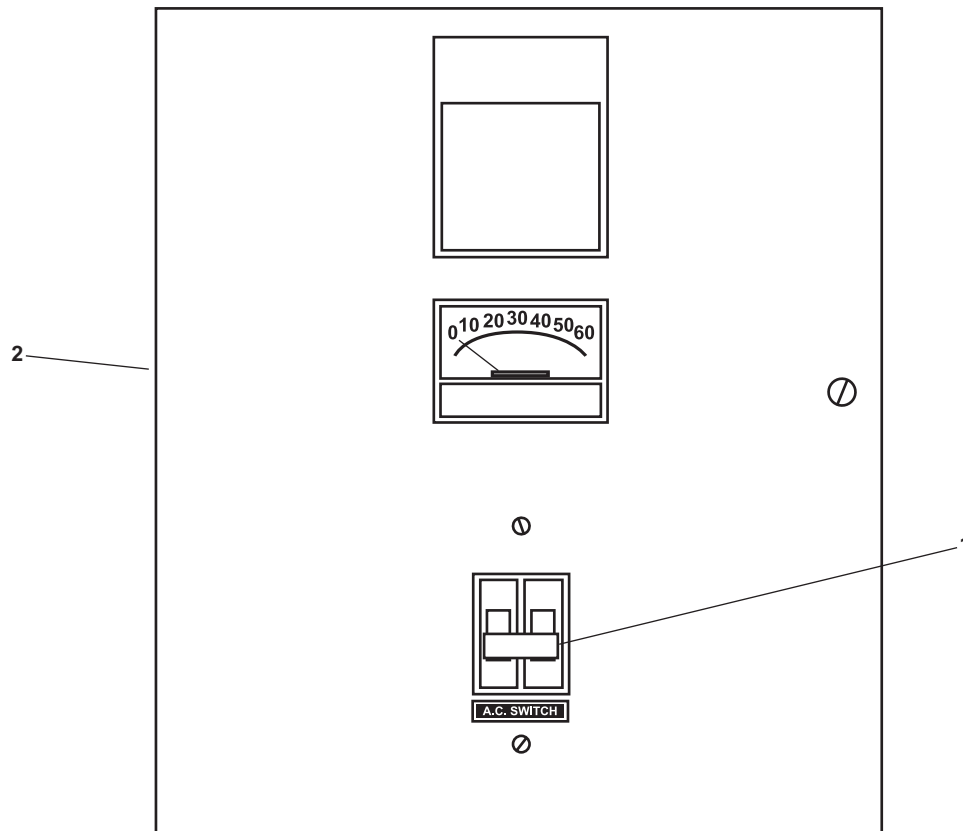

Figure 4. ROWPU Battery Charger

2. Remove the six wingnuts (figure 5, item 1) that secure the ROWPU battery box cover (figure 5, item 2).
3. Remove the ROWPU battery box cover (figure 5, item 2).
4. Remove the negative battery cable (figure 5, item 3) from the ROWPU battery (figure 5, item 4).

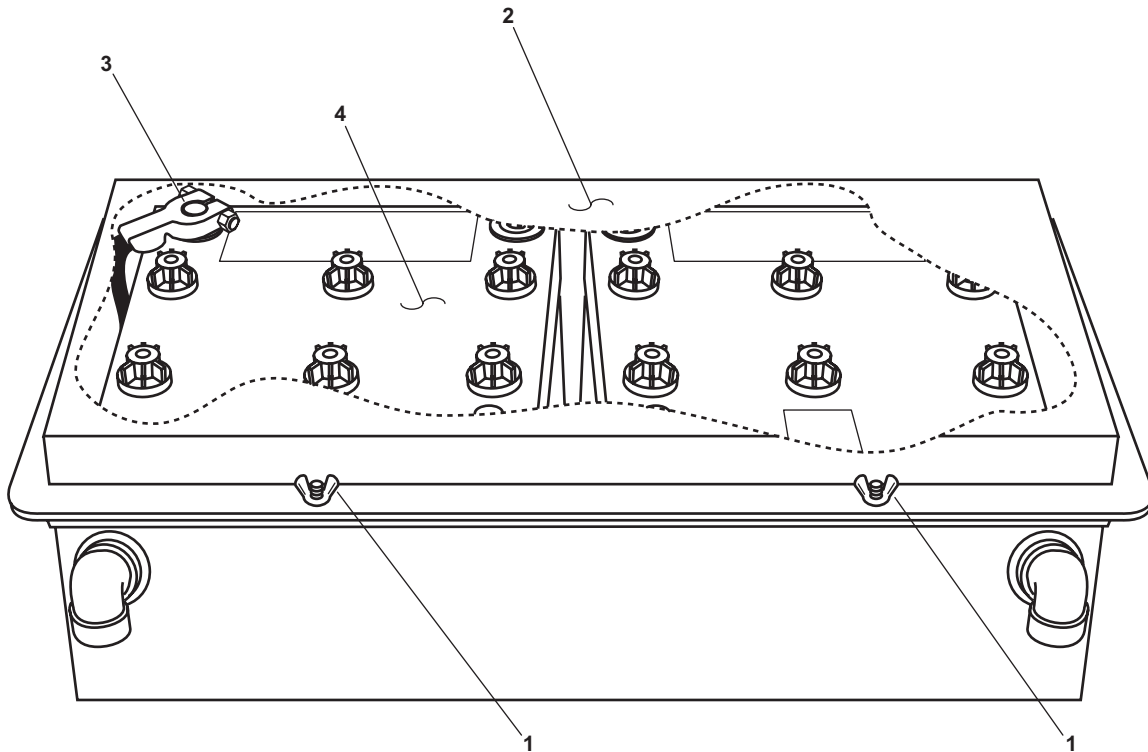

Figure 5. ROWPU Battery

5. Loosen the four captive screws (figure 6, item 1) on the fuse box cover (figure 6, item 2), and remove the cover from the fuse box (figure 6, item 3).



Replace or repair components only after the affected circuit has been secured, locked out, and tagged out. Performing replacement with the circuit energized may result in serious injury or death.

6. Take voltage readings with a multimeter on both sides of the fuses (figure 6, item 4) to ensure that electrical circuits are deenergized. If voltage is present, ensure that the proper switch is OFF, locked out, and tagged out (FM 55-502) and that the correct ROWPU battery terminals are disconnected. If no voltage is present, proceed with the procedure.
7. Remove the fuses (figure 6, item 4) from the fuse box (figure 6, item 3).

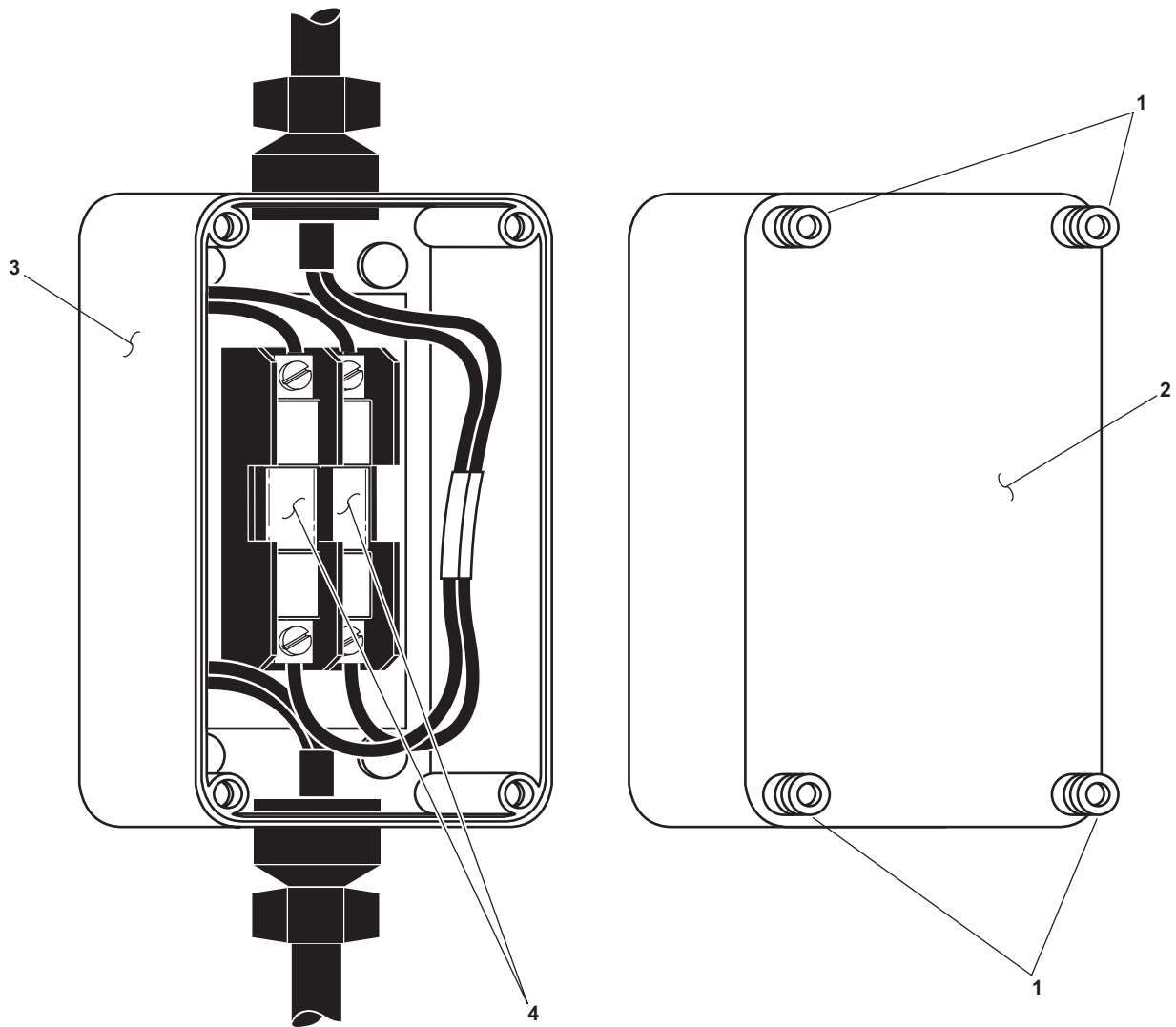

Figure 6. ROWPU 24 Vdc Fuse Box

INSTALLATION

1. Install the fuses (figure 6, item 4) in the fuse box (figure 6, item 3).
2. Install the fuse box cover (figure 6, item 2), and secure it with the four captive screws (figure 6, item 1).
3. Install the negative battery cable (figure 5, item 3) on the ROWPU battery (figure 5, item 4).
4. Install the ROWPU battery box cover (figure 5, item 2), and secure it with the six wingnuts (figure 5, item 1).
5. Remove the lockouts and tagouts (FM 55-502).
6. Set to ON the A.C. SWITCH (figure 4, item 1) at the ROWPU battery charger (figure 4, item 2).
7. Perform the Follow-On Service procedure at the end of this work package.

BACKFLOW PREVENTER VALVE REPAIR

DISASSEMBLY

1. Set to OFF the FWF PUMP circuit breaker (figure 7, item 1) at the 24 Vdc control panel. Lock out and tag out (FM 55-502).

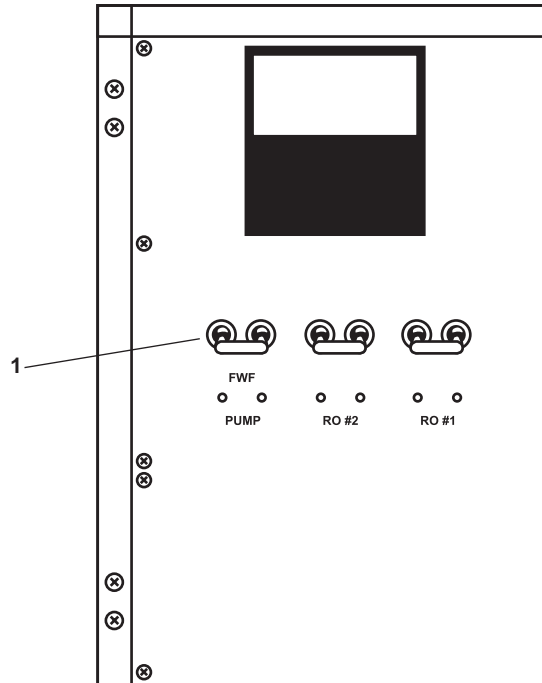

Figure 7. 24 Vdc Control Panel

2. CLOSE the backflow preventer supply valve RO-V-6 (figure 8, item 1). Lock out and tag out (FM 55-502).
3. CLOSE the backflow preventer discharge valve RO-V-7 (figure 8, item 2). Lock out and tag out (FM 55-502).
4. Remove the four cover bolts (figure 8, item 3) and remove the valve cover (figure 8, item 4) from the valve body (figure 8, item 5).

NOTE

The cover O-ring, diaphragm, and stem may remain attached to the valve cover, and can usually be removed as an assembly.

5. Remove the cover O-ring (figure 8, item 6), diaphragm (figure 8, item 7), and stem (figure 8, item 8). Discard the cover O-ring and diaphragm.
6. Remove the valve spring (figure 8, item 9).
7. Remove the retainer (figure 8, item 10) from the valve body (figure 8, item 5).

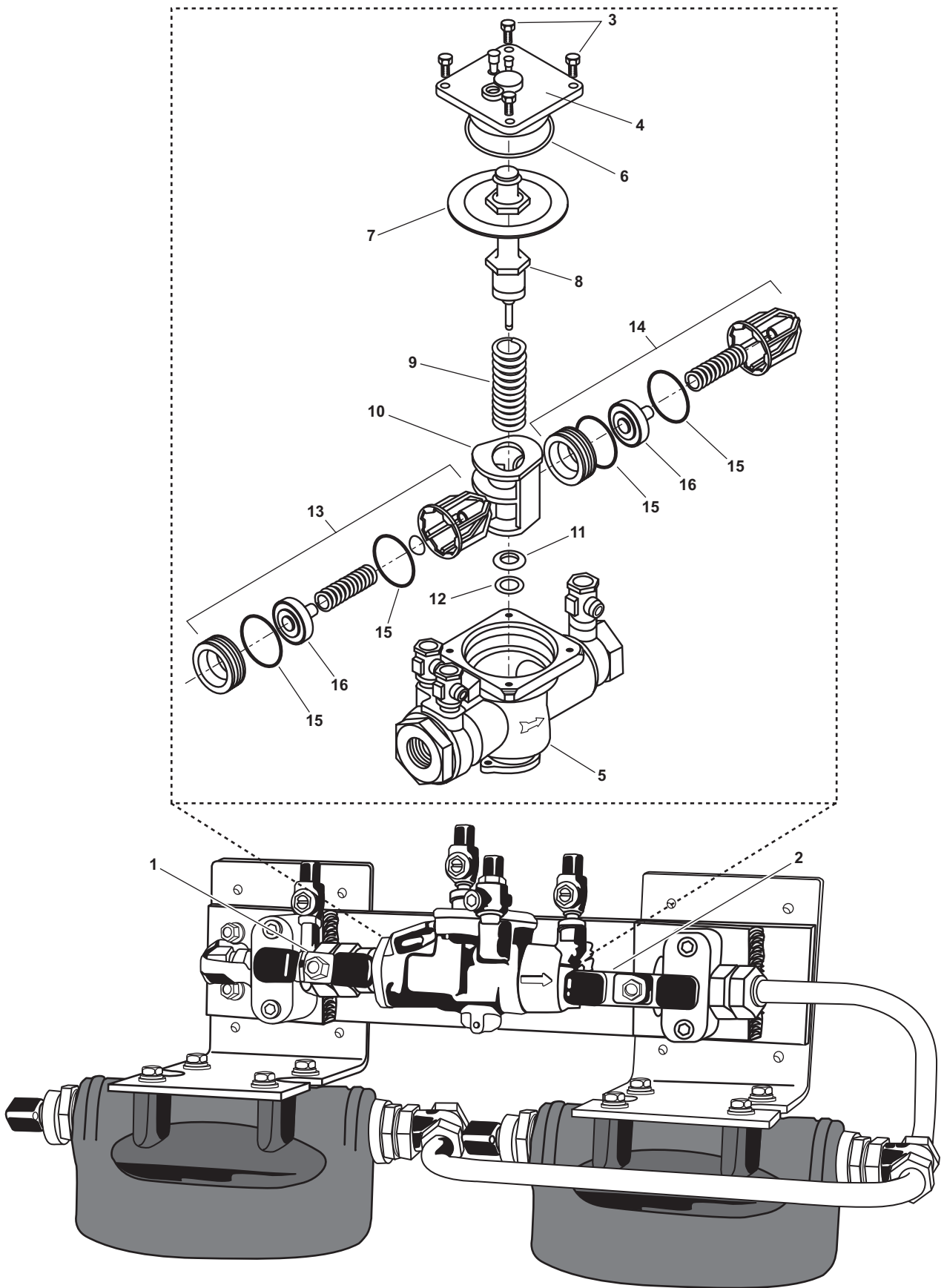

Figure 8. Backflow Preventer Valve

8. Remove the seat (figure 8, item 11), and seat O-ring (figure 8, item 12) from the valve body (figure 8, item 5). Discard the seat and seat O-ring.
9. Remove the first check assembly (figure 8, item 13) and second check assembly (figure 8, item 14) from the valve body (figure 8, item 5).

NOTE

The check seats are attached to the check cage with a bayonet type locking arrangement. Hold the check cage in one hand while turning the seat clockwise to disassemble the parts of the check assembly.

The seats and springs of the first and second check assemblies are not interchangeable. The heavier spring and smaller diameter seat belong with the first check assembly.

10. Hold the check cage in one hand while turning the seat clockwise to separate the parts of the first check assembly (figure 8, item 13) and the second check assembly (figure 8, item 14).
11. Remove and discard the O-ring seals (figure 8, item 15) and disc assemblies (figure 8, item 16) from the first check assembly (figure 8, item 13) and second check assembly (figure 8, item 14).
12. Use clean wiping rags and water to clean and remove any debris and foreign matter from the interior of the valve body (figure 8, item 5), and clean all remaining parts with fresh water.

ASSEMBLY

NOTE

The seats and springs of the first and second check assemblies are not interchangeable. The heavier spring and smaller diameter seat belong with the first check assembly.

The check seats are attached to the check cage with a bayonet type locking arrangement. Hold the check cage in one hand while turning the seat clockwise to assemble the parts of the check assembly.

1. Assemble the first check assembly (figure 8, item 13) and second check assembly (figure 8, item 14) using new O-ring seals (figure 8, item 15) and disc assemblies (figure 8, item 16).
2. Install the first check assembly (figure 8, item 13) and second check assembly (figure 8, item 14) in the valve body (figure 8, item 5).
3. Install a new seat O-ring (figure 8, item 12) and a new seat (figure 8, item 11) in the valve body (figure 8, item 5).
4. Install the retainer (figure 8, item 10) in the valve body (figure 8, item 5).
5. Install the valve spring (figure 8, item 9) by centering it on the seat (figure 8, item 11) in the valve body (figure 8, item 5).
6. Assemble the a new diaphragm (figure 8, item 7) and new stem (figure 8, item 8) as an assembly.
7. Install the new stem (figure 8, item 8) and a new diaphragm (figure 8, item 7) in the valve body (figure 8, item 5).
8. Install a new cover O-ring (figure 8, item 6) on the valve cover (figure 8, item 4).

 **CAUTION**

When installed, if the valve cover will not press flat against the valve body, the stem is cocked inside the backflow preventer valve. Failure to properly align the stem before tightening the cover bolts can result in damage to the backflow preventer valve.

9. Install the valve cover (figure 8, item 4) with the new cover O-ring (figure 8, item 6) on the valve body (figure 8, item 5). Verify that the valve cover presses flat against the valve body.
10. Install the four cover bolts (figure 8, item 3) to secure the valve cover in place (figure 8, item 4).
11. Remove the lockouts and tagouts (FM 55-502).
12. Set to ON the FWF PUMP circuit breaker (figure 7, item 1) at the 24 Vdc control panel.
13. Perform the ROWPU Fresh Water Flush procedure (WP 0005 00) and check for leaks and for proper operation of the backflow preventer valve.
14. Perform the Follow-On Service procedure at the end of this work package.

FOLLOW-ON SERVICE

1. Operate the ROWPU under normal conditions (WP 0005 00).
2. Check for proper operation of the system.
3. Return the equipment to the desired readiness condition.

END OF WORK PACKAGE

**UNIT MAINTENANCE
REVERSE OSMOSIS WATER PURIFICATION UNIT FOR
INLAND AND COASTAL LARGE TUG (LT)
FRESH WATER FLUSH PUMP, REPLACE**

INITIAL SETUP:**Tools and Special Tools:**

Tool Kit, Electrician's (Item 2, Table 2,
WP 0031 00)
Multimeter (Item 3, Table 2, WP 0031 00)

Materials/Parts:

Tag, Danger (Item 17, Table 1, WP 0035 00)
Pump (Item 1, Figure 2, WP 0033 00)

Personnel Required:

Two Watercraft Engineers, 88L

References:

FM 55-502

References (continued):

TB 43-0218
WP 0005 00
WP 0014 00
WP 0031 00
WP 0033 00
WP 0035 00

Equipment Conditions:

Set to OFF, lock out, and tag out (FM 55-502) the FWF
PUMP circuit breaker, at the 24 Vdc control panel.
CLOSE, lock out, and tag out (FM 55-502) valves RO-
V-7 and RO-V-9.

WARNING

Never reuse locking hardware. Reuse of locking hardware such as lockwashers, locking nuts, cotter pins, and lockwire can result in undetected loosening of fastening hardware causing catastrophic component failure resulting in death, injury, or damage to equipment. In accordance with TB 43-0218, ensure that all locking hardware is discarded upon removal and replaced with new.

REMOVAL

1. Remove the four screws (figure 1, item 1) securing the junction box cover (figure 1, item 2).
2. Remove the junction box cover (figure 1, item 2).

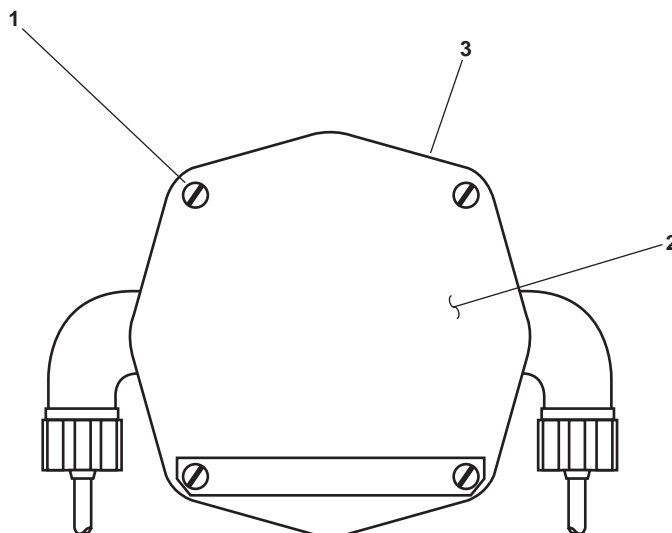

Figure 1. Electrical Junction Box

WARNING

Take great care when working around energized electrical equipment. Contact between unprotected body parts and electrical conductors can cause serious injury or death. Do not wear jewelry or other conductive items while servicing energized electrical equipment. Failure to comply with these precautions can cause serious injury or death.

3. Take voltage readings with a multimeter, measuring across all connection points in the junction box (figure 1, item 3), to ensure that electrical circuits are deenergized. If voltage is present, ensure that the proper circuit breaker is OFF, locked out, and tagged out (FM 55-502). If no voltage is present, proceed with the procedure.
4. Label and disconnect the fresh water flush pump wires in the junction box (figure 1, item 3).
5. Loosen the hose clamps (figure 2, item 1) on the inlet hose (figure 2, item 2).
6. Disconnect the hose (figure 2, item 2) from the inlet fitting (figure 2, item 3).
7. Disconnect the outlet line (figure 3 item 1) from the outlet fitting (figure 3, item 2).

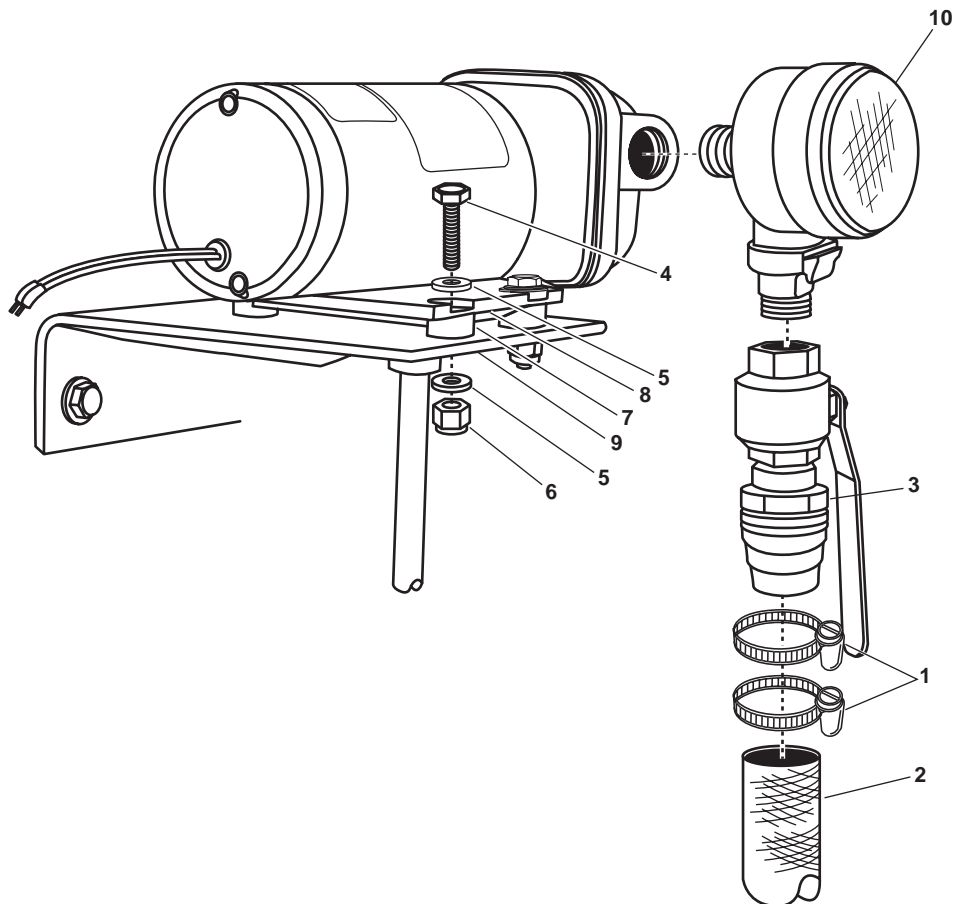

Figure 2. Fresh Water Flush Pump (Inlet Side)

8. Remove four bolts (figure 2, item 4), eight flat washers (figure 2, item 5), four nylock nuts (figure 2, item 6), and four rubber grommets (figure 2, item 7) that secure the pump (figure 2, item 8) to the foundation (figure 2, item 9). Discard the nyloc nuts.
9. Remove the fresh water flush pump (figure 2, item 8).
10. Remove the outlet fitting (figure 3, item 2) from the fresh water flush pump (figure 3, item 3).
11. Remove the inlet strainer (figure 2, item 10) from the fresh water flush pump (figure 2, item 8)

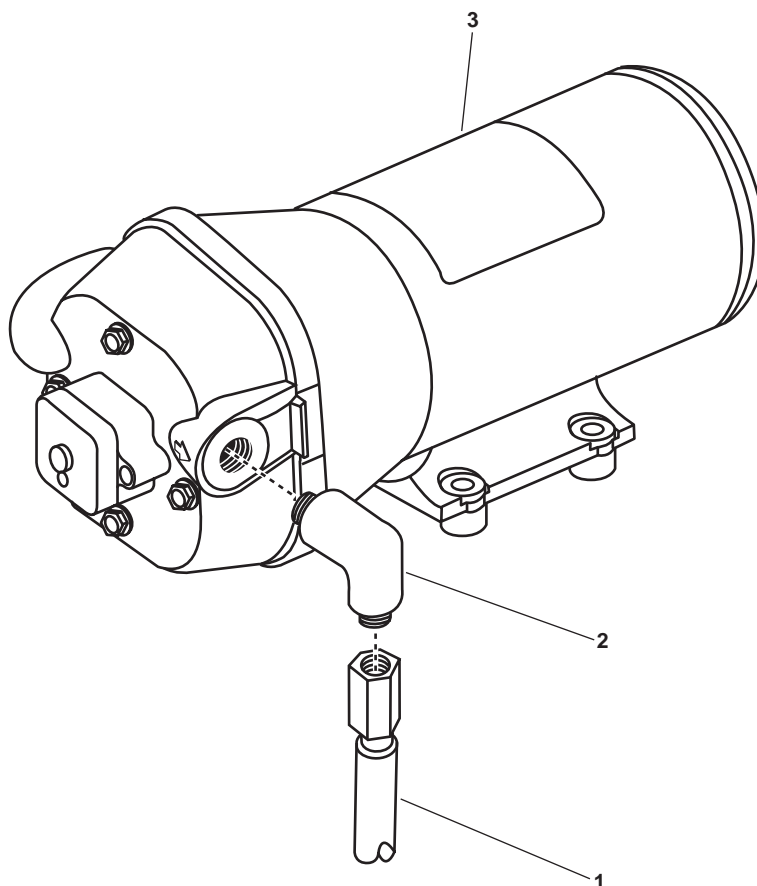

Figure 3. Fresh Water Flush Pump (Outlet Side)

INSTALLATION

1. Perform the Service Fresh Water Flush Pump Inlet Strainer procedure (WP 0014 00).
2. Install the inlet strainer (figure 2, item 10) on the fresh water flush pump (figure 2, item 8).
3. Install the outlet fitting (figure 3, item 2) in the fresh water flush pump (figure 3, item 3).
4. Place the fresh water flush pump (figure 2, item 8) on the foundation (figure 2, item 9), and secure it in place with four bolts (figure 2, item 4), eight flat washers (figure 2, item 5), 4 rubber grommets (figure 2, item 7) and four new nylock nuts (figure 2, item 6).
5. Install the inlet hose (figure 2, item 2), and secure it with the hose clamps (figure 2 item 1).

6. Connect the outlet line (figure 3 item 1) to the outlet fitting (figure 3, item 2).
7. Route the wiring to the junction box (figure 1, item 3), and connect the wiring using the marks and labels from step 4 in Removal as a guide. Remove the labels.
8. Install the junction box cover (figure 1, item 2).
9. Remove the lockouts and tagouts (FM 55-502).
10. Perform a fresh water flush (WP 0005 00) to verify operation of the fresh water flush pump.
11. Check the fresh water flush pump for leaks and proper operation.
12. Return the equipment to the desired readiness condition.

END OF WORK PACKAGE

**UNIT MAINTENANCE
REVERSE OSMOSIS WATER PURIFICATION UNIT FOR
INLAND AND COASTAL LARGE TUG (LT)
MEDIA FILTER SUBASSEMBLY, REPAIR**

INITIAL SETUP:**Tools and Special Tools:**

Tool Kit, General Mechanic's (Item 1, Table 2, WP 0031 00)
Torque Wrench, 0-600 IN-LB (Item 7, Table 2, WP 0031 00)
Suitable Drain Pan

References:

FM 55-502
TB 43-0218
WP 0005 00
WP 0031 00
WP 0033 00
WP 0035 00

Materials/Parts:

Compound, Antiseize (Item 4, Table 1, WP 0035 00)
Rag, Wiping (Item 14, Table 1, WP 0035 00)
Tag, Danger (Item 17, Table 1, WP 0035 00)
Valve Rebuild Kit, 3/4" Sil Braze (Figure 1, WP 0033 00)
Valve Rebuild Kit, 1" Sil Braze (Figure 1, WP 0033 00)

Equipment Conditions:

Reverse Osmosis Water Purification Unit (ROWPU) 1 and 2 shut down (WP 0005 00).
CLOSE, lock out, and tag out (FM 55-502) valve RO-V-1 Main Sea Water Supply Valve.
Set to OFF, lock out, and tag out (FM 55-502) the REVERSE OSMOSIS WATER MAKER No. 1 and REVERSE OSMOSIS WATER MAKER No. 2 circuit breakers (**LT 803 Only**), or the LVP FOR REVERSE OSMOSIS WATER MAKER No. 1 and LVP FOR REVERSE OSMOSIS WATER MAKER No. 2 circuit breakers (**All Other Vessels**) at 440V power panel No. 5.

Personnel Required:

Two Watercraft Engineers, 88L

WARNING

Never reuse locking hardware. Reuse of locking hardware such as lockwashers, locking nuts, cotter pins, and lock wire can result in undetected loosening of fastening hardware causing catastrophic component failure resulting in death, injury, or damage to equipment. In accordance with TB 43-0218, ensure that all locking hardware is discarded upon removal and replaced with new.

REPAIR SIL BRAZE BALL VALVE**DISASSEMBLY**

1. Cycle the affected valve handle (figure 1, item 1) to drain any fluid, and remove any pressure from the valve body cavity.
2. Unscrew and remove the three sets of nuts (figure 1, item 2) and lockwashers (figure 1, item 3) from the bolts (figure 1, item 4). Discard the lockwashers (figure 1, item 3).
3. Pull the end fittings (figure 1, item 5) free of the valve body (figure 1, item 6).
4. Remove the gaskets (figure 1, item 7) and seats (figure 1, item 8) from the end fittings (figure 1, item 5). Discard the gaskets.
5. Remove the cavity filler (figure 1, item 9) from the ball (figure 1, item 10), and discard.

▲ CAUTION

Take care not to scratch or nick the ball in any way, or leaks could occur in the repaired valve.

6. Turn the stem (figure 1, item 11), to position the ball (figure 1, item 10), to the CLOSED position, and remove the ball from the valve body (figure 1, item 6).

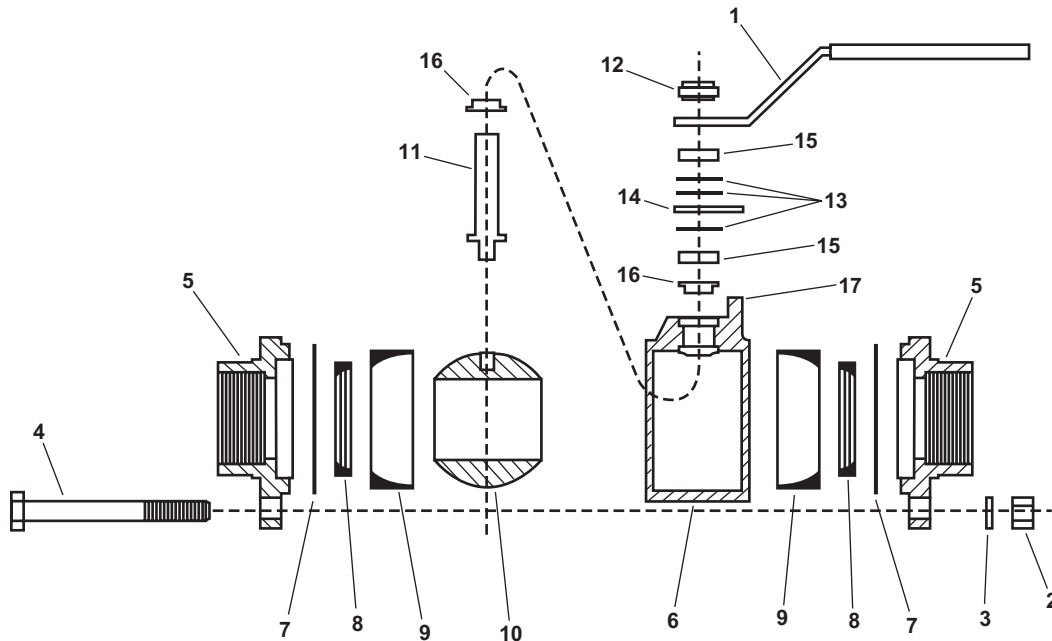

Figure 1. Sil Braze Ball Valve

7. Unscrew and remove the locking jam nut (figure 1, item 12) from the handle (figure 1, item 1), and remove the handle. Discard the jam nut (figure 1, item 12).
8. Remove the three spring washers (figure 1, item 13), stop disk (figure 1, item 14), and followers (figure 1, item 15) from the stem (figure 1, item 11). Discard the spring washers (figure 1, item 13).
9. Push the stem (figure 1, item 11) down and out of the open end of the valve body (figure 1, item 6).
10. Remove the upper and lower valve packing (figure 1, item 16) and discard.
11. Examine the parts of the valve for damage and wear, and clean all parts using clean water and wiping rags.

ASSEMBLY

1. Place the new bottom packing (figure 1, item 16) over the stem (figure 1, item 11) with the flanged surface seated against the flange on the stem.
2. Insert the stem (figure 1, item 11) into the valve body (figure 1, item 6) bore.
3. Install the new upper packing (figure 1, item 16) over the stem (figure 1, item 11) with the flanged surface facing upward, and push the packing into the valve body (figure 1, item 6) counter bore.

4. Install the bottom follower (figure 1, item 15) over the stem (figure 1, item 11), and push it into place in contact with the upper packing (figure 1, item 16).
5. Lubricate the valve stem (figure 1, item 11) threads with antiseizing compound.
6. Install the first new spring washer (figure 1, item 13) over the stem (figure 1, item 11) with the concave side facing upward.
7. Install the stop disk (figure 1, item 14).
8. Install the second new spring washer (figure 1, item 13) with the concave side facing downward, resting on the stop disk (figure 1, item 14).
9. Install the third spring new washer (figure 1, item 13) with the concave side facing upward.
10. Install the top follower (figure 1, item 15) on the stem (figure 1, item 11) in contact with the third new spring washer (figure 1, item 13).
11. Install the handle (figure 1, item 1) over the top follower (figure 1, item 15) on the stem (figure 1, item 11) such that the handle is over the stop pin (figure 1, item 17) on the stop disk (figure 1, item 14) when the valve is in the OPEN position.
12. Install a new jam nut (figure 1, item 12) on the stem (figure 1, item 11) to retain the handle (figure 1, item 1) in place. Tighten the jam nut until all spring washers (figure 1, item 13) are fully compressed and then loosen 1/8th of a turn.
13. Install new seats (figure 1, item 8) in the end fittings (figure 1, item 5) with the flat end of the seat inserted in the flat recess in the end fitting.
14. Install new gaskets (figure 1, item 7) on the end fittings (figure 1, item 5).
15. Rotate the stem (figure 1, item 11) to position the valve to the CLOSED position.
16. Insert the ball (figure 1, item 10) into the valve body (figure 1, item 6).

 **CAUTION**

Take care not to scratch or nick the ball in any way, or leaks could occur in the repaired valve.

17. Carefully, slide the tang of the stem (figure 1, item 11) into the recess on top of the ball (figure 1, item 10), taking care not to scratch or nick the ball.
18. Rotate the valve handle (figure 1, item 1) to the OPEN position.
19. Install the cavity fillers (figure 1, item 9) in the ball (figure 1, item 10).
20. Insert the valve body (figure 1, item 6) into position in the end fittings (figure 1, item 5).
21. Rotate the valve handle (figure 1, item 1) to the CLOSED position.
22. Install the three sets of nuts (figure 1, item 2), new lockwashers (figure 1, item 3) and bolts (figure 1, item 4), hand tight.

23. With a wrench, tighten each nut (figure 1, item 2) until the lockwashers (figure 1, item 3) begin to compress. Tighten in the sequence shown in figure 2.
24. Continue to tighten each nut (figure 1, item 2) 1/8th of a turn at a time in the sequence shown in figure 2. Tighten to a torque value of:
 - a. 60 lb-in (6.8 Nm) measured at the stem for 3/4" ball valves
 - b. 72 lb-in (8.1 Nm) measured at the stem for 1" ball valves
25. Remove the lockouts and tagouts (FM 55-502).
26. Perform ROWPU startup (WP 0005 00), and check the valve for leaks.
27. Return the equipment to the desired readiness condition.

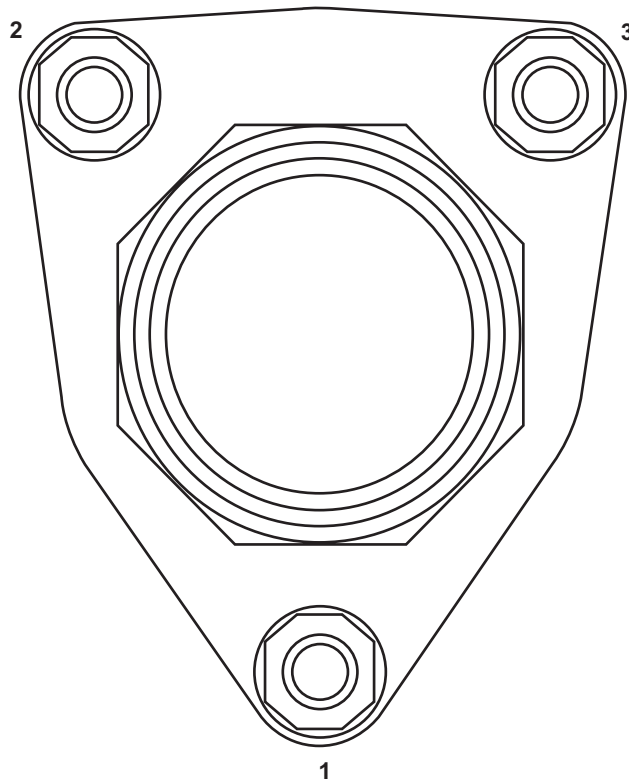

Figure 2. Torque Pattern for Sil Braze Ball Valve

END OF WORK PACKAGE

**UNIT MAINTENANCE
REVERSE OSMOSIS WATER PURIFICATION UNIT FOR
INLAND AND COASTAL LARGE TUG (LT)
HIGH PRESSURE PUMP, REPLACE**

INITIAL SETUP:

Tools and Special Tools:

Tool Kit, Electrician's (Item 2, Table 2, WP 0031 00)
Multimeter (Item 3, Table 2, WP 0031 00)

Materials/Parts:

Tag, Danger (Item 17, Table 1, WP 0035 00)
High Pressure Pump (Item 1, Figure 5, WP 0033 00)

Personnel Required:

Two Watercraft Engineers, 88L

References:

FM 55-502

References (continued):

TB 43-0218
WP 0005 00
WP 0017 00
WP 0031 00
WP 0033 00
WP 0035 00

Equipment Conditions:

CLOSE, lock out, and tag out (FM 55-502) valve RO-V-9.
Set to OFF, lock out, and tag out (FM 55-502) the FWF PUMP circuit breaker at the Reverse Osmosis Water Purification Unit (ROWPU) 24 Vdc control panel.

WARNING

Never reuse locking hardware. Reuse of locking hardware such as lockwashers, locking nuts, cotter pins, and lock wire can result in undetected loosening of fastening hardware causing catastrophic component failure resulting in death, injury, or damage to equipment. In accordance with TB 43-0218, ensure that all locking hardware is discarded upon removal and replaced with new.

REMOVAL

1. CLOSE, lock out, and tag out (FM 55-502) the applicable inlet sea water supply valve as shown in table 1.
2. At the 440V power panel No. 5, set to OFF, lock out and tag out (FM 55-502) the applicable circuit breaker as shown in table 1.

Table 1. Lockout/Tagout Guide

ROWPU	Specific Breaker	Inlet Sea Water Valve
1	REVERSE OSMOSIS WATER MAKER No. 1 (LT 803 Only) LVP FOR REVERSE OSMOSIS WATER MAKER No. 1 (All Other Vessels)	RO-V-1-1
2	REVERSE OSMOSIS WATER MAKER No. 2 (LT 803 Only) LVP FOR REVERSE OSMOSIS WATER MAKER No. 2 (All Other Vessels)	RO-V-2-1

3. At the applicable high pressure pump motor, remove the four screws (figure 1, item 1) that secure the junction box cover (figure 1, item 2). Remove the junction box cover.



Take great care when working around energized electrical equipment. Contact between unprotected body parts and electrical conductors can cause serious injury or death. Do not wear jewelry or other conductive items while servicing energized electrical equipment. Failure to comply with these precautions can cause serious injury or death.

Replace or repair components only after the affected circuit has been secured, locked out, and tagged out. Performing replacement with the circuit energized may result in injury.

4. Take voltage readings with a multimeter, measuring at the connection points in the junction box (figure 1, item 3), to ensure that electrical circuits are deenergized. If voltage is present, ensure that the proper circuit breakers are OFF, locked out, and tagged out (FM 55-502). If no voltage is present, continue with the procedure.
5. Label and disconnect the wires, and remove the cabling (figure 1, item 4) from the junction box (figure 1, item 3) of the applicable high pressure pump.
6. Slowly, loosen the clamp (figure 1, item 5) to the low pressure hose (figure 1, item 6) until water begins to drain from the fitting.
7. Allow any pressure to vent, or any fluid to drain.
8. Remove the low pressure hose (figure 1, item 6) from the low pressure fitting (figure 1, item 7).
9. Remove the low pressure fitting (figure 1, item 7) from the high pressure pump (figure 1, item 8).
10. Remove the high pressure hose (figure 1, item 9) from the high pressure fitting (figure 1, item 10).
11. Remove the high pressure fitting (figure 1, item 10) from the high pressure pump (figure 1, item 8).
12. Remove four bolts (figure 1, item 11), four nuts (figure 1, item 12), eight flat washers (figure 1, item 13) and four lockwashers (figure 1, item 14) that secure the high pressure pump (figure 1, item 8) to its mounting plate (figure 1, item 15), and remove the high pressure pump.
13. Discard the lockwashers.

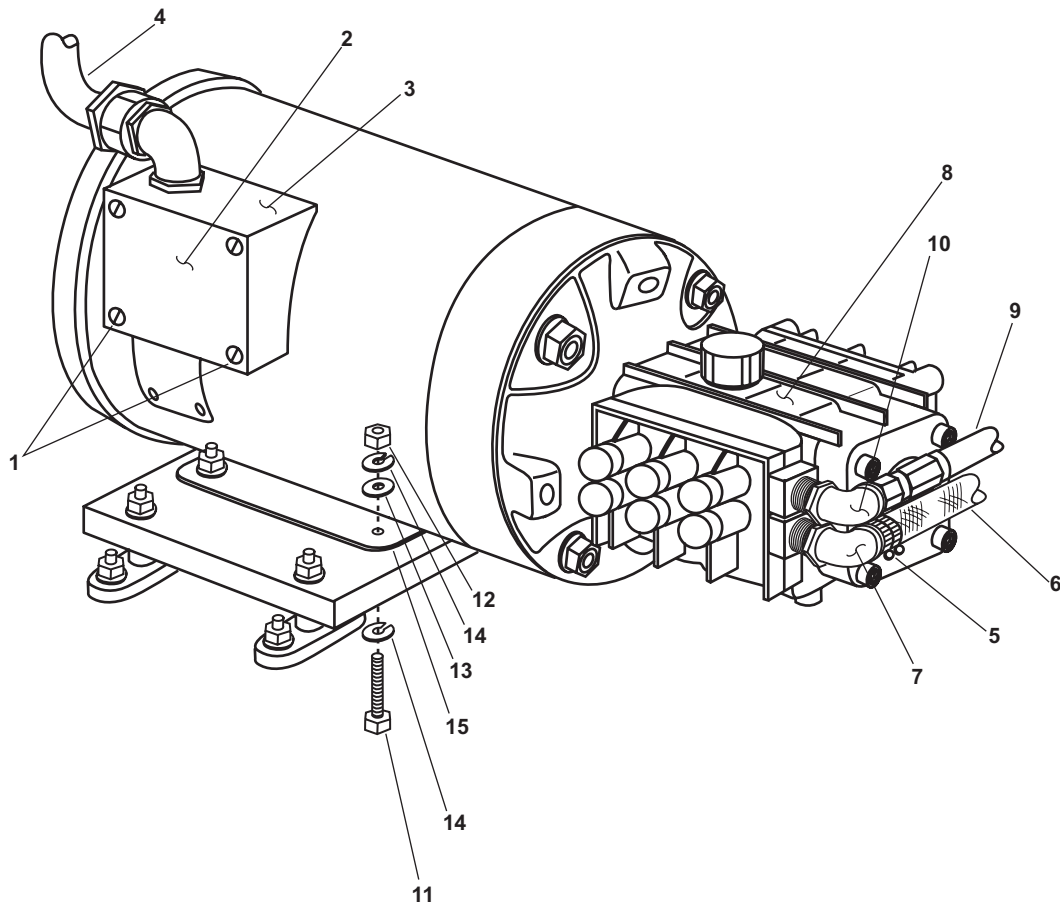

Figure 1. High Pressure Pump

INSTALLATION

1. Place the high pressure pump (figure 1, item 8) on the mounting plate (figure 1, item 15), and secure it in place with four bolts (figure 1, item 11), eight flat washers (figure 1, item 13), four new lockwashers (figure 1, item 14) and four nuts (figure 1, item 12).
2. Install the high pressure fitting (figure 1, item 10) into the high pressure pump (figure 1, item 8).
3. Install the low pressure fitting (figure 1, item 7) into the high pressure pump (figure 1, item 8).
4. Install the low pressure hose (figure 1, item 6), and secure it in place with the clamp (figure 1, item 5).
5. Install the high pressure hose (figure 1, item 9).
6. Install the cable (figure 1, item 4) and connect the wiring using the marks and labels from step 5 of Removal as a guide.
7. Install the junction box cover (figure 1, item 2), and secure it in place with four screws (figure 1, item 1).
8. Service the applicable high pressure pump (WP 0017 00).

9. Remove the lockouts and tagouts (FM 55-502).
10. Perform the startup (WP 0005 00) on the applicable ROWPU, and check for leaks in the area of the high pressure pump (figure 1, item 8).
11. Verify proper operation of the high pressure pump (figure 1, item 8). Ensure there are no unusual noises or vibration, and that the ROWPU operates at proper system pressure.
12. Return the equipment to the desired readiness condition.

END OF WORK PACKAGE

UNIT MAINTENANCE
REVERSE OSMOSIS WATER PURIFICATION UNIT FOR
INLAND AND COASTAL LARGE TUG (LT)
MEMBRANE AND VESSEL SUBASSEMBLY; REPLACE, REPAIR

INITIAL SETUP:**Tools and Special Tools:**

Tool Kit, General Mechanic's (Item 1, Table 2,
 WP 0031 00)

Materials/Parts:

Lubricant, Silicone (Item 11, Table 1,
 WP 0035 00)
 Rag, Wiping (Item 14, Table 1, WP 0035 00)
 Tag, Danger (Item 17, Table 1, WP 0035 00)
 Tape, Antiseizing (Item 18, Table 1,
 WP 0035 00)

References:

FM 55-502
 TB 43-0218
 WP 0005 00
 WP 0031 00
 WP 0035 00

Equipment Conditions:

CLOSE, lock out, and tag out (FM 55-502) valve
 RO-V-7.

Personnel Required:

Two Watercraft Engineers, 88L

WARNING

Never reuse locking hardware. Reuse of locking hardware such as lockwashers, locking nuts, cotter pins, and lockwire can result in undetected loosening of fastening hardware causing catastrophic component failure resulting in death, injury, or damage to equipment. In accordance with TB 43-0218, ensure that all locking hardware is discarded upon removal and replaced with new.

HIGH PRESSURE MEMBRANE AND VESSEL SUBASSEMBLY REPLACEMENT**REMOVAL**

WARNING



Replace or repair components only after the affected circuit has been secured, locked out, and tagged out. Performing replacement with the circuit energized may result in serious injury or death.

1. CLOSE, lock out, and tag out (FM 55-502) the applicable Reverse Osmosis Water Purification Unit (ROWPU) inlet sea water supply valve and ROWPU brine discharge valve as shown in table 1.
2. At 440V power panel No. 5, set to OFF, lock out, and tag out (FM 55-502) the applicable circuit breaker as shown in table 1.

■ Table 1. ROWPU Lockout/Tagout Guide

ROWPU	Specific Breaker	Inlet Sea Water Valve	Brine Discharge Valve
1	REVERSE OSMOSIS WATER MAKER No. 1 (LT 803 Only) LVP FOR REVERSE OSMOSIS WATER MAKER No. 1 (All Other Vessels)	RO-V-1-1	RO-V-1-2
2	REVERSE OSMOSIS WATER MAKER No. 2 (LT 803 Only) LVP FOR REVERSE OSMOSIS WATER MAKER No. 2 (All Other Vessels)	RO-V-2-1	RO-V-2-2

3. Label and disconnect all hoses (figure 1, item 1) from the applicable membrane and vessel subassembly (figure 1, item 2).
4. Remove the four bolts (figure 2, item 1), the four lockwashers (figure 2, item 2), and the four flat washers (figure 2, item 3). Discard the lockwashers.
5. Remove the U-brackets (figure 2, item 4) and the membrane and vessel subassembly (figure 2, item 5).

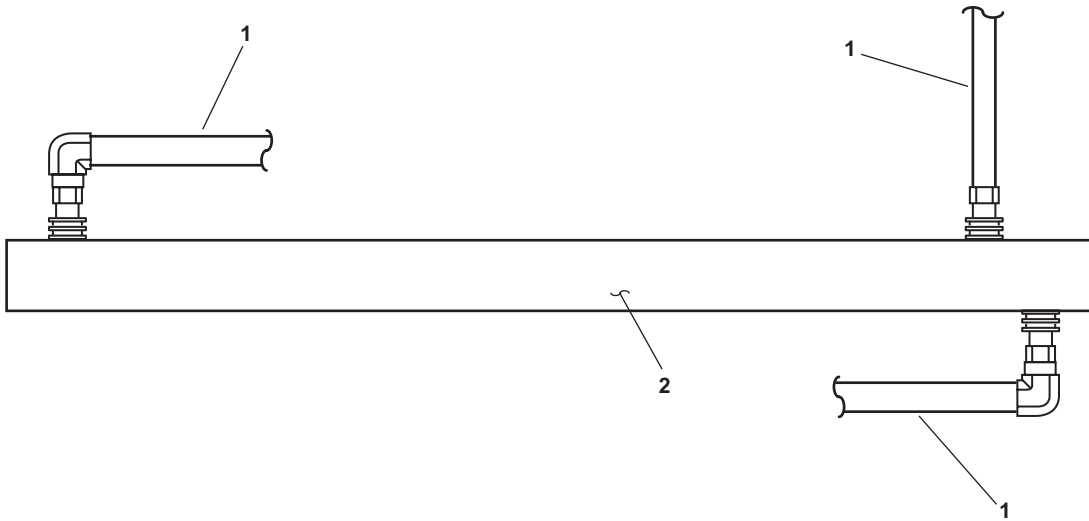

Figure 1. Reverse Osmosis Membrane and Vessel Subassembly

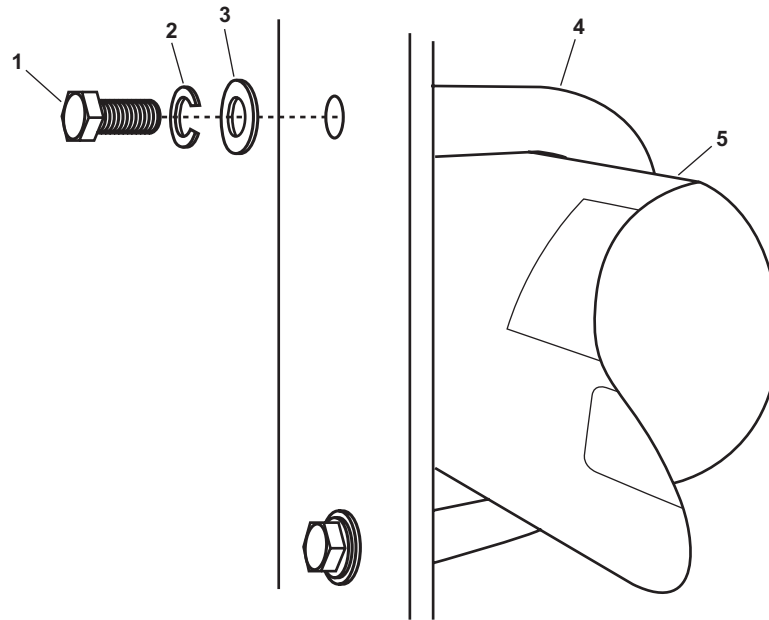

Figure 2. Membrane Mounting Hardware

INSTALLATION

1. Install the membrane and vessel subassembly (figure 2, item 5), and secure it in place with the U-brackets (figure 2, item 4), four sets of bolts (figure 2, item 1), four new lockwashers (figure 2, item 2), and four flat washers (figure 2, item 3).
2. Install the hoses (figure 1, item 1) on the applicable membrane and vessel subassembly (figure 1, item 2) using the labels from step 3 of Removal as a guide. Tighten finger tight plus one $\frac{1}{4}$ turn. Discard the labels.
3. Remove the lockouts and tagouts (FM 55-502).
4. Conduct fresh water flush (WP 0005 00) on the applicable ROWPU.
5. Conduct an operational test of the applicable ROWPU by completing the startup procedure (WP 0005 00) and observing normal operation indications.
6. Check for any leaks at the applicable membrane and vessel subassembly.
7. Return the equipment to the desired readiness condition.

REVERSE OSMOSIS (RO) MEMBRANE AND VESSEL SUBASSEMBLY REPAIR

DISASSEMBLY

1. Perform the Membrane and Vessel Subassembly Replacement Removal procedure in this work package.
2. Remove the product water fitting (figure 3, item 1) from the high pressure vessel (figure 3, item 2).
3. Remove the three allen head screws (figure 3, item 3) from each end of the high pressure vessel (figure 3, item 2).

4. Push inward on each end plug (figure 3, item 4), and remove the three piece segment ring (figure 3, item 5) from each end of the high pressure vessel (figure 3, item 2).
5. Remove the high pressure fitting retainer (figure 3, item 6) from each end of the high pressure vessel (figure 3, item 2).
6. Remove the high pressure fitting (figure 3, item 7) and O-ring (figure 3, item 8) from each end of the high pressure vessel (figure 3, item 2). Discard the O-ring.
7. Loosely install the three allen head screws (figure 3, item 3) into each end plug (figure 3, item 4) inside the high pressure vessel (figure 3, item 2).
8. Use the three allen head screws (figure 3, item 3) as a handle to remove the end plugs (figure 3, item 4) from the high pressure vessel (figure 3, item 2). Discard the two O-rings (figure 3, item 9) on each end plug.
9. Remove the RO membrane element (figure 3, item 10) from the product water side of the high pressure vessel (figure 3, item 2). Discard the RO membrane element, the two product water O-rings (figure 3, item 11) and the brine seal (figure 3, item 12).
10. Use a clean rag and clean water to remove any biological film or debris from the interior of the high pressure vessel (figure 3, item 2).
11. Inspect the interior of the high pressure vessel (figure 3, item 2) for cracks and smoothness. Replace the high pressure vessel if the interior is not crack free and smooth.
12. Clean each end plug (figure 3, item 4) and the high pressure fittings (figure 3, item 7) with clean wiping rags and water.
13. Inspect each end plug (figure 3, item 4) and the high pressure fittings (figure 3, item 7) for damage and wear.

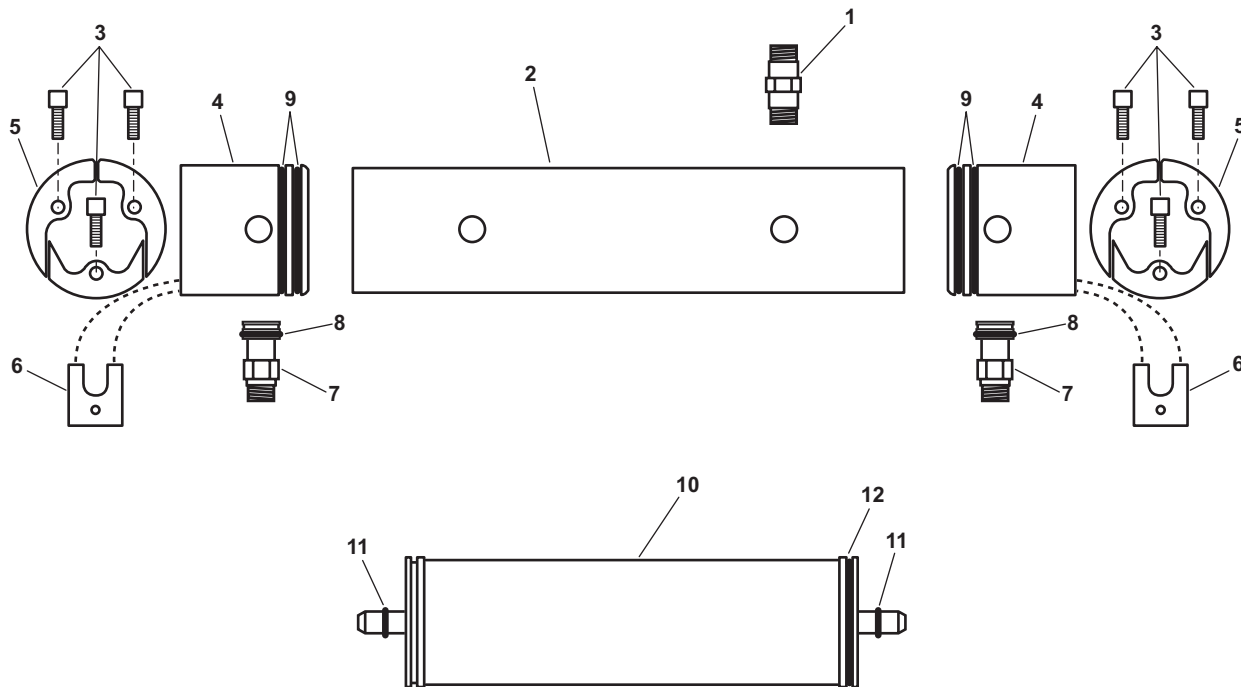

Figure 3. RO Membrane and Vessel Subassembly Repair

ASSEMBLY

1. Lightly lubricate two new product water O-rings (figure 3, item 11) with silicone lubricant and install the product water O-rings on the new RO membrane element (figure 3, item 10).

▲ CAUTION

Each end of the RO membrane element contains a ¾" x 1" product water tube. The outside surface is a sealing surface that separates the product water from the raw water. The outside sealing surface must remain scratch free. Never use any type of grabbing tool on or near the product water tube. Failure to comply with this caution will cause contamination of the product water and unreparable damage to the RO membrane element.

NOTE

The new RO membrane element comes complete with a brine seal installed on the product water outlet/raw water inlet side of the membrane. The brine outlet side of the new RO membrane does not have an O-ring installed.

2. Insert the brine outlet side of the new RO membrane element (figure 3, item 10) into the product water outlet side of the high pressure vessel (figure 3, item 2).
3. Slide the new RO element (figure 3, item 10) into the high pressure vessel (figure 3, item 2) until the brine seal (figure 3, item 12) is approximately 4 inches (102 mm) past the inside lip.
4. Lightly lubricate four new O-rings (figure 3, item 9) and install two new O-rings on each end plug (figure 3, item 4).
5. Push each end plug (figure 3, item 4) into the high pressure vessel (figure 3, item 2), ensuring that the high pressure ports, and the product water port, on the RO membrane (figure 3, item 10) are aligned with their respective holes in the high pressure vessel.
6. Continue to push each end plug (figure 3, item 4) into the high pressure vessel (figure 3, item 2) until the segmented ring grooves are exposed at each end of the high pressure vessel.
7. Verify that the high pressure ports and the product water port are still aligned with their respective holes in the high pressure vessel (figure 3, item 2).
8. Lightly lubricate two new O-rings (figure 3, item 8) with silicone lubricant, and install an O-ring on each high pressure fitting (figure 3, item 7).
9. Install a high pressure fitting (figure 3, item 7) with new O-rings (figure 3, item 8) in the high pressure ports at each end of the high pressure vessel (figure 3, item 2), and secure each in place with a high pressure fitting retainer (figure 3, item 6)
10. Wrap the male threads of the product water fitting (figure 3, item 1) with three layers of antiseizing tape.
11. Install the product water fitting (figure 3, item 1) on the high pressure vessel (figure 3, item 2). Tighten until two or three threads are exposed from the end plug (figure 3, item 4). Use no tools, and do not over tighten.
12. Install a three piece segment ring (figure 3, item 5) in each end of the high pressure vessel (figure 3, item 2) and secure each of the six segments in place with three allen head screws (figure 3, item 3) at each end.
13. Perform the High Pressure Vessel Subassembly Replacement Installation procedure in this work package.

END OF WORK PACKAGE

**UNIT MAINTENANCE
REVERSE OSMOSIS WATER PURIFICATION UNIT FOR
INLAND AND COASTAL LARGE TUG (LT)
CHARCOAL FILTER, SERVICE**

INITIAL SETUP:**Tools and Special Tools:**

Tool Kit, General Mechanic's (Item 1, Table 2,
WP 0031 00)

Materials/Parts:

Lubricant, Silicone (Item 11, Table 1,
WP 0035 00)
Rag, Wiping (Item 14, Table 1, WP 0035 00)
Tag, Danger (Item 17, Table 1, WP 0035 00)
Briquette, Carbon (Filter Element) (Item 3,
Figure 7, WP 0033 00)
O-Ring (Item 2, Figure 7, WP 0033 00)

Personnel Required:

Two Watercraft Engineers, 88L

References:

FM 55-502
WP 0005 00

References (continued):

WP 0031 00
WP 0033 00
WP 0035 00

Equipment Conditions:

Reverse Osmosis Water Purification Unit (ROWPU)
1 and 2 shut down (WP 0005 00).
Set to OFF, lock out, and tag out (FM 55-502) the
the REVERSE OSMOSIS WATER MAKER No.
1 and REVERSE OSMOSIS WATER MAKER
No. 2 circuit breakers (**LT 803 Only**), or the LVP
FOR REVERSE OSMOSIS WATER MAKER No.
1 and LVP FOR REVERSE OSMOSIS WATER
MAKER No. 2 circuit breakers (**All Other Ves-
sels**) at 440V power panel No. 5.
CLOSE, lock out, and tag out (FM 55-502) valve
RO-V-7.

CHARCOAL FILTER ELEMENT REPLACE
DISASSEMBLY

1. Grasp and slowly rotate the applicable filter bowl (figure 1, item 1) counterclockwise until it separates from the lid (figure 1, item 2).
2. Remove and discard the O-ring (figure 1, item 3).
3. Remove and discard the carbon briquette (filter element) (figure 1, item 4).
4. Remove all debris and foreign matter from the filter bowl (figure 1, item 1).
5. Thoroughly clean the lid (figure 1, item 2) and filter bowl (figure 1, item 1) using fresh water and clean rags.

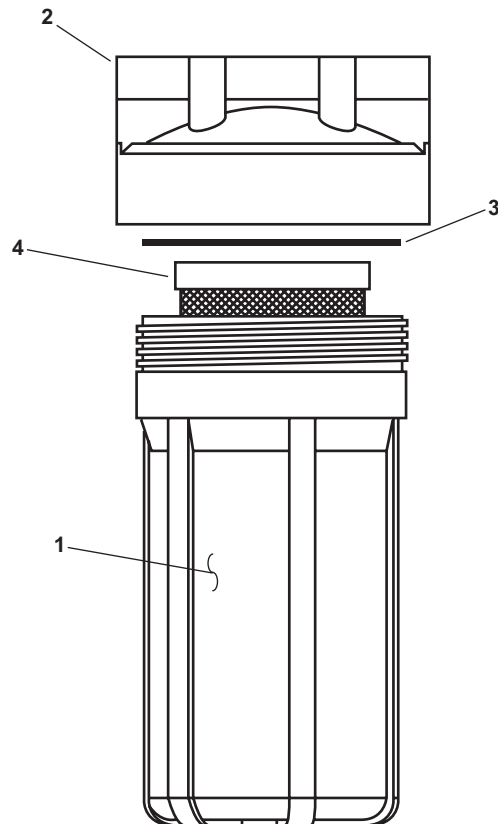

Figure 1. Charcoal Filter Assembly

ASSEMBLY

1. Place the new carbon briquette (filter element) (figure 1, item 4) into the filter bowl (figure 1, item 1).
2. Lubricate the new O-ring (figure 1, item 3) with silicone lubricant, and install it on the filter bowl (figure 1, item 1).
3. Position the filter bowl (figure 1, item 1) in contact with the lid (figure 1, item 2), and tighten until snug.
4. Remove the lockouts and tagouts (FM 55-502).
5. Perform ROWPU fresh water flush (WP 0005 00).
6. Inspect the charcoal filter for leaks.
7. Return the equipment to the desired readiness condition.

END OF WORK PACKAGE

Chapter 7

Direct Support Maintenance Instructions for Reverse Osmosis Water Purification Unit Inland and Coastal Large Tug (LT)

**DIRECT SUPPORT MAINTENANCE
REVERSE OSMOSIS WATER PURIFICATION UNIT FOR
INLAND AND COASTAL LARGE TUG (LT)
REVERSE OSMOSIS WATER PURIFICATION UNIT, REPAIR**

INITIAL SETUP:**Tools and Special Tools:**

Tool Kit, General Mechanic's (Item 1, Table 2, WP 0031 00)
 Tool Kit, Electrician's (Item 2, Table 2, WP 0031 00)
 Multimeter (Item 3, Table 2, WP 0031 00)
 Brush, Bottle and Buret (Item 11, Table 2, WP 0031 00)

Materials/Parts:

Tag, Danger (Item 17, Table 1, WP 0035 00)
 Tape, Antiseizing (Item 18, Table 1, WP 0035 00)

References:

FM 55-502
 WP 0005 00
 WP 0031 00
 WP 0035 00

Equipment Conditions:

CLOSE, lock out, and tag out (FM 55-502) valve RO-V-9.
 Set to OFF, lock out, and tag out (FM 55-502) the FWF PUMP circuit breaker at the 24 VDC control panel.

Personnel Required:

Two Watercraft Engineers, 88L

REPLACE SALINITY PROBE**REMOVAL**

Replace or repair components only after the affected circuit has been secured, locked out, and tagged out. Performing replacement with the circuit energized may result in serious injury or death.

1. Shut down the applicable Reverse Osmosis Water Purification Unit (ROWPU) (WP 0005 00).
2. At 440V power panel No. 5, set to OFF, lock out, and tag out (FM 55-502) the applicable circuit breaker as shown in table 1.
3. At the 24 Vdc control panel, lock out, and tag out (FM 55-502) the applicable ROWPU circuit breaker as shown in table 1.
4. CLOSE, lock out, and tag out (FM 55-502) the applicable inlet sea water supply valve as shown in table 1.

Table 1. ROWPU Lockout/Tagout Guide

ROWPU	Power Panel 5 Breaker	Inlet Sea Water Valve	Brine Discharge Valve	24 Vdc Breaker
1	REVERSE OSMOSIS WATER MAKER No. 1 (LT 803 Only) LVP FOR REVERSE OSMOSIS WATER MAKER No. 1 (All Other Vessels)	RO-V-1-1	RO-V-1-2	RO#1
2	REVERSE OSMOSIS WATER MAKER No. 2 (LT 803 Only) LVP FOR REVERSE OSMOSIS WATER MAKER No. 2 (All Other Vessels)	RO-V-2-1	RO-V-2-2	RO#2

- On the applicable system controller, loosen the two captive screws (figure 1, item 1) and open the front panel.

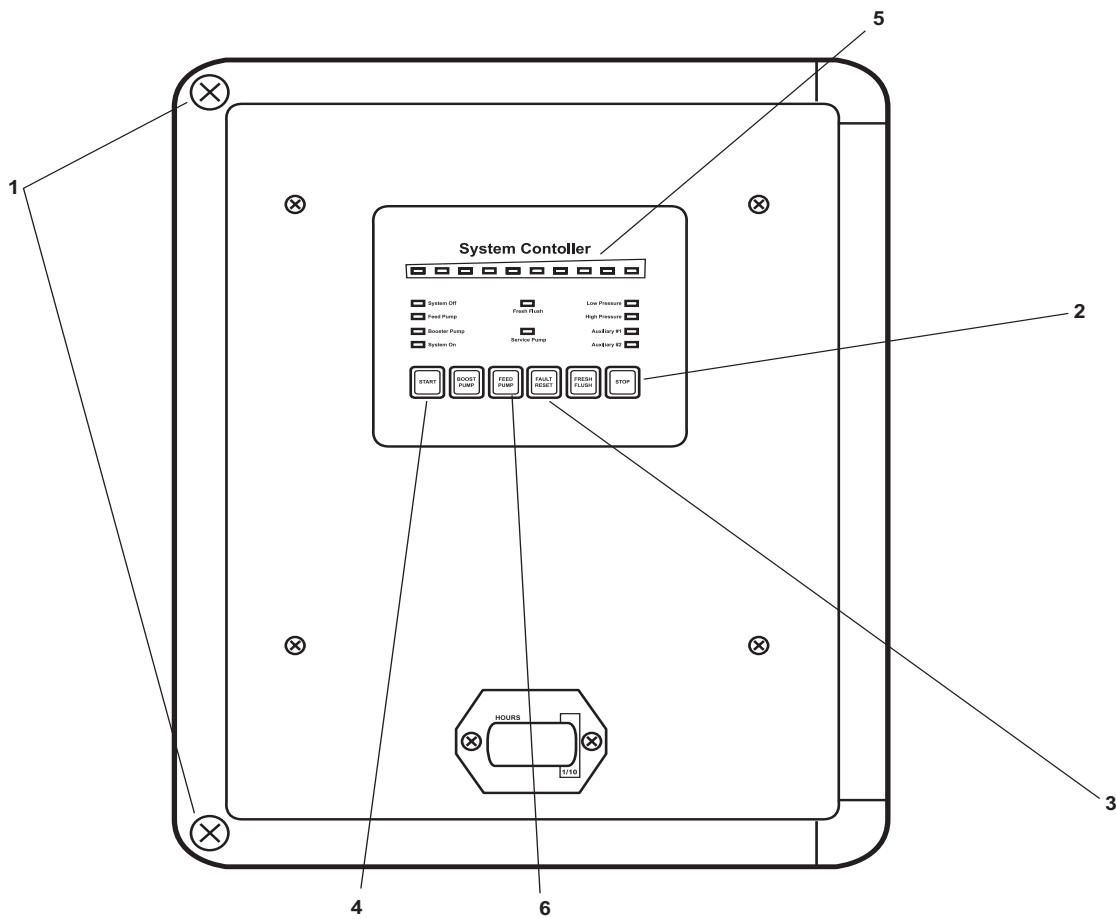

Figure 1. ROWPU System Controller Exterior



Take great care when working around electrical equipment. Contact between unprotected body parts and electrical conductors can cause serious injury or death. Do not wear jewelry or other conductive items while servicing energized electrical equipment. Failure to comply with these precautions can cause serious injury or death.

6. Inside the applicable system controller, take voltage readings with a multimeter, measuring across connection points L1, L2, and L3 (figure 2, item 1), and across the INPUT 24VDC terminals (figure 2, item 2). Ensure that all electrical circuits are deenergized. If voltage is present, verify that the correct circuit breakers are set to OFF, locked out, and tagged out (FM 55-502). If no voltage is present, continue with the procedure.
7. Inside the system controller, label and disconnect the three electrical leads (figure 3, item 1) that connect the salinity probe to the system controller.
8. Remove the wiring from the system controller.
9. Unscrew the salinity probe (figure 4, item 1) and remove it from the tee fitting (figure 4, item 2).

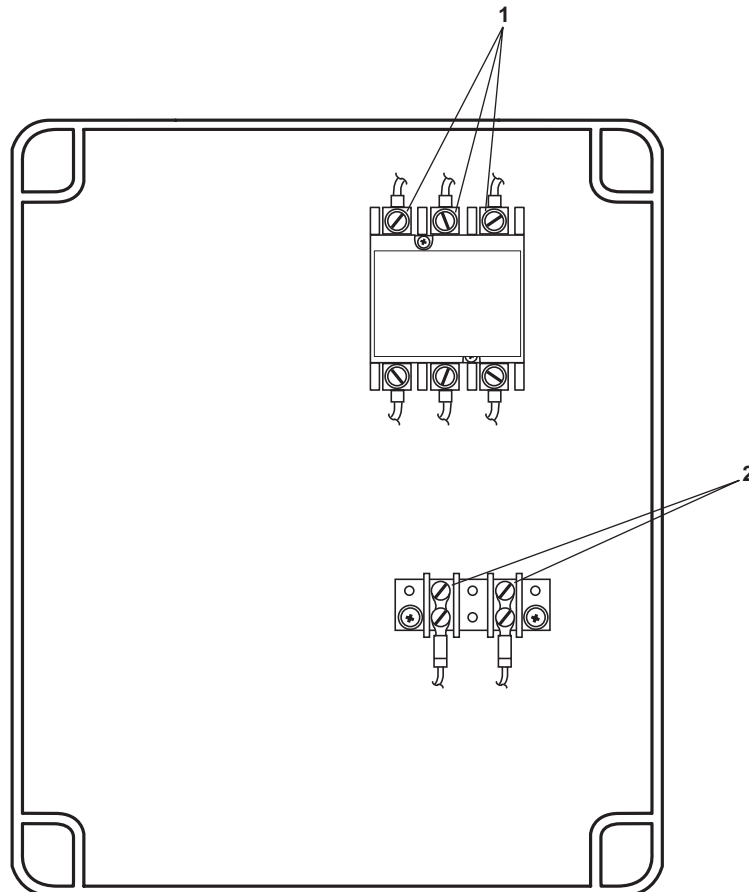

Figure 2. System Controller Terminal Boards

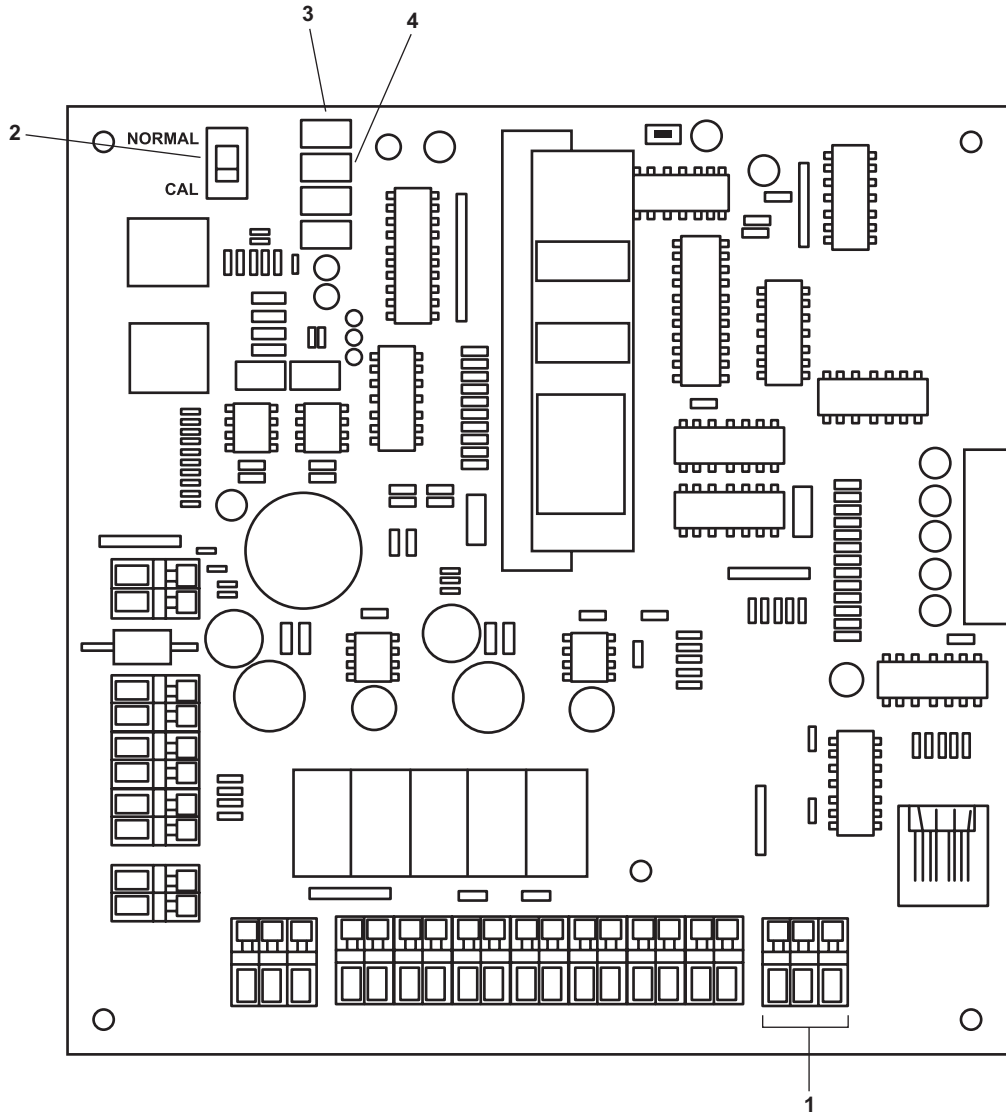

Figure 3. System Controller Motherboard and Connections

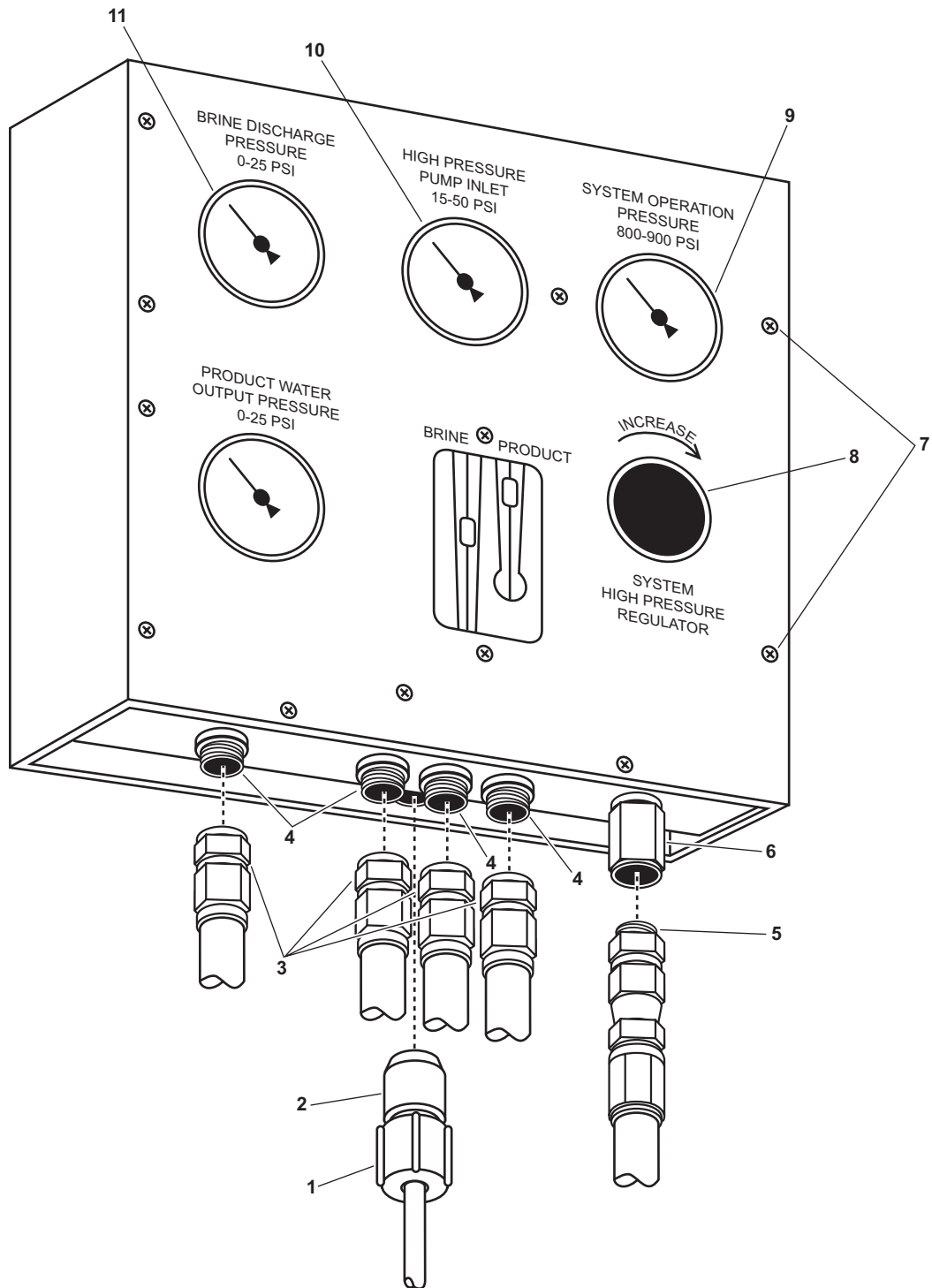

Figure 4. ROWPU Flow Control Panel

INSTALLATION

1. Place four wraps of antiseizing tape on the male threads of the salinity probe (figure 4, item 1).

CAUTION

The salinity probe must be installed hand tight only. Do not use tools to tighten the salinity probe. Over tightening will lead to equipment failure.

2. Install the salinity probe (figure 4, item 1) on the tee fitting (figure 4, item 2). Hand tighten only, using no tools.
3. Install the salinity probe electrical wiring using the labels from step 7 of Removal as a guide.
4. Close the system controller and tighten the two captive screws (figure 1, item 1).
5. Perform the Follow-On Service procedure at the end of this work package.

CLEAN SALINITY PROBE

1. Perform the Replace Salinity Probe Removal procedure contained in this work package.
2. Clean the salinity probe electrodes with a bottle and buret brush and clean fresh water. Remove any accumulated debris.
3. Perform the Replace Salinity Probe Installation procedure contained in this work package.

CALIBRATE SALINITY PROBE

1. On the applicable system controller, push the STOP switch (figure 1, item 2).
2. On the system controller, loosen the two captive screws (figure 1, item 1) and open the front panel.



Take great care when working around electrical equipment. Contact between unprotected body parts and electrical conductors can cause serious injury or death. Do not wear jewelry or other conductive items while servicing energized electrical equipment. Failure to comply with these precautions can cause serious injury or death.

3. Inside the system controller, place the normal/calibrate slide switch (figure 3, item 2) in the CAL position.
4. On the system controller, press the FAULT RESET switch (figure 1, item 3).
5. Press the START switch (figure 1, item 4) and observe the level indicated on the SALINITY METER (figure 1, item 5).
6. Rotate the salinity meter potentiometer adjustment screw (figure 3, item 3) until the SALINITY METER (figure 1, item 5) on the system controller reads full scale with the red LED flickering on and off (1000 ppm).
7. Press the STOP switch (figure 1, item 2).

8. Press the FEED PUMP switch (figure 1, item 6) and observe the level indicated on the SALINITY METER (figure 1, item 5).
9. Inside the system controller, rotate the 3-way trip point potentiometer adjustment screw (figure 3, item 4) until the SALINITY METER (figure 1, item 5) reads full scale with the red LED flickering on and off (1000 ppm).
10. On the system controller, press the STOP switch (figure 1, item 2).



Take great care when working around electrical equipment. Contact between unprotected body parts and electrical conductors can cause serious injury or death. Do not wear jewelry or other conductive items while servicing energized electrical equipment. Failure to comply with these precautions can cause serious injury or death.

11. Place the normal/calibrate slide switch (figure 3, item 2) in the NORMAL position.
12. Close the system controller door and tighten the two captive screws (figure 1, item 1).
13. Press the FAULT RESET switch (figure 1, item 3).
14. Perform the Follow-On Service procedure at the end of this work package.

REPLACE PRODUCT FLOW METER

REMOVAL

1. Shut down the applicable ROWPU (WP 0005 00).
2. At 440V power panel No. 5, set to OFF, lock out and tag out (FM 55-502) the applicable ROWPU circuit breaker as shown in table 1.
3. At the 24 Vdc control panel, lock out and tag out (FM 55-502) the applicable circuit breaker as shown in table 1.
4. CLOSE, lock out, and tag out (FM 55-502) the applicable inlet sea water supply valve as shown in table 1.
5. Disconnect and free the stainless steel piping (figure 4, item 3) from the fittings (figure 4, item 4).
6. Disconnect and free the outlet hose (figure 4, item 5) from its fitting (figure 4, item 6).
7. On the flow control panel, loosen the two captive screws (figure 4, item 7), and open the flow control panel.
8. Remove the top access screw (figure 5, item 1) to the PRODUCT flow meter glass tube (figure 5, item 2).
9. Remove the guide rod (figure 5, item 3) from the PRODUCT flow meter glass tube (figure 5, item 2).
10. Remove the PRODUCT flow meter glass tube (figure 5, item 2).
11. Remove the float (figure 5, item 4), bumpers (figure 5, item 5), and tube stops (figure 5, item 6) from the PRODUCT flow meter glass tube (figure 5, item 2).

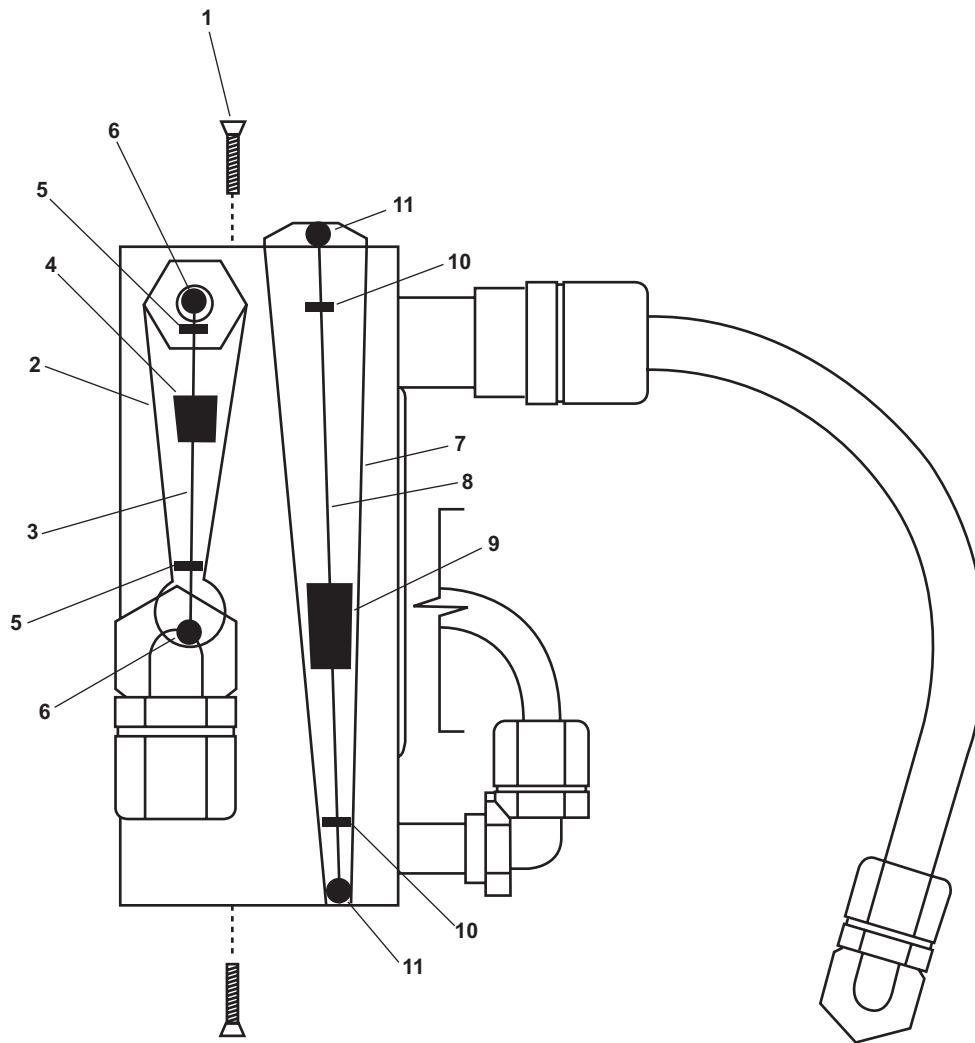

Figure 5. Product Water and Brine Flow Meters (Rear View)

INSTALLATION

1. Gently install the float (figure 5, item 4) on the guide rod (figure 5, item 3).
2. Gently install the guide rod (figure 5, item 3) and float (figure 5, item 4) in the PRODUCT flow meter glass tube (figure 5, item 2).
3. Install the bumpers (figure 5, item 5) and tube stops (figure 5, item 6) on the glass tube PRODUCT flow meter glass tube (figure 5, item 2).
4. Position the assembled PRODUCT flow meter in the applicable flow control panel.
5. Install the top access screw (figure 5, item 1).
6. Close the flow control panel and tighten the two captive screws (figure 4, item 7).
7. Install the stainless steel piping (figure 4, item 3) and outlet hose (figure 4, item 5) to their respective fittings (figure 4, items 4 and 6).
8. Perform the Follow-On Service procedure at the end of this work package.

CLEAN PRODUCT FLOW METER

1. Perform the Replace PRODUCT Flow Meter Removal procedure contained in this work package.
2. Thoroughly clean the interior of the PRODUCT flow meter glass tube (figure 5, item 2) using clean hot water and a small bottle and buret brush.
3. Perform the Replace PRODUCT Flow Meter Installation procedure contained in this work package.

REPLACE BRINE FLOW METER**REMOVAL**

1. Shut down the applicable ROWPU (WP 0005 00).
2. At 440V power panel No. 5, set to OFF, lock out, and tag out (FM 55-502) the applicable circuit breaker as shown in table 1.
3. At the 24 Vdc control panel, set to OFF, lock out, and tag out (FM 55-502) the applicable circuit breaker as shown in table 1.
4. CLOSE, lock out, and tag out (FM 55-502) the applicable sea water supply valve as shown in table 1.
5. Disconnect and free the stainless steel piping (figure 4, item 3) from the fittings (figure 4, item 4).
6. Disconnect and free the outlet hose (figure 4, item 5) from its fitting (figure 4, item 6).
7. Loosen the two captive screws (figure 4, item 7) and open the applicable flow control panel.
8. Remove the top access screw (figure 5, item 1) to the BRINE flow meter glass tube (figure 5, item 7).
9. Remove the guide rod (figure 5, item 8) from the BRINE flow meter glass tube (figure 5, item 7).
10. Remove the BRINE flow meter glass tube (figure 5, item 7).
11. Remove the float (figure 5, item 9), bumpers (figure 5, item 10), and tube stops (figure 5, item 11) from the BRINE flow meter glass tube (figure 5, item 7).

INSTALLATION

1. Gently install the float (figure 5, item 9) on the guide rod (figure 5, item 8).
2. Gently install the guide rod (figure 5, item 8) and float (figure 5, item 9) in the BRINE flow meter glass tube (figure 5, item 7).
3. Install the bumpers (figure 5, item 10) and tube stops (figure 5, item 11) on the BRINE flow meter glass tube (figure 5, item 7).
4. Position the assembled BRINE flow meter glass tube (figure 5, item 7) in the flow control panel.
5. Install the top access screw (figure 5, item 1).
6. Close the indicator panel and tighten the two captive screws (figure 4, item 7).
7. Install the stainless steel piping (figure 4, item 3) and outlet hose (figure 4, item 5) to their respective fittings (figure 4, items 4 and 6).
8. Perform the Follow-On Service procedure at the end of this work package.

CLEAN BRINE FLOW METER

1. Perform the Replace BRINE Flow Meter Removal procedure contained in this work package.
2. Thoroughly clean the interior of the BRINE flow meter glass tube (figure 5, item 7) using clean hot water and a small bottle and buret brush.
3. Perform the Replace BRINE Flow Meter Installation procedure contained in this work package.

ADJUST HIGH PRESSURE CUTOFF SWITCH

1. On the applicable ROWPU indicator panel, fully open the SYSTEM HIGH PRESSURE REGULATOR (figure 4, item 8).
2. On the applicable system controller, press the START switch (figure 1, item 4)
3. Slowly increase system operating pressure by CLOSING the SYSTEM HIGH PRESSURE REGULATOR (figure 4, item 8) until the SYSTEM OPERATION PRESSURE gauge (figure 4, item 9) indicates 950 PSI (65.5 bar).
4. If the system shuts down before reaching 900 PSI (62.1 bar), go to step 8.
5. If the applicable ROWPU did not shut down, decrease system operation pressure to 900 PSI (62.1 bar).

NOTE

Access to the high pressure cutoff switch adjustment screw is gained from the top of the flow control panel. It is not necessary to open the flow control panel to gain access to the adjustment screw.

6. Rotate the high pressure cutoff switch adjustment screw (figure 6, item 1) on top of the high pressure cutout switch (figure 6, item 2) no more than 1/8th of a turn counterclockwise.

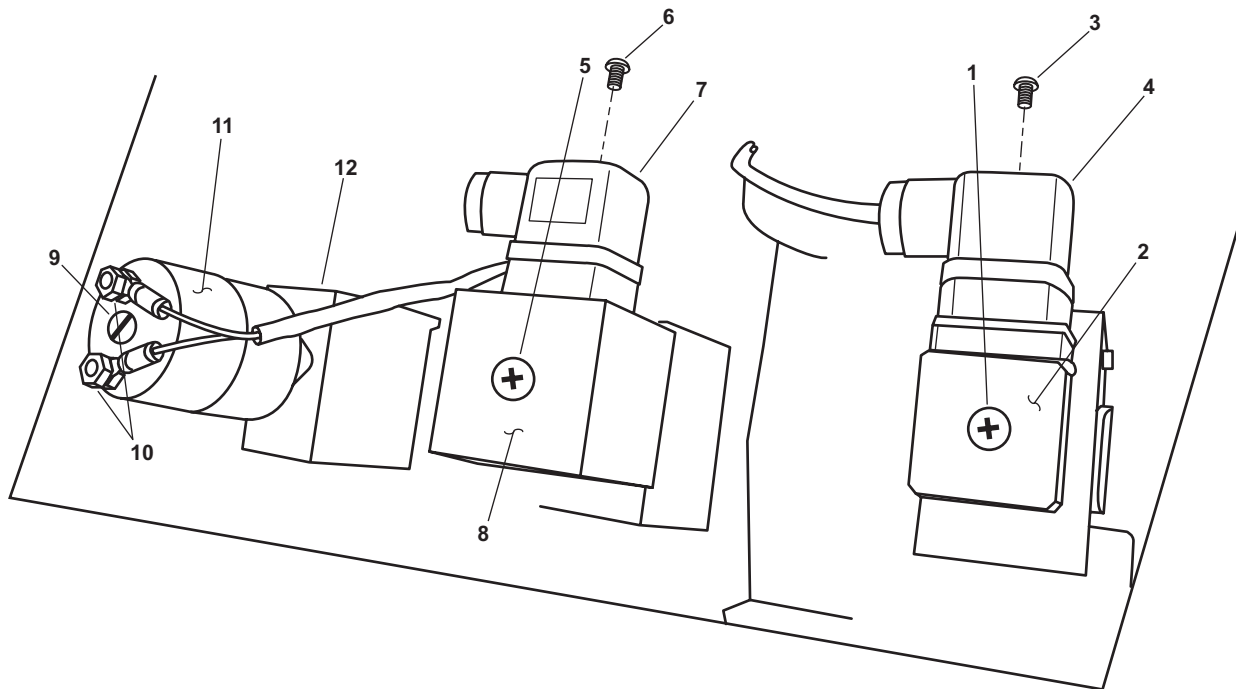

Figure 6. Flow Control Panel, Top View

7. Repeat step 6 until the applicable ROWPU shuts down at a pressure between 900 PSI (62.1 bar) and 950 PSI (65.5 bar), then go to step 9.
8. If the system shuts down before reaching 900 PSI (62.1 bar), repeat the following actions until the applicable ROWPU shuts down between 900 PSI (62.1 bar) and 950 PSI (65.5 bar):

NOTE

Access to the high pressure cutoff switch adjustment screw is gained from the top of the flow control panel. It is not necessary to open the flow control panel to gain access to the adjustment screw.

- a. Rotate the high pressure cutoff switch adjustment screw (figure 6, item 1) clockwise no more than 1/8th of a turn.
 - b. Fully open the SYSTEM HIGH PRESSURE REGULATOR (figure 4, item 8).
 - c. Press the FAULT RESET switch (figure 1, item 3).
 - d. Press the START switch (figure 1, item 4).
 - e. Slowly CLOSE the SYSTEM HIGH PRESSURE REGULATOR (figure 4, item 8) until the SYSTEM OPERATION PRESSURE gauge (figure 4, item 9) indicates between 900 PSI (62.1 bar) and 950 PSI (65.5 bar).
9. Press the STOP switch (figure 1, item 2).
 10. Perform the Follow-On Service procedure at the end of this work package.

REPLACE HIGH PRESSURE CUTOFF SWITCH

REMOVAL

1. Shut down the applicable ROWPU (WP 0005 00).
2. At the 440V power panel No. 5, set to OFF, lock out, and tag out (FM 55-502) the applicable circuit breaker as shown in table 1.
3. At the 24 Vdc control panel, set to OFF, lock out, and tag out (FM 55-502) the applicable circuit breaker as shown in table 1.
4. CLOSE, lock out, and tag out (FM 55-502) the applicable inlet sea water supply valve as shown in table 1.

NOTE

Access to the high pressure cutoff switch is gained from the rear of the flow control panel. It is not necessary to open the flow control panel to replace the switch.

5. Remove the screw (figure 6, item 3) that secures the wire plug (figure 6, item 4) to the high pressure cutoff switch (figure 6, item 2).
6. Pull the wire plug (figure 6, item 4) straight off of the high pressure cutoff switch (figure 6, item 2).
7. Unscrew the high pressure cutoff switch (figure 6, item 2), and remove it from the SYSTEM OPERATION PRESSURE gauge (figure 4, item 9).

INSTALLATION

1. Place four wraps of antiseizing tape on the male threads of the high pressure cutoff switch (figure 6, item 2).

 CAUTION

The high pressure cutoff switch must be installed hand tight only. Do not use tools to tighten the high pressure cutoff switch. Over tightening will lead to equipment failure.

2. Thread the high pressure cutoff switch (figure 6, item 2) into the fitting on the back of the SYSTEM OPERATION PRESSURE gauge (figure 4, item 9). Tighten hand tight only, using no tools.
3. Slide the wire plug (figure 6, item 4) into place on the high pressure cutoff switch (figure 6, item 2) and secure it in place with the screw (figure 6, item 3).
4. Perform the Follow-On Service procedure at the end of this work package.

ADJUST LOW PRESSURE CUTOFF SWITCH

1. Fully OPEN the SYSTEM HIGH PRESSURE REGULATOR (figure 4, item 8).
2. At the system controller, press the FAULT RESET switch (figure 1, item 3).
3. On the applicable system controller, press the START switch (figure 1, item 4) and observe the HIGH PRESSURE PUMP INLET pressure gauge (figure 4, item 10).
4. Slowly throttle the applicable inlet sea water supply valve (table 1) in the CLOSED position until the HIGH PRESSURE PUMP INLET gauge (figure 4, item 10) indicates 15 PSI (1.0 bar).
5. If the ROWPU did not shut down before reaching 15 PSI (1.0 bar), continue to step 6. If the ROWPU did shut down before reaching 15 PSI (1.0 bar), go to step 7.
6. Adjust the low pressure cutoff to a higher set point as follows:
 - a. Verify that the ROWPU is still running and that the HIGH PRESSURE PUMP INLET pressure gauge (figure 4, item 10) indicates 15 PSI (1.0 bar).

NOTE

Access to the low pressure cutoff switch adjustment screw is gained from the top of the flow control panel. It is not necessary to open the flow control panel to gain access to the adjustment screw.

- b. Rotate the low pressure cutoff switch adjustment screw (figure 6, item 5) a maximum of 1/8th of a turn clockwise.
- c. Repeat steps 6a and 6b until the ROWPU shuts down when the HIGH PRESSURE PUMP INLET pressure gauge (figure 4, item 10) indicates between 15 PSI (1.0 bar) and 16 PSI (1.1 bar).
- d. Go to step 8.

7. Adjust the low pressure cutoff to a lower setting as follows:

NOTE

Access to the low pressure cutoff switch adjustment screw is gained from the top of the flow control panel. It is not necessary to open the flow control panel to gain access to the adjustment screw.

- a. Rotate the low pressure cutoff switch adjustment screw (figure 6, item 5) a maximum of 1/8th of a turn counterclockwise.
 - b. Fully OPEN the applicable inlet sea water supply valve as shown in table 1.
 - c. Press the FAULT RESET switch (figure 1, item 3).
 - d. Press the START switch (figure 1, item 4).
 - e. Slowly throttle the applicable inlet sea water supply valve (table 1) in the CLOSED position until the HIGH PRESSURE PUMP INLET pressure gauge (figure 4, item 10) indicates between 15 PSI (1.0 bar) and 16 PSI (1.1 bar).
 - f. Repeat steps 7a - 7e until the ROWPU shuts down automatically when the applicable HIGH PRESSURE PUMP INLET pressure gauge (figure 4, item 10) indicates between 15 PSI (1.0 bar) and 16 PSI (1.1 bar).
8. At the applicable system controller, press the STOP switch (figure 1, item 2).
 9. Perform the Follow-On Service procedure at the end of this work package.

REPLACE LOW PRESSURE CUTOFF SWITCH

REMOVAL

1. Shut down the applicable ROWPU (WP 0005 00).
2. At 440V power panel No. 5, set to OFF, lock out, and tag out (FM 55-502) the applicable circuit breaker as shown in table 1.
3. At the 24 Vdc control panel, set to OFF, lock out, and tag out (FM 55-502) the applicable circuit breaker as shown in table 1.
4. CLOSE, lock out, and tag out (FM 55-502) the applicable sea water supply valve as shown in table 1.

NOTE

Access to the low pressure cutoff switch is gained from the rear of the flow control panel. It is not necessary to open the flow control panel to replace the switch.

5. Remove the screw (figure 6, item 6) that secures the wire plug (figure 6, item 7) to the low pressure cutoff switch (figure 6, item 8).
6. Pull the wire plug (figure 6, item 7) straight off the low pressure cutoff switch (figure 6, item 8).
7. Unscrew the low pressure cutoff switch (figure 6, item 8) and remove it from the HIGH PRESSURE PUMP INLET pressure gauge (figure 4, item 10).

INSTALLATION

1. Place four wraps of antiseizing tape on the male threads of the low pressure cutoff switch (figure 6, item 8).

 CAUTION

The low pressure cutoff switch must be installed hand tight only. Do not use tools to tighten the high pressure cutoff switch. Over tightening will lead to equipment failure.

2. Thread the low pressure cutoff switch (figure 6, item 8) into the fitting on the back of the HIGH PRESSURE PUMP INLET gauge (figure 4, item 10). Tighten hand tight only, using no tools.
3. Slide the wire plug (figure 6, item 7) into place on the low pressure cutoff switch (figure 6, item 8) and secure it in place with the screw (figure 6, item 6).
4. Perform the Follow-On Service procedure at the end of this work package.

ADJUST VALVE MISALIGNMENT SHUTDOWN SWITCH

1. At applicable the system controller, push the STOP switch (figure 1, item 2).
2. At the applicable flow control panel, place the SYSTEM HIGH PRESSURE REGULATOR valve (figure 4, item 8) in the fully OPEN position.
3. Press the FAULT RESET switch (figure 1, item 3).
4. Press the START switch (figure 1, item 4) and observe the pressure indicated on the BRINE DISCHARGE PRESSURE gauge (figure 4, item 11) at the flow control panel.

 CAUTION

Take great care when CLOSING the brine discharge valve during system operation. Exceeding a brine discharge pressure of 25 PSI (1.7 bar) could damage the reverse osmosis membranes.

5. Slowly, and without exceeding 25 PSI (1.7 bar) brine discharge pressure, throttle the applicable brine discharge valve (table 1) in the CLOSED position until the BRINE DISCHARGE PRESSURE gauge (figure 4, item 11) indicates 24 PSI (1.6 bar).
6. If the ROWPU shuts down before reaching 24 PSI (1.6 bar), continue to step 7. If the ROWPU did not shut down before reaching 24 PSI (1.6 bar), go to step 8.
7. Adjust the brine discharge pressure cutoff to a higher setting as follows:

NOTE

Access to the valve misalignment shutdown switch adjustment screw is gained from the top of the flow control panel. It is not necessary to open the flow control panel to gain access to the adjustment screw.

- a. Rotate the brine valve misalignment shutdown switch adjustment screw (figure 6, item 9) a maximum of 1/8th of a turn clockwise.
- b. Fully OPEN the applicable brine pressure discharge valve (table 1).

- c. Press the FAULT RESET switch (figure 1, item 3).
- d. Press the START switch (figure 1, item 4).

CAUTION

Take great care when CLOSING the brine discharge valve during system operation. Exceeding a brine discharge pressure of 25 PSI (1.7 bar) could damage the reverse osmosis membranes.

- e. Slowly, and without exceeding 25 PSI (1.7 bar) brine discharge pressure, throttle the applicable brine discharge valve (table 1) in the CLOSED position until the BRINE DISCHARGE PRESSURE gauge (figure 4, item 11) on the applicable flow control panel indicates 24 PSI (1.6 bar).
 - f. Repeat steps 7a - 7e until the applicable ROWPU shuts down at 24 PSI (1.6 bar) to 25 PSI (1.7 bar).
 - g. Go to step 9.
8. Adjust the applicable brine discharge pressure cutoff to a lower setting as follows:

NOTE

Access to the valve misalignment shutdown switch adjustment screw is gained from the top of the flow control panel. It is not necessary to open the flow control panel to gain access to the adjustment screw.

- a. Rotate the applicable brine valve misalignment shutdown switch adjustment screw (figure 6, item 9) a maximum of 1/8th of a turn counterclockwise.
 - b. Verify that the BRINE DISCHARGE PRESSURE gauge (figure 4, item 11) reads 24 PSI (1.6 bar).
 - c. Verify that the ROWPU is still running.
 - d. Repeat steps 8a - 8c until the applicable ROWPU shuts down between 24 PSI (1.6 bar) and 25 PSI (1.7 bar) as indicated by the BRINE DISCHARGE PRESSURE gauge (figure 4, item 11).
9. Press the FAULT RESET switch (figure 1, item 3) on the applicable system controller.
10. Perform the Follow-On Service procedure at the end of this work package.

REPLACE VALVE MISALIGNMENT SHUTDOWN SWITCH

REMOVAL

1. Shut down the applicable ROWPU (WP 0005 00).
2. At 440V power panel No. 5, set to OFF, lock out, and tag out (FM 55-502) the applicable circuit breaker as shown in table 1.
3. At the 24 Vdc control panel, set to OFF, lock out, and tag out (FM 55-502) the applicable circuit breaker as shown in table 1.
4. CLOSE, lock out, and tag out (FM 55-502) the applicable inlet sea water supply valve as shown in table 1.

NOTE

Access to the valve misalignment shutdown switch can be gained from the rear of the flow control panel. It is not necessary to open the flow control panel to gain access.

5. Label and disconnect the wiring (figure 6, item 10) from the valve misalignment shutdown switch (figure 6, item 11).
6. Unscrew the valve misalignment shutdown switch (figure 6, item 11) and remove it from the tee connection (figure 6, item 12).

INSTALLATION

1. Place four wraps of antiseizing tape on the male threads of the valve misalignment shutdown switch (figure 6, item 11).

 **CAUTION**

The valve misalignment shutdown switch must be installed hand tight only. Do not use tools to tighten the valve misalignment shutdown switch. Over tightening will lead to equipment failure.

2. Screw the valve misalignment shutdown switch (figure 6, item 11) into the tee connection (figure 6, item 12). Tighten hand tight only, using no tools.
3. Connect the wiring (figure 6, item 10) using the labels from step 5 of Removal as a guide.
4. Perform the Follow-On Service procedure at the end of this work package.

REPLACE FRESH WATER FLUSH DIVERTER VALVE**REMOVAL**

1. Shut down the applicable ROWPU (WP 0005 00).
2. At 440V power panel No. 5, set to OFF, lock out, and tag out (FM 55-502) the applicable circuit breaker as shown in table 1.
3. At the 24 Vdc control panel, set to OFF, lock out, and tag out (FM 55-502) the applicable circuit breaker as shown in table 1.
4. CLOSE, lock out, and tag out (FM 55-502) the applicable inlet sea water supply valve as shown in table 1.

NOTE

The fresh water flush diverter valves are located on the valve mount cross member below the respective system controller. Access to the fresh water flush diverter valves is gained from the front of the ROWPU system.

5. Remove the screw (figure 7, item 1) that secures the wire plug (figure 7, item 2) to the fresh water flush diverter valve (figure 7, item 3).
6. Disconnect the piping (figure 7, item 4) from the fresh water flush diverter valve (figure 7, item 3).
7. Remove the four screws (figure 7, item 5) and four flat washers (figure 7, item 6) that secure the fresh water flush diverter valve (figure 7, item 3) to its foundation.
8. Remove the pipe fittings (figure 7, item 7) from the fresh water flush diverter valve (figure 7, item 3). Retain the pipe fittings.

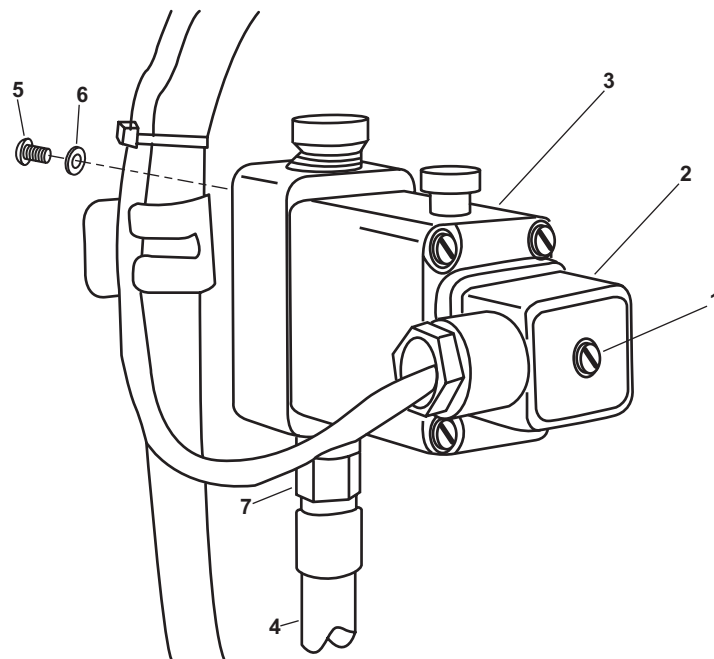

Figure 7. Fresh Water Flush Diverter Valve

INSTALLATION

1. Wrap the male threads of the pipe fittings (figure 7, item 7) with four wraps of antiseizing tape.
2. Thread the pipe fittings (figure 7, item 7) into place on the fresh water flush diverter valve (figure 7, item 3) and tighten snugly into place.
3. Position the fresh water flush diverter valve (figure 7, item 3) on its foundation and secure it in place with four screws (figure 7, item 5) and four flat washers (figure 7, item 6).
4. Connect the piping (figure 7, item 4) to the fresh water flush diverter valve (figure 7, item 3).
5. Slide the wire plug (figure 7, item 2) onto the fresh water flush diverter valve (figure 7, item 3) and secure it in place with the screw (figure 7, item 1).
6. Perform the Follow-On Service procedure at the end of this work package.

REPLACE PRODUCT WATER DIVERTER VALVE

REMOVAL

1. Shut down the applicable ROWPU (WP 0005 00).
2. At 440V power panel No. 5, set to OFF, lock out, and tag out (FM 55-502) the applicable circuit breaker as shown in table 1.
3. At the 24 Vdc control panel, set to OFF, lock out, and tag out (FM 55-502) the applicable circuit breaker as shown in table 1.

4. CLOSE, lock out, and tag out (FM 55-502) the applicable inlet sea water supply valve as shown in table 1.
5. Disconnect and free the stainless steel piping (figure 4, item 3) from the fittings (figure 4, item 4).
6. Disconnect and free the outlet hose (figure 4, item 5) from its fitting (figure 4, item 6).
7. On the flow control panel, loosen the two captive screws (figure 4, item 7) and open the flow control panel.
8. Remove the screw (figure 8, item 1) that secures the wire plug (figure 8, item 2) to the product water diverter valve (figure 8, item 3).
9. Pull the wire plug (figure 8, item 2) straight off of the product water diverter valve (figure 8, item 3).
10. Label and disconnect the tubing (figure 8, items 4, 5 and 6) from the product water diverter valve (figure 8, item 3).
11. Remove the four screws (figure 8, item 7) and four flat washers (figure 8, item 8) that secure the product water diverter valve (figure 8, item 3) to its foundation (figure 8, item 9).
12. Remove the pipe fittings (figure 8, item 10) from the product water diverter valve (figure 8, item 3). Retain the pipe fittings.

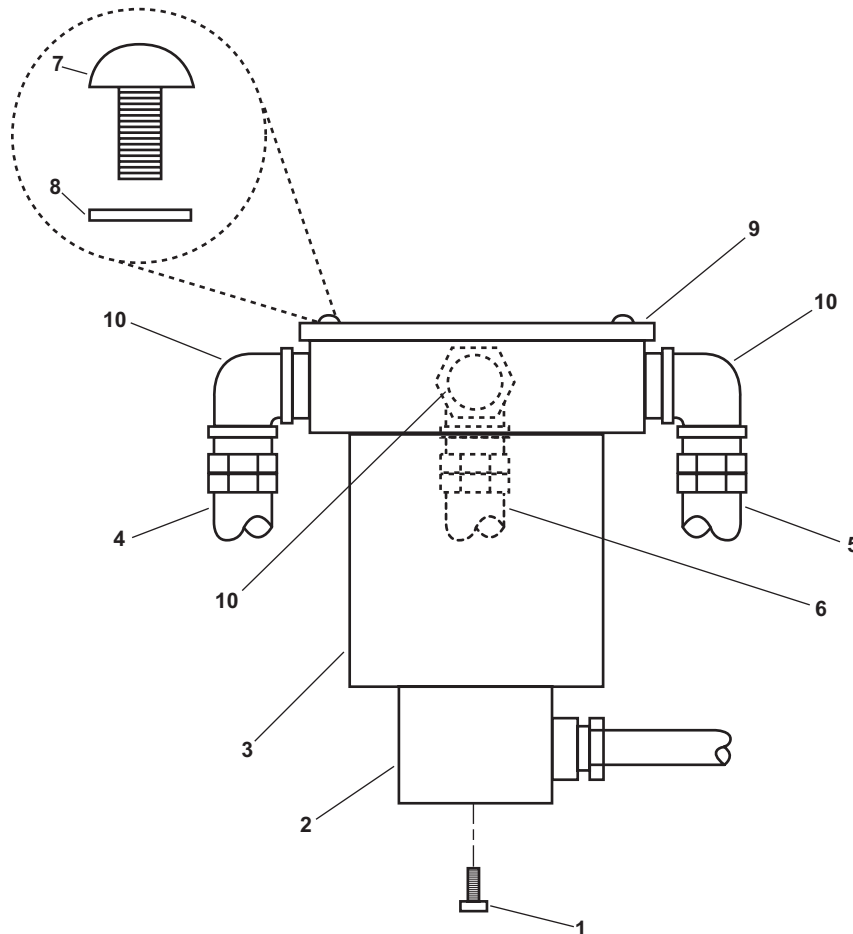

Figure 8. Product Water Diverter Valve

INSTALLATION

1. Wrap the male threads of the pipe fittings (figure 8, item 10) with four wraps of antiseizing tape.
2. Thread the pipe fittings (figure 8, item 10) into place on the product water diverter valve (figure 8, item 3) and tighten snugly into place.
3. Position the product water diverter valve (figure 8, item 3) on its foundation (figure 8, item 9) and secure it in place with four screws (figure 8, item 7) and four flat washers (figure 8, item 8).
4. Connect the tubing (figure 8, items 4, 5 and 6) to the product water diverter valve (figure 8, item 3).
5. Slide the wire plug (figure 8, item 2) onto the product water diverter valve (figure 8, item 3) and secure it in place with the screw (figure 8, item 1).
6. CLOSE the flow control panel and tighten the two captive screws (figure 4, item 7).
7. Perform the Follow-On Service procedure at the end of this work package.

FOLLOW-ON SERVICE

1. Remove lockouts and tagouts (FM 55-502).
2. Start up the applicable ROWPU (WP 0005 00) and check for proper system operation.
3. Check the ROWPU for any leaks.
4. If the salinity probe was removed or replaced, perform the Calibrate Salinity Probe procedure contained in this work package.
5. If the high pressure cutoff switch was removed or replaced, perform the Adjust High Pressure Switch Cutoff procedure contained in this work package.
6. If the low pressure cutoff switch was removed or replaced, perform the Adjust Low Pressure Cutoff Switch procedure contained in this work package.
7. If the valve misalignment shutdown switch was removed or replaced, perform the Adjust Valve Misalignment Shutdown Switch procedure contained in this work package.
8. Return the equipment to the desired readiness condition.

END OF WORK PACKAGE

**DIRECT SUPPORT MAINTENANCE
REVERSE OSMOSIS WATER PURIFICATION UNIT FOR
INLAND AND COASTAL LARGE TUG (LT)
PREFILTRATION SUBASSEMBLY, REPLACE**

INITIAL SETUP:

Tools and Special Tools:

Tool Kit, General Mechanic's (Item 1, Table 2, WP 0031 00)

Materials/Parts:

Lubricant, Silicone (Item 11, Table 1, WP 0035 00)
Rag, Wiping (Item 14, Table 1, WP 0035 00)
Tag, Danger (Item 17, Table 1, WP 0035 00)
Prefilter Assembly (Item 1, Figure 4 WP 0033 00)
Prefilter Assembly (Item 7, Figure 4 WP 0033 00)
O-Ring (Item 2, Figure 4, WP 0033 00)
O-Ring (Item 9, Figure 4, WP 0033 00)

Materials/Parts (continued):

Nut, Self Locking (Qty 4) (Item 17, Figure 4, WP 0033 00)
Filter Element (Item 5, Figure 4, WP 0033 00)
Filter Element (Item 10, Figure 4, WP 0033 00)

Personnel Required:

Two Watercraft Engineers, 88L

References:

FM 55-502
WP 0005 00
WP 0031 00
WP 0033 00
WP 0035 00

REMOVAL

1. Shut down the applicable Reverse Osmosis Water Purification Unit (ROWPU) (WP 0005 00).
2. CLOSE, lock out, and tag (FM 55-502) out the applicable inlet sea water supply valve as shown in table 1.
3. Perform Fresh Water Flush (WP 0005 00) for the applicable ROWPU.
4. Slowly, OPEN the filter bleed screw (figure 1, item 1) on top of the filter housing lid (figure 1, item 2).
5. Allow any pressure to vent, or any fluid to drain.
6. If applicable (table 1), remove the gauge (figure 1, item 3) from the filter housing lid (figure 1, item 2), and set aside.
7. Remove the inlet hose filter nut (figure 1, item 4) from the filter housing (figure 1, item 5).
8. Remove the outlet hose filter nut (figure 1, item 6) from the filter housing (figure 1, item 5).
9. Remove the four bolts (figure 1, item 7), eight flat washers (figure 1, item 8) and four self locking nuts (figure 1, item 9) that secure the filter housing (figure 1, item 5) in place. Discard the self locking nuts.
10. Remove the filter housing (figure 1, item 5).

Table 1. Filter Assembly Installation Guide

ROWPU	Specific Filter	Valve	Gauge Installed	Plug Installed
1	20-Micron Filter	RO-V-1-1	No	Yes
1	5-Micron Filter	RO-V-1-1	Yes	No
2	20-Micron Filter	RO-V-2-1	No	Yes
2	5-Micron Filter	RO-V-2-1	Yes	No

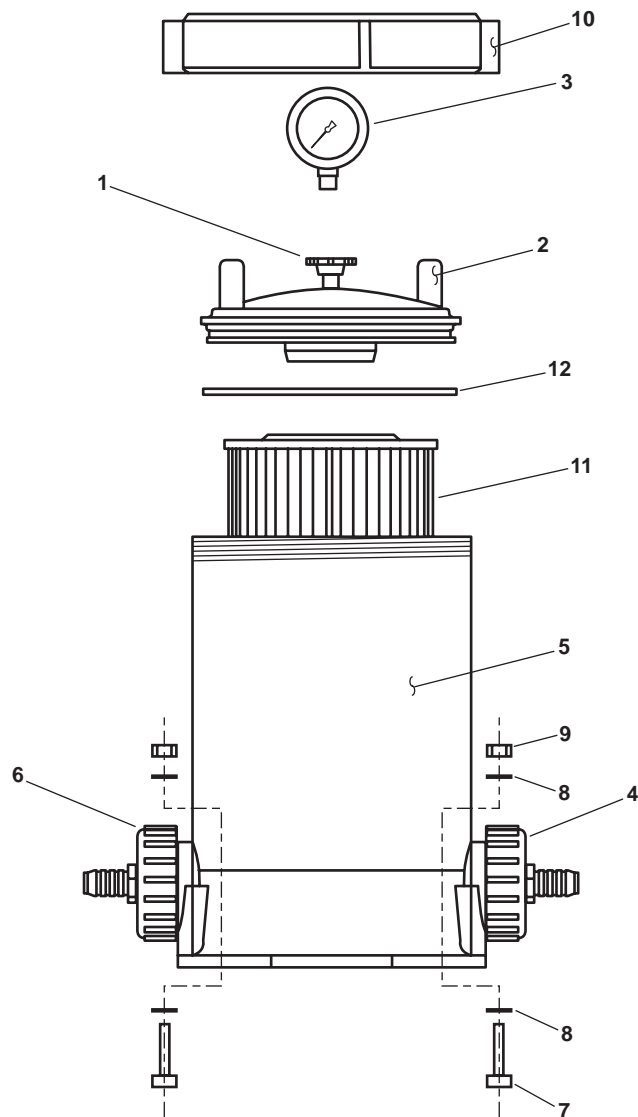

Figure 1. Filter Assembly

INSTALLATION

1. Secure the filter housing (figure 1, item 5) in place using four bolts (figure 1, item 7), eight flat washers (figure 1, item 8), and four new self locking nuts (figure 1, item 9).
2. Install the outlet hose filter nut (figure 1, item 6) to the filter housing (figure 1, item 5).
3. Install the inlet hose filter nut (figure 1, item 4) to the filter housing (figure 1, item 5).
4. If applicable (table 1), install the gauge (figure 1, item 3) to the filter housing lid (figure 1, item 2).
5. Unscrew the filter housing lid retaining ring (figure 1, item 10), and remove it from the filter housing (figure 1, item 5).
6. Remove the filter housing lid (figure 1, item 2) from the filter housing (figure 1, item 5).

7. Thoroughly clean the interior of the new filter housing (figure 1, item 5) with fresh water and clean rags.
8. Thoroughly clean the filter housing lid (figure 1, item 2) using fresh water and clean rags.
9. Install a new filter element (figure 1, item 11) in the filter housing (figure 1, item 5).
10. Lubricate the O-ring (figure 1, item 12) with silicone compound, and install it on the filter housing lid (figure 1, item 2).
11. Place the filter housing lid (figure 1, item 2) on top of the filter housing (figure 1, item 5).
12. Place the lid retaining ring (figure 1, item 10) in position over the filter housing lid (figure 1, item 2), and tighten until snug.
13. Remove the lockouts and tagouts (FM 55-502).
14. OPEN the bleed screw (figure 1, item 1) on the filter housing lid (figure 1, item 2).
15. Perform Fresh Water Flush (WP 0005 00) on the applicable ROWPU.
16. When the filter housing (figure 1, item 5) is full of water, as indicated by a solid stream of water flowing from the bleed screw (figure 1, item 1), CLOSE the bleed screw.
17. Check the filter housing and its connections for leaks.
18. Return the equipment to the desired readiness condition.

END OF WORK PACKAGE

**DIRECT SUPPORT MAINTENANCE
REVERSE OSMOSIS WATER PURIFICATION UNIT FOR
INLAND AND COASTAL LARGE TUG (LT)
HIGH PRESSURE PUMP, REPAIR**

INITIAL SETUP:**Tools and Special Tools:**

Tool Kit, Electrician's (Item 2, Table 2, WP 0031 00)
Torque Wrench, 0-600 IN-LB (Item 7, Table 2, WP 0031 00)
Slide Hammer, Packing Extraction (Item 8, Table 2, WP 0031 00)
Packing Extraction Socket (Collet) (Item 9, Table 2, WP 0031 00)
Tool, Seal Installation (Item 10, Table 2, WP 0031 00)

Materials/Parts:

Gloves, Chemical and Oil Protective (Item 3, Table 3, WP 0034 00)
Goggles, Industrial (Item 4, Table 3, WP 0034 00)
Isopropyl Alcohol (Item 10, Table 1, WP 0035 00)
Lubricant, Silicone (Item 11, Table 1, WP 0035 00)

Materials/Parts (continued):

Rag, Wiping (Item 14, Table 1, WP 0035 00)
Sealing Compound, Loctite 242 (Item 16, Table 1, WP 0035 00)
Parts Kit, Seal Replacement (Figure 5, WP 0033 00)

Personnel Required:

One Watercraft Engineer, 88L

References:

TB 43-0218
WP 0021 00
WP 0031 00
WP 0033 00
WP 0034 00
WP 0035 00

Equipment Conditions:

High pressure pump removed (WP 0021 00)

WARNING

Never reuse locking hardware. Reuse of locking hardware such as lockwashers, locking nuts, cotter pins, and lock wire can result in undetected loosening of fastening hardware causing catastrophic component failure resulting in death, injury, or damage to equipment. In accordance with TB 43-0218, ensure that all locking hardware is discarded upon removal and replaced with new.

REPLACE HIGH PRESSURE PUMP SEALS, VALVES, AND PLUNGER**DISASSEMBLY****NOTE**

Only one valve kit is required to replace all the valves in one pump. The valve O-rings, valve seats, valves, springs, and cages are all preassembled.

1. Unscrew and remove the six valve plugs (figure 1, item 1).
2. Remove the six valve plug O-rings (figure 1, item 2) and discard.
3. Pull to remove the six valve assemblies (figure 1, item 3) and discard.
4. Remove the six valve spacer O-rings (figure 1, item 4) and discard.

NOTE

The high pressure pump manifold is held in place by eight screws. The bottom row of four screws are 10 mm (0.4 in) longer than the top row of screws.

5. Loosen the top four manifold screws (figure 1, item 5) ¼ turn.
6. Loosen the four bottom manifold screws (figure 1, item 6) ¼ turn.
7. Hold the manifold (figure 1, item 7) in place, remove the four bottom manifold screws (figure 1, item 6), the four top manifold screws (figure 1, item 5) and eight flat washers (figure 1, item 8).

⚠ CAUTION

When separating the manifold from the crankcase, grasp it with both hands, and pull straight out. Do not apply any side, upward, or downward pressure on the manifold or damage could occur to the pump.

8. Pull the manifold (figure 1, item 7) straight out to separate it from the pump crankcase (figure 1, item 9).
9. Use a slide hammer/extraction collet to remove the six seal assemblies (figure 1, item 10) from the back of the manifold (figure 1, item 7).
10. Discard the seal assemblies (figure 1, item 10).

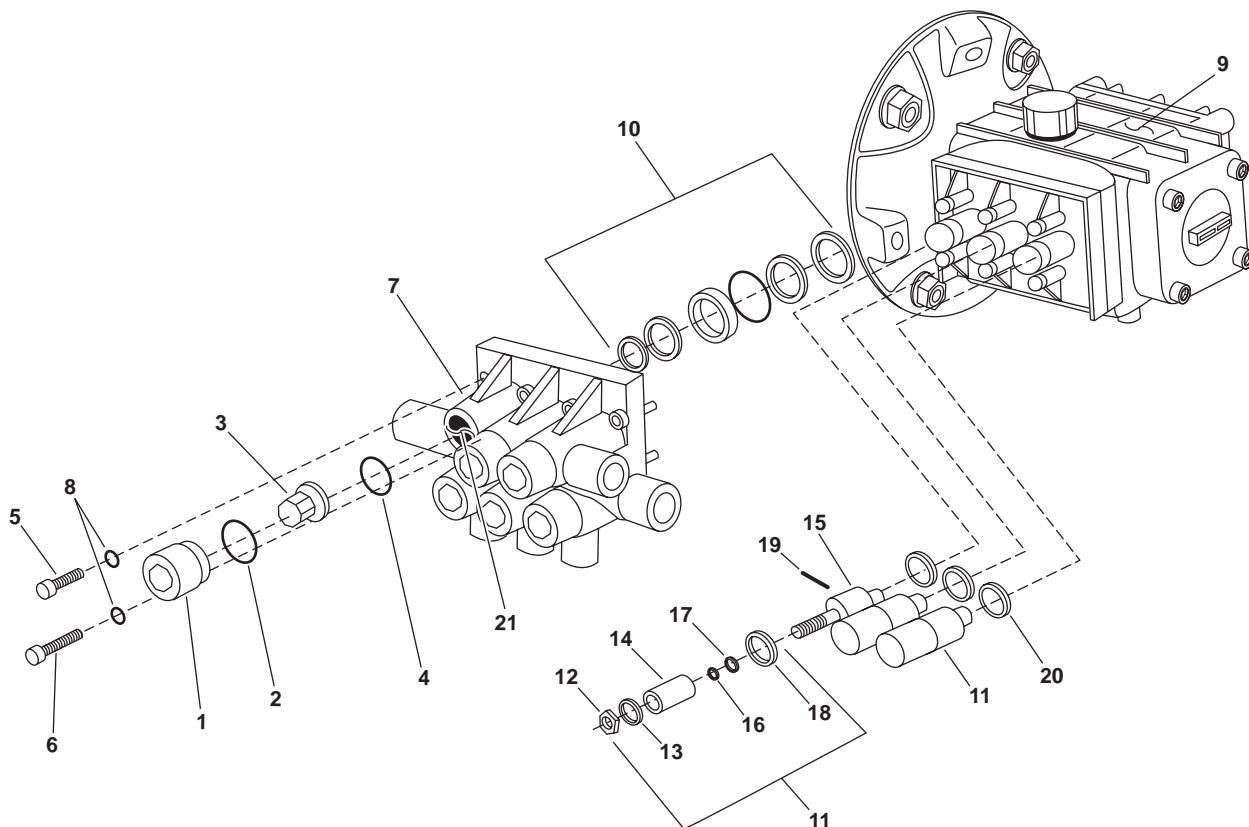

Figure 1. High Pressure Pump

11. Grasp and pull the three plunger assemblies (figure 1, item 11) to remove them from the crankcase (figure 1, item 9).
12. Disassemble each plunger assembly as follows:
 - a. Remove the plunger retaining nut (figure 1, item 12) and washer (figure 1, item 13).
 - b. Discard the washer (figure 1, item 13).
 - c. Twist the ceramic plunger (figure 1, item 14) either direction, and remove it from the plunger rod (figure 1, item 15) by pulling it straight off.
 - d. Discard the plunger (figure 1, item 14).
 - e. Remove and discard the plunger O-ring (figure 1, item 16) and anti-extrusion ring (figure 1, item 17).

WARNING

Do not allow hydraulic fluid, engine oil, or cleaning solvents to come in contact with unprotected skin or eyes. Prolonged skin contact can cause illness or injury. Eye contact can cause serious injury. Always wear chemical protective gloves and goggles when handling hydraulic fluid, engine oil, and cleaning solvents. Failure to follow these precautions can result in illness or serious injury.

Isopropyl alcohol is flammable and its vapor is potentially explosive. Do not use cleaning solvent in the vicinity of spark, open flame, or excessive heat. Do not use cleaning solvent in unventilated spaces. Failure to follow these precautions can result in death or serious injury.

13. Clean the slingers (figure 1, item 18), wrist pins (figure 1, item 19), and plunger rods (figure 1, item 15) with isopropyl alcohol and rags. Inspect for signs of damage and wear, and set aside.
14. Clean the three plunger bores (figure 1, item 20) inside the crankcase (figure 1, item 9) with rags and isopropyl alcohol, and inspect for signs of rust and damage.
15. Clean the six valve oil seal cavities (figure 1, item 21) inside the manifold (figure 1, item 7) with isopropyl alcohol and rags, and inspect for damage, erosion, or etching.

ASSEMBLY**NOTE**

Ensure that the seal cavities are dry. Use no lubricant to install the plunger oil seals.

1. Assemble the plungers as follows:
 - a. Install the new anti-extrusion ring (figure 1, item 17) on the plunger rod (figure 1, item 15).
 - b. Lubricate the new plunger O-ring (figure 1, item 16) with silicone lubricant, and install it on the plunger rod (figure 1, item 15).

-
- c. Install the new ceramic plunger (figure 1, item 14) on the plunger rod (figure 1, item 15).
 - d. Install the plunger retaining nut (figure 1, item 12) and new washer (figure 1, item 13) on the plunger rod (figure 1, item 15) and tighten to 88 lb-in (9.9 Nm) torque.
2. Place a small dab of thread locking compound on the exposed threads of each plunger rod.
 3. Install the three plunger assemblies (figure 1, item 11) in the pump crankcase (figure 1, item 9).

NOTE

Use no lubrication when installing the valve oil seal assemblies.

4. Use the seal installation tool to install the new valve oil seal assemblies (figure 1, item 10) in the cavities (figure 1, item 21) in the interior of the manifold (figure 1, item 7).
5. Place the manifold (figure 1, item 7) on the crankcase (figure 1, item 9).
6. Install the four upper (figure 1, item 5) and four lower (figure 1, item 6) manifold screws and eight flat washers (figure 1, item 8) finger tight.
7. Tighten each manifold screw to 96 lb-in (10.8 Nm) torque.
8. Lubricate the six new valve spacer O-rings (figure 1, item 4) with silicone compound, and install one O-ring on each valve assembly (figure 1, item 3).
9. Install the three new valve assemblies (figure 1, item 3).
10. Lubricate the six new valve plug O-rings (figure 1, item 2) with silicone compound, and install one on each valve plug (figure 1, item 1).
11. Install the six valve plugs (figure 1, item 1), and tighten to 42 lb-in (4.7 Nm) torque.

END OF WORK PACKAGE

**DIRECT SUPPORT MAINTENANCE
REVERSE OSMOSIS WATER PURIFICATION UNIT FOR
INLAND AND COASTAL LARGE TUG (LT)
CHARCOAL FILTER, REPLACE**

INITIAL SETUP:**Tools and Special Tools:**

Tool Kit, General Mechanic's (Item 1, Table 2,
WP 0031 00)

Personnel Required:

Two Watercraft Engineers, 88L

Materials/Parts:

Lubricant, Silicone (Item 11, Table 1,
WP 0035 00)
Rag, Wiping (Item 14, Table 1, WP 0035 00)
Tag, Danger (Item 17, Table 1, WP 0035 00)
10-Micron Filter Assembly (Item 1, Figure 7,
WP 0033 00)
Briquette, Carbon (Filter Element) (Item 3,
Figure 7, WP 0033 00)
O-Ring (Item 2, Figure 7, WP 0033 00)

References:

FM 55-502
WP 0005 00
WP 0031 00
WP 0033 00
WP 0035 00

Equipment Conditions:

Applicable ROWPU shut down (WP 0005 00)
CLOSE, lock out, and tag out (FM 55-502) valve
RO-V-7.

REPLACE CHARCOAL FILTER ASSEMBLY**DISASSEMBLY**

1. Unscrew the applicable filter bowl (figure 1, item 1) from the lid (figure 1, item 2).
2. Disconnect the inlet tubing (figure 1, item 3) and outlet tubing (figure 1, item 4) from the pipe fittings (figure 1, item 5).
3. Remove the four sets of bolts (figure 1, item 6) and four flat washers (figure 1, item 7) that secure the lid (figure 1, item 2) to the mounting bracket (figure 1, item 8).
4. Remove the pipe fittings (figure 1, item 5) from the lid (figure 1, item 2).
5. Remove the carbon briquette (filter element) (figure 1, item 9) from the filter bowl (figure 1, item 1). Discard the carbon briquette.
6. Remove the O-ring (figure 1, item 10) from the filter bowl (figure 1, item 1). Discard the O-ring.

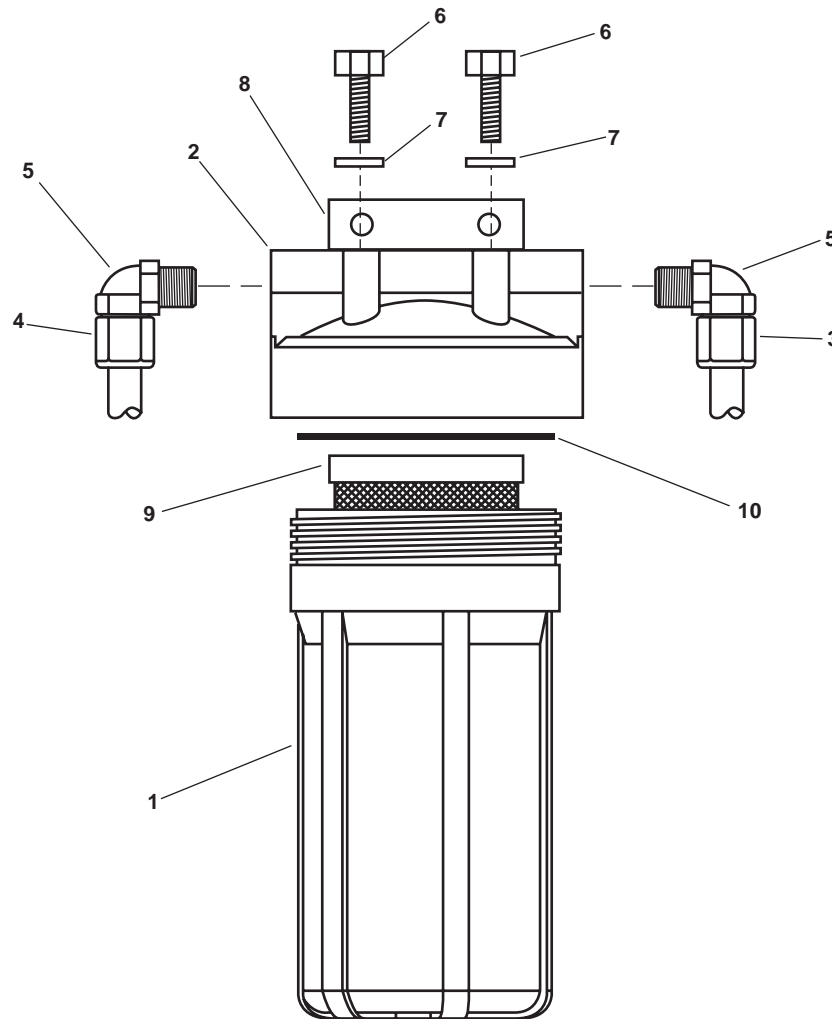

Figure 1. Charcoal Filter Assembly

ASSEMBLY

1. Install the pipe fittings (figure 1, item 5) into the lid (figure 1, item 2).
2. Position the lid (figure 1, item 2) to the mounting bracket (figure 1, item 8), and secure it in place with four bolts (figure 1, item 6) and four flat washers (figure 1, item 7).
3. Connect the outlet tubing (figure 1, item 4) and inlet tubing (figure 1, item 3) to the pipe fittings (figure 1, item 5).
4. Inspect for and remove any debris and foreign matter from the filter bowl (figure 1, item 1).
5. Thoroughly clean the lid (figure 1, item 2), using fresh water and clean rags.
6. Place a new carbon briquette (filter element) (figure 1, item 9) into the filter bowl (figure 1, item 1).
7. Lubricate a new O-ring (figure 1, item 10) with silicone lubricant and install it in the groove in the filter bowl (figure 1, item 1).

8. Position the filter bowl (figure 1, item 1) in contact with the lid (figure 1, item 2) and tighten until snug.
9. Remove the lockouts and tagouts (FM 55-502).
10. Perform Fresh Water Flush (WP 0005 00) and inspect the charcoal filter for leaks.
11. Return the equipment to the desired readiness condition.

END OF WORK PACKAGE

Chapter 8

General Support Maintenance Instructions for Reverse Osmosis Water Purification Unit Inland and Coastal Large Tug (LT)

**GENERAL SUPPORT MAINTENANCE
REVERSE OSMOSIS WATER PURIFICATION UNIT FOR
INLAND AND COASTAL LARGE TUG (LT)
REVERSE OSMOSIS WATER PURIFICATION UNIT, REPAIR**

INITIAL SETUP:**Tools and Special Tools:**

Tool Kit, General Mechanic's (Item 1, Table 2,
WP 0031 00)

Materials/Parts:

Lubricant, Silicone (Item 11, Table 1,
WP 0035 00)
Tag, Danger (Item 17, Table 1, WP 0035 00)
High Pressure Hose (Item 14, Figure 5,
WP 0033 00)
Swivel (Item 13, Figure 5, WP 0033 00)

References:

FM 55-502
WP 0005 00
WP 0031 00
WP 0033 00
WP 0035 00

Equipment Conditions:

CLOSE, lock out, and tag out (FM 55-502) valve
RO-V-9.
Set to OFF, lock out, and tag out the FWF PUMP
circuit breaker at the 24 VDC control panel.

Personnel Required:

Two Watercraft Engineers, 88L

REPLACE HIGH PRESSURE HOSES**REMOVAL**

Replace or repair components only after the affected circuit has been secured, locked out, and tagged out. Performing replacement with the circuit energized may result in serious injury or death.

1. Shut down the applicable ROWPU (WP 0005 00).
2. At 440V power panel No. 5, set to OFF, lock out, and tag out (FM 55-502) the applicable circuit breaker as shown in table 1.
3. At the 24 Vdc control panel, set to OFF, lock out, and tag out (FM 55-502) the applicable circuit breaker as shown in table 1.
4. CLOSE, lock out, and tag out (FM 55-502) the applicable inlet sea water supply valve as shown in table 1.

■ Table 1. ROWPU Lockout/Tagout Guide

ROWPU	Power Panel 5 Breaker	Inlet Sea Water Valve	24 Vdc Control Panel
1	REVERSE OSMOSIS WATER MAKER No. 1 (LT 803 Only) LVP FOR REVERSE OSMOSIS WATER MAKER No. 1 (All Other Vessels)	RO-V-1-1	RO #1
2	REVERSE OSMOSIS WATER MAKER No. 2 (LT 803 Only) LVP FOR REVERSE OSMOSIS WATER MAKER No. 2 (All Other Vessels)	RO-V-2-1	RO #2

5. Use the two wrench method to disconnect the faulty high pressure hose (figure 1, item 1) by placing the stationary wrench on the male fitting (figure 1, item 2), and rotating the female fitting (figure 1, item 3).

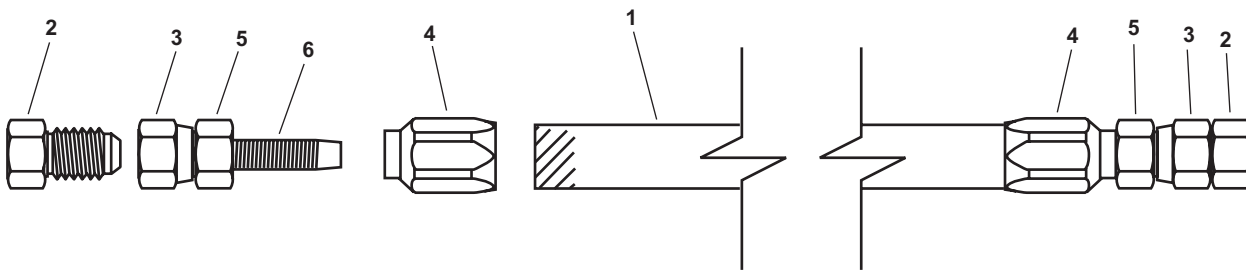

Figure 1. High Pressure Hose

FABRICATE HIGH PRESSURE HOSE SECTION

1. Measure the complete length of the old hose from end to end, including the length of all installed fittings.
2. Cut the new section of high pressure hose $2\frac{3}{4}$ in (70 mm) shorter than the measurement of the entire length of the old high pressure hose.
3. Disassemble the old hose by holding the sockets (figure 1, item 4) stationary and rotating the female fittings (figure 1, item 5) counterclockwise until removed.
4. Separate the old high pressure hose (figure 1, item 1) from the sockets (figure 1, item 4) and discard the faulty section of high pressure hose.
5. Inspect the female fittings (figure 1, item 3), male fittings (figure 1, item 2), and the sockets (figure 1, item 4) for excessive wear and damage. Replace any damaged parts.
6. Lubricate the ends of the replacement high pressure hose (figure 1, item 1) with silicone compound.
7. Install the ends of the high pressure hose (figure 1, item 1) in the sockets (figure 1, item 4) by holding the sockets stationary, and rotating the high pressure hose counterclockwise until it bottoms in the socket.

8. Rotate the high pressure hose (figure 1, item 1) clockwise in the socket (figure 1, item 4) $\frac{1}{2}$ turn, and ensure that the hose is not bottomed in the socket.
9. Lubricate the threaded nipple (figure 1, item 6) on each of the female fittings (figure 1, item 5) with silicone compound.
10. Install the female fittings (figure 1, item 5) in the sockets (figure 1, item 4) by holding the sockets stationary and rotating the female fittings clockwise until snug. Back off $\frac{1}{8}$ of a turn.

INSTALLATION

1. Install the high pressure hose (figure 1, item 1) using the two wrench method by holding the male fitting (figure 1, item 2) stationary, and rotating the female fitting (figure 1, item 3) until tight.
2. Remove the lockouts and tagouts (FM 55-502).
3. Perform startup on the applicable ROWPU (WP 0005 00) and check for any leaks.
4. Return the equipment to the desired readiness condition.

END OF WORK PACKAGE

Chapter 9

Supporting Information
for
Reverse Osmosis Water Purification Unit

Inland and Coastal Large Tug (LT)

**OPERATOR, UNIT, DIRECT SUPPORT, AND GENERAL SUPPORT MAINTENANCE
REVERSE OSMOSIS WATER PURIFICATION UNIT FOR
INLAND AND COASTAL LARGE TUG (LT)
REFERENCES**

This work package lists all field manuals, forms, technical manuals, and miscellaneous publications referenced in this manual.

ARMY REGULATIONS

AR 700-138 Army Logistics Readiness and Sustainability

FIELD MANUALS

FM 4-25.11 First Aid
FM 55-502 Watercraft Safety
FM 55-509-1 Introduction to Marine Electricity

TECHNICAL MANUALS

TM 38-470 Storage and Maintenance of Army Prepositioned Stock Materiel
TM 55-1925-273-10 Operator's Manual for Inland and Coastal Large Tug (LT) NSN 1925-01-509-7013
TM 750-244-6 Procedures for Destruction of Tank-Automotive Equipment to Prevent Enemy Use

TECHNICAL BULLETINS

TB 43-0218 Inspection, Use and Tightening of Metal Fasteners Used on Tank-Automotive Equipment
TB 740-97-4 Preservation of Vessels for Storage

FORMS AND PAMPHLETS

DA Form 2028 Recommended Changes to Equipment Technical Publications
DA Form 2404 Equipment Inspection and Maintenance Worksheet
DA Form 2407 Maintenance Request
DA Form 2408-9 Equipment Control Record
DA Form 4640 Harbor Boat Deck Department Log for Class A&B Vessels
DA Form 4993 Harbor Boat Engine Department Log for Class A and C-1 Vessels
DA PAM 738-750 Functional Users Manual for The Army Maintenance Management System (TAMMS)
SF 368 Product Quality Deficiency Report

HANDBOOKS AND STANDARDS

MIL-HDBK- 113 Guide for the Selection of Lubricants, Functional Fluids, Preservatives, and Specialty Products for Use in Ground Equipment Systems
MIL-HDBK-275 Guide for the Selection of Lubricant Fluids and Compounds for Use in Flight Vehicles and Components

END OF WORK PACKAGE

**OPERATOR, UNIT, DIRECT SUPPORT, AND GENERAL SUPPORT MAINTENANCE
REVERSE OSMOSIS WATER PURIFICATION UNIT FOR
INLAND AND COASTAL LARGE TUG (LT)
MAINTENANCE ALLOCATION CHART (MAC)
INTRODUCTION**

THE ARMY MAINTENANCE SYSTEM MAC

This introduction provides a general explanation of all maintenance and repair functions authorized at various maintenance levels under the standard Army Maintenance System concept.

The MAC (immediately following the introduction) designates overall authority and responsibility for the performance of maintenance functions on the identified end item or component. The application of the maintenance functions to the end item or component shall be consistent with the capacities and capabilities of the designated maintenance levels, which are shown on the MAC in column (4) as:

Unit — includes two subcolumns, C (operator/crew) and O (unit) maintenance.

Direct Support — includes an F subcolumn.

General Support — includes an H subcolumn.

Depot — includes a D subcolumn.

The tools and test equipment requirements (immediately following the MAC) list the tools and test equipment (both special tools and common tool sets) required for each maintenance function as referenced from the MAC.

The remarks (immediately following the tools and test equipment requirements) contain supplemental instructions and explanatory notes for a particular maintenance function.

MAINTENANCE FUNCTIONS

Maintenance functions are limited to and defined as follows:

1. **Inspect.** To determine the serviceability of an item by comparing its physical, mechanical, and/or electrical characteristics with established standards through examination (e.g., by sight, sound, or feel). This includes scheduled inspection and gagings and evaluation of cannon tubes.
2. **Test.** To verify serviceability by measuring the mechanical, pneumatic, hydraulic, or electrical characteristics of an item and comparing those characteristics with prescribed standards on a scheduled basis, i.e., load testing of lift devices and hydrostatic testing of pressure hoses.
3. **Service.** Operations required periodically to keep an item in proper operating condition; e.g., to clean (includes decontaminate, when required), to preserve, to drain, to paint, or to replenish fuel, lubricants, chemical fluids, or gases. This includes scheduled exercising and purging of recoil mechanisms.
4. **Adjust.** To maintain or regulate, within prescribed limits, by bringing into proper position, or by setting the operating characteristics to specified parameters.
5. **Align.** To adjust specified variable elements of an item to bring about optimum or desired performance.
6. **Calibrate.** To determine and cause corrections to be made or to be adjusted on instruments of test, measuring, and diagnostic equipment used in precision measurement. Consists of comparisons of two instruments, one of which is a certified standard of known accuracy, to detect and adjust any discrepancy in the accuracy of the instrument being compared.

7. Remove/Install. To remove and install the same item when required to perform service or other maintenance functions. Install may be the act of emplacing, seating, or fixing into position a spare, repair part, or module (component or assembly) in a manner to allow the proper functioning of an equipment or system.
8. Replace. To remove an unserviceable item and install a serviceable counterpart in its place. "Replace" is authorized by the MAC and assigned maintenance level is shown as the third position code of the Source, Maintenance and Recoverability (SMR) code.
9. Repair. The application of maintenance services, including fault location/troubleshooting, removal/installation, disassembly/assembly procedures, and maintenance actions to identify troubles and restore serviceability to an item by correcting specific damage, fault, malfunction, or failure in a part, subassembly, module (component or assembly), end item, or system.

NOTE

The following definitions are applicable to the "repair" maintenance function:

Services. Inspect, test, service, adjust, align, calibrate, and/or replace.

Fault location/troubleshooting. The process of investigating and detecting the cause of equipment malfunctioning; the act of isolating a fault within a system or Unit Under Test (UUT).

Disassembly/assembly. The step-by-step breakdown (taking apart) of a spare/functional group coded item to the level of its least component, that is assigned an SMR code for the level of maintenance under consideration (i.e., identified as maintenance significant).

Actions. Welding, grinding, riveting, straightening, facing, machining, and/or resurfacing.

10. Overhaul. That maintenance effort (service/action) prescribed to restore an item to a completely serviceable/operational condition as required by maintenance standards in appropriate technical publications. Overhaul is normally the highest degree of maintenance performed by the Army. Overhaul does not normally return an item to like new condition.
11. Rebuild. Consists of those services/actions necessary for the restoration of unserviceable equipment to a like new condition in accordance with original manufacturing standards. Rebuild is the highest degree of materiel maintenance applied to Army equipment. The rebuild operation includes the act of returning to zero those age measurements (e.g., hours/miles) considered in classifying Army equipment/components.

EXPLANATION OF COLUMNS IN THE MAC

Column (1) Group Number. Column (1) lists FGC numbers, the purpose of which is to identify maintenance significant components, assemblies, subassemblies, and modules with the Next Higher Assembly (NHA).

Column (2) Component/Assembly. Column (2) contains the item names of components, assemblies, subassemblies, and modules for which maintenance is authorized.

Column (3) Maintenance Function. Column (3) lists the functions to be performed on the item listed in column (2). (For a detailed explanation of these functions refer to "Maintenance Functions" outlined above.)

Column (4) Maintenance Level. Column (4) specifies each level of maintenance authorized to perform each function listed in column (3), by indicating work time required (expressed as manhours in whole hours or decimals) in the appropriate subcolumn. This work time figure represents the active time required to perform that maintenance function at the indicated level of maintenance. If the number or complexity of the tasks within the listed maintenance function varies at different maintenance levels, appropriate work time figures are to be shown

for each level. The work time figure represents the average time required to restore an item (assembly, subassembly, component, module, end item, or system) to a serviceable condition under typical field operating conditions. This time includes preparation time (including any necessary disassembly/assembly time), troubleshooting/fault location time, and quality assurance time in addition to the time required to perform the specific tasks identified for the maintenance functions authorized in the MAC. The symbol designations for the various maintenance levels are as follows:

- C Operator or crew maintenance
- O Unit maintenance
- F Direct support maintenance
- L Specialized repair activity (SRA)
- H General support maintenance
- D Depot maintenance

NOTE

The "L" maintenance level is not included in column (4) of the MAC. Functions to this level of maintenance are identified by a work time figure in the "H" column of column (4), and an associated reference code is used in the REMARKS column (6). This code is keyed to the remarks and the SRA complete repair application is explained there.

Column (5) Tools and Equipment Reference Code. Column (5) specifies, by code, those common tool sets (not individual tools), common Test, Measurement and Diagnostic Equipment (TMDE), and special tools, special TMDE and special support equipment required to perform the designated function. Codes are keyed to the entries in the tools and test equipment table.

Column (6) Remarks Code. When applicable, this column contains a letter code, in alphabetical order, which is keyed to the remarks table entries.

EXPLANATION OF COLUMNS IN THE TOOLS AND TEST EQUIPMENT REQUIREMENTS

Column (1) Tool or Test Equipment Reference Code. The tool or test equipment reference code correlates with a code used in column (5) of the MAC.

Column (2) Maintenance Level. The lowest level of maintenance authorized to use the tool or test equipment.

Column (3) Nomenclature. Name or identification of the tool or test equipment.

Column (4) National Stock Number (NSN). The NSN of the tool or test equipment.

Column (5) Tool Number. The manufacturer's part number, model number, or type number.

EXPLANATION OF COLUMNS IN THE REMARKS

Column (1) Remarks Code. The code recorded in column (6) of the MAC.

Column (2) Remarks. This column lists information pertinent to the maintenance function being performed as indicated in the MAC.

END OF WORK PACKAGE

**OPERATOR, UNIT, DIRECT SUPPORT, AND GENERAL SUPPORT MAINTENANCE
REVERSE OSMOSIS WATER PURIFICATION UNIT FOR
INLAND AND COASTAL LARGE TUG (LT)
MAINTENANCE ALLOCATION CHART**

Table 1. MAC for Reverse Osmosis Water Purification Units

(1) GROUP NUMBER	(2) COMPONENT/ ASSEMBLY	(3) MAINTENANCE FUNCTION	(4) MAINTENANCE LEVEL					(5) TOOLS AND EQUIP	(6) REMARKS
			FIELD		SUSTAINMENT				
			UNIT		DIRECT SUPPORT	GENERAL SUPPORT	DEPOT		
			C	O	F	H	D		
051604	Reverse Osmosis Water Maker	Inspect	0.4					1	
		Service	0.4					1, 5, 6	
		Replace						1, 2	
		Repair		1.5	3.0	16.0	--	1, 2, 3, 10	
05160401	Fresh Water Flush Pump (Jabsco)	Inspect	0.3					1	
		Service	0.4					2, 3	
		Replace		2.0					
05160402	Media Filter Subassembly (Sand Filter)	Inspect	0.5					1, 4	
		Service	0.8					1, 7	
		Repair		2.0					
05160403	Prefiltration Subassembly (5 & 20 micron filter)	Inspect	1.0					1	
		Service	2.0					1	
		Replace			2.0				
05160404	High Pressure Pump	Inspect	0.3					1, 3	A
		Service	0.3					2, 3	
		Replace		2.0				1, 7, 8, 9	
		Repair			8.0				
05160405	Membrane and Vessel Subassembly	Inspect	0.3					1	
		Replace		4.0				1	
		Repair		2.0					
05160406	Charcoal Filter	Inspect	0.3					1	
		Service		1.0				1	
		Replace			2.0				

Table 2. Tools and Test Equipment for Reverse Osmosis Water Purification Units

TOOL OR TEST EQUIPMENT REF CODE	MAINTENANCE LEVEL	NOMENCLATURE	NATIONAL STOCK NUMBER	TOOL NUMBER
1	C	Tool Kit,General Mechanic's	5180-00-629-9783	SC5180-90-CL-N55 (50980)
2	O	Tool Kit,Electrician's	5180-00-313-3045	MILT11196 (81349)
3	O	Multimeter, AN/PSM45A	6625-01-265-6000	27 W/ACCE (89536)
4	C	Cleaner,Vacuum,Electric	7910-00-550-9120	Model 2815 (80029)
5	O	Lubricating Gun,Hand	4930-00-223-3389	7584 (0FKM1)
6	O	Cleaning Hose		
7	O	Wrench,Torque,0-600 IN-LB	5120-00-288-8865	B107.14M (05047)
8	F	Slide Hammer,Packing Extraction	5120-01-530-7892	45001225CO (1BZ02)
9	F	Socket,Packing Extraction		45001205CO (1BZ02)
10	F	Brush,Bottle and Buret	7920-00-285-9100	7920-00-285-9100 (80244)

Table 3. Remarks for Reverse Osmosis Water Purification Units

REFERENCE CODE	REMARKS
A	Change High Pressure Pump crankcase oil after first 50 hours of operation and every 500 hours thereafter.

END OF WORK PACKAGE

**OPERATOR, UNIT, DIRECT SUPPORT, AND GENERAL SUPPORT MAINTENANCE
REVERSE OSMOSIS WATER PURIFICATION UNIT FOR
INLAND AND COASTAL LARGE TUG (LT)
REPAIR PARTS AND SPECIAL TOOLS LIST
INTRODUCTION**

SCOPE

This RPSTL lists and authorizes spares and repair parts; special tools; special test, measurement, and diagnostic equipment (TMDE); and other special support equipment required for performance of operator, unit, direct support, and general support maintenance of the reverse osmosis water purification unit for Inland and Coastal Large Tug (LT). It authorizes the requisitioning, issue, and disposition of spares, repair parts, and special tools as indicated by the source, maintenance, and recoverability (SMR) codes.

GENERAL

In addition to the Introduction work package, this RPSTL is divided into the following work packages.

1. **Repair Parts List Work Packages.** Work packages containing lists of spares and repair parts authorized by this RPSTL for use in the performance of maintenance. These work packages also include parts which must be removed for replacement of the authorized parts. Parts lists are composed of functional groups in ascending alphanumeric sequence, with the parts in each group listed in ascending figure and item number sequence. Sending units, brackets, filters, and bolts are listed with the component they mount on. Bulk materials are listed by item name in FIG. BULK at the end of the work packages. Repair parts kits are listed separately in their own functional group and work package. Repair parts for reparable special tools are also listed in a separate work package. Items listed are shown on the associated illustrations.
2. **Special Tools List Work Packages.** Work packages containing lists of special tools, special TMDE, and special support equipment authorized by this RPSTL (as indicated by Basis of Issue (BOI) information in the DESCRIPTION AND USABLE ON CODE (UOC) column). Tools that are components of common tool sets and/or Class VII are not listed.
3. **Cross-Reference Indexes Work Packages.** There are two crossreference indexes work packages in this RPSTL: the National Stock Number (NSN) Index work package and the Part Number (P/N) Index work package. The National Stock Number Index work package refers you to the figure and item number. The Part Number Index work package refers you to the figure and item number.

EXPLANATION OF COLUMNS IN THE REPAIR PARTS LIST AND SPECIAL TOOLS LIST WORK PACKAGES

ITEM NO. (Column (1)). Indicates the number used to identify items called out in the illustration.

SMR CODE (Column (2)). The SMR code containing supply/requisitioning information, maintenance level authorization criteria, and disposition instruction, as shown in the following breakout:

<u>Source Code</u>	<u>Maintenance Code</u>		<u>Recoverability Code</u>
XX	XX		X
1st two positions: How to get an item.	3rd position: Who can install, replace, or use the item.	4th position: Who can do complete repair* on the item.	5th position: Who determines disposition action on unserviceable items.

*Complete Repair: Maintenance capacity, capability, and authority to perform all corrective maintenance tasks of the "Repair" function in a use/user environment in order to restore serviceability to a failed item.

Source Code. The source code tells you how you get an item needed for maintenance, repair, or overhaul of an end item/equipment. Explanations of source codes follow:

<u>Source Code</u>	<u>Application/Explanation</u>
PA PB PC PD PE PF PG	<p>Stock items; use the applicable NSN to requisition/request items with these source codes. They are authorized to the level indicated by the code entered in the 3rd position of the SMR code.</p> <p style="text-align: center;">NOTE Items coded PC are subject to deterioration.</p>
KD KF KB	<p>Items with these codes are not to be requested/requisitioned individually. They are part of a kit which is authorized to the maintenance level indicated in the 3rd position of the SMR code. The complete kit must be requisitioned and applied.</p>
MO-Made at unit/AVUM level MF-Made at DS/AVIM level MH-Made at GS level ML-Made at SRA MD-Made at depot	<p>Items with these codes are not to be requisitioned/requested individually. They must be made from bulk material which is identified by the P/N in the DESCRIPTION AND USABLE ON CODE (UOC) column and listed in the bulk material group work package of the RPSTL. If the item is authorized to you by the 3rd position code of the SMR code, but the source code indicates it is made at higher level, order the item from the higher level of maintenance.</p>
AO-Assembled by unit/ AVUM level AF-Assembled by DS/AVIM level AH-Assembled by GS level AL-Assembled by SRA AD-Assembled by depot	<p>Items with these codes are not to be requested/requisitioned individually. The parts that make up the assembled item must be requisitioned or fabricated and assembled at the level of maintenance indicated by the source code. If the 3rd position of the SMR code authorizes you to replace the item, but the source code indicates the item is assembled at a higher level, order the item from the higher level of maintenance.</p>
XA	<p>Do not requisition an "XA" coded item. Order the next higher assembly.(Refer to NOTE below.)</p>
XB	<p>If an item is not available from salvage, order it using the CAGEC and P/N.</p>
XC	<p>Installation drawings, diagrams, instruction sheets, field service drawings; identified by manufacturer's P/N.</p>
XD	<p>Item is not stocked. Order an XD-coded item through normal supply channels using the CAGEC and P/N given, if no NSN is available.</p> <p style="text-align: center;">NOTE Cannibalization or controlled exchange, when authorized, may be used as a source of supply for items with the above source codes except for those items source coded "XA" or those aircraft support items restricted by requirements of AR 750-1.</p>

Maintenance Code. Maintenance codes tell you the level(s) of maintenance authorized to use and repair support items. The maintenance codes are entered in the third and fourth positions of the SMR code as follows:

Third Position. The maintenance code entered in the third position tells you the lowest maintenance level authorized to remove, replace, and use an item. The maintenance code entered in the third position will indicate authorization to the following levels of maintenance:

<u>Maintenance Code</u>	<u>Application/Explanation</u>
C -	Crew or operator maintenance done within unit/AVUM maintenance.
O -	Unit level/AVUM maintenance can remove, replace, and use the item.
F -	Direct support/AVIM maintenance can remove, replace, and use the item.
H -	General support maintenance can remove, replace, and use the item.
L -	Specialized repair activity can remove, replace, and use the item.
D -	Depot can remove, replace, and use the item.

Fourth Position. The maintenance code entered in the fourth position tells you whether or not the item is to be repaired and identifies the lowest maintenance level with the capability to do complete repair (perform all authorized repair functions).

NOTE

Some limited repair may be done on the item at a lower level of maintenance, if authorized by the Maintenance Allocation Chart (MAC) and SMR codes.

<u>Maintenance Code</u>	<u>Application/Explanation</u>
O -	Unit/AVUM is the lowest level that can do complete repair of the item.
F -	Direct support/AVIM is the lowest level that can do complete repair of the item.
H -	General support is the lowest level that can do complete repair of the item.
L -	Specialized repair activity (enter specialized repair activity designator) is the lowest level that can do complete repair of the item.
D -	Depot is the lowest level that can do complete repair of the item.
Z -	Nonrepairable. No repair is authorized.
B -	No repair is authorized. No parts or special tools are authorized for maintenance of "B" coded item. However, the item may be reconditioned by adjusting, lubricating, etc., at the user level.

Recoverability Code. Recoverability codes are assigned to items to indicate the disposition action on unserviceable items. The recoverability code is shown in the fifth position of the SMR code as follows:

<u>Recoverability Code</u>	<u>Application/Explanation</u>
Z -	Nonrepairable item. When unserviceable, condemn and dispose of the item at the level of maintenance shown in the third position of the SMR code.

<u>Recoverability Code</u>	<u>Application/Explanation</u>
O -	Reparable item. When uneconomically reparable, condemn and dispose of the item at the unit level.
F -	Reparable item. When uneconomically reparable, condemn and dispose of the item at the direct support level.
H -	Reparable item. When uneconomically reparable, condemn and dispose of the item at the general support level.
D -	Reparable item. When beyond lower level repair capability, return to depot. Condemnation and disposal of item are not authorized below depot level.
L -	Reparable item. Condemnation and disposal not authorized below Specialized Repair Activity (SRA).
A -	Item requires special handling or condemnation procedures because of specific reasons (such as precious metal content, high dollar value, critical material, or hazardous material). Refer to appropriate manuals/directives for specific instructions.

NSN (Column (3)). The NSN for the item is listed in this column.

CAGEC (Column (4)). The Commercial and Government Entity Code (CAGEC) is a five-digit code which is used to identify the manufacturer, distributor, or Government agency/activity that supplies the item.

PART NUMBER (Column (5)). Indicates the primary number used by the manufacturer (individual, company, firm, corporation, or Government activity), which controls the design and characteristics of the item by means of its engineering drawings, specifications, standards, and inspection requirements to identify an item or range of items.

NOTE

When you use an NSN to requisition an item, the item you receive may have a different P/N from the number listed.

DESCRIPTION AND USABLE ON CODE (UOC) (Column (6)). This column includes the following information:

1. The federal item name, and when required, a minimum description to identify the item.
2. P/Ns of bulk materials are referenced in this column in the line entry to be manufactured or fabricated.
3. Hardness Critical Item (HCI). A support item that provides the equipment with special protection from electromagnetic pulse (EMP) damage during a nuclear attack.
4. The statement END OF FIGURE appears just below the last item description in column (6) for a given figure in both the repair parts list and special tools list work packages.

QTY (Column (7)). The QTY (quantity per figure) column indicates the quantity of the item used in the breakout shown on the illustration/figure, which is prepared for a functional group, subfunctional group, or an assembly. A "V" appearing in this column instead of a quantity indicates that the quantity is variable and quantity may change from application to application.

EXPLANATION OF CROSS-REFERENCE INDEXES WORK PACKAGES FORMAT AND COLUMNS

1. National Stock Number (NSN) Index Work Package.

STOCK NUMBER Column. This column lists the NSN in National item identification number (NIIN) sequence. The NIIN consists of the last nine digits of the NSN.

NSN
 (e.g., 5385-01-574-1476)
 NIIN

When using this column to locate an item, ignore the first four digits of the NSN. However, the complete NSN should be used when ordering items by stock number.

FIG. Column. This column lists the number of the figure where the item is identified/located. The figures are in numerical order in the repair parts list and special tools list work packages.

ITEM Column. The item number identifies the item associated with the figure listed in the adjacent FIG. column. This item is also identified by the NSN listed on the same line.

2. **Part Number (P/N) Index Work Package.** P/Ns in this index are listed in ascending alphanumeric sequence (vertical arrangement of letter and number combinations which places the first letter or digit of each group in order A through Z, followed by the numbers 0 through 9 and each following letter or digit in like order).

PART NUMBER Column. Indicates the P/N assigned to the item.

FIG. Column. This column lists the number of the figure where the item is identified/located in the repair parts list and special tools list work packages.

ITEM Column. The item number is the number assigned to the item as it appears in the figure referenced in the adjacent figure number column.

Fabrication Instructions. Bulk materials required to manufacture items are listed in the bulk material functional group of this RPSTL. Part numbers for bulk material are also referenced in the Description Column of the line item entry for the item to be manufactured/fabricated. Detailed fabrication instructions for items source coded to be manufactured or fabricated are found in the applicable procedure.

Index Numbers. Items which have the word BULK in the figure column will have an index number shown in the item number column. This index number is a cross-reference between the NSN / P/N index work packages and the bulk material list in the repair parts list work package.

HOW TO LOCATE REPAIR PARTS

1. **When NSNs or P/Ns Are Not Known.**

First. Using the table of contents, determine the assembly group to which the item belongs. This is necessary since figures are prepared for assembly groups and subassembly groups, and lists are divided into the same groups.

Second. Find the figure covering the functional group or the subfunctional group to which the item belongs.

Third. Identify the item on the figure and note the number(s).

Fourth. Look in the repair parts list work packages for the figure and item numbers. The NSNs and part numbers are on the same line as the associated item numbers.

2. **When NSN Is Known.**

First. If you have the NSN, look in the STOCK NUMBER column of the NSN index work package. The NSN is arranged in NIIN sequence. Note the figure and item number next to the NSN.

Second. Turn to the figure and locate the item number. Verify that the item is the one you are looking for.

3. **When P/N Is Known.**

First. If you have the P/N and not the NSN, look in the PART NUMBER column of the P/N index work package. Identify the figure and item number.

Second. Look up the item on the figure in the applicable repair parts list work package.

END OF WORK PACKAGE

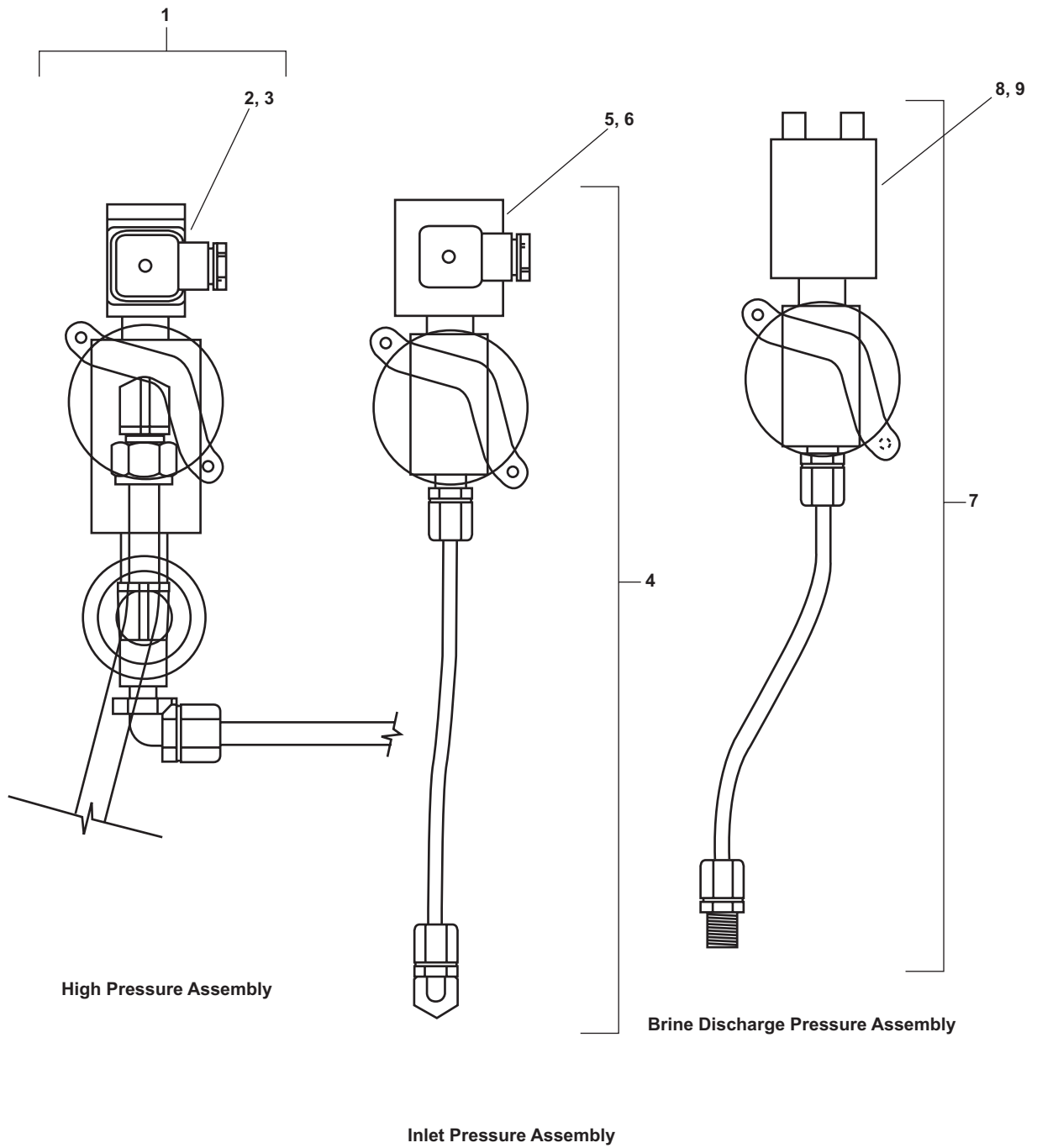
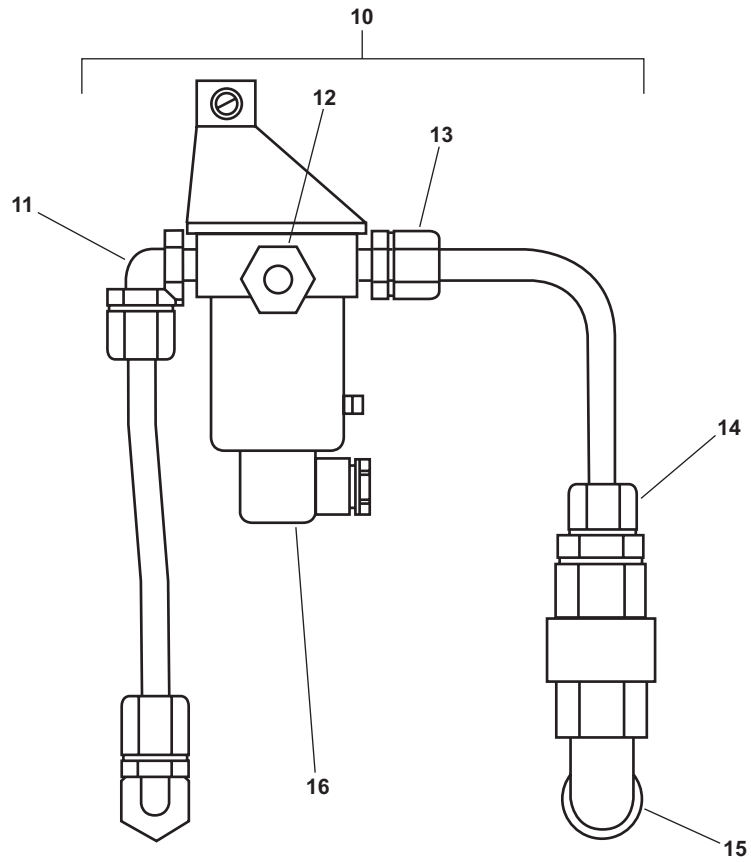

Figure 1. Water Purification Unit, Reverse Osmosis (Sheet 1 of 10)



Diversion Valve Assembly

Figure 1. Water Purification Unit, Reverse Osmosis (Sheet 2 of 10)

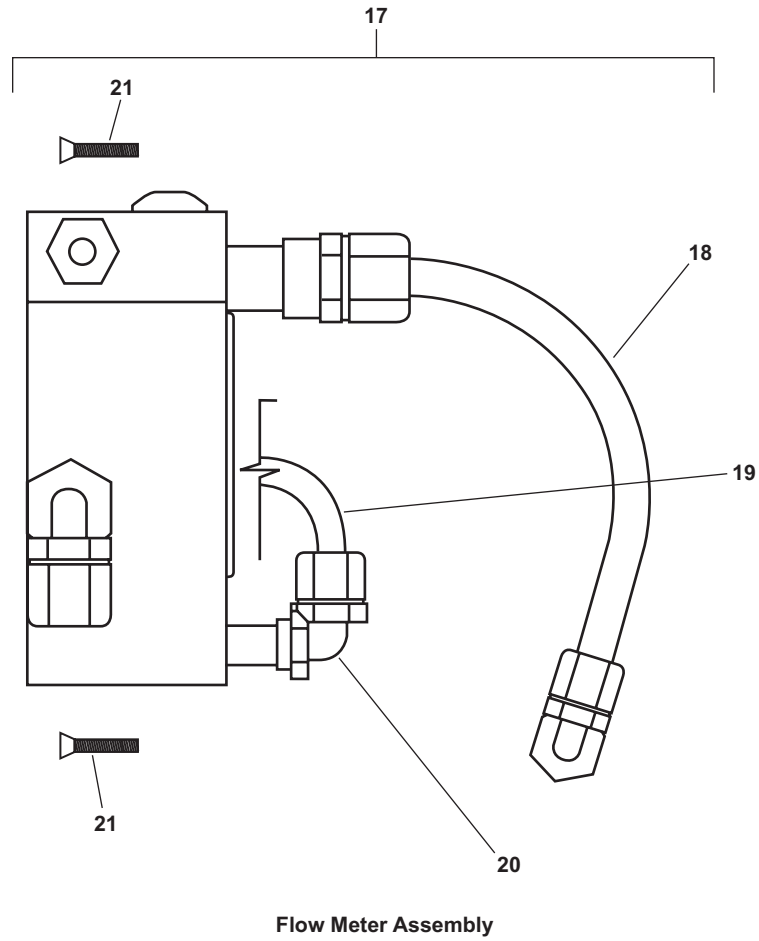
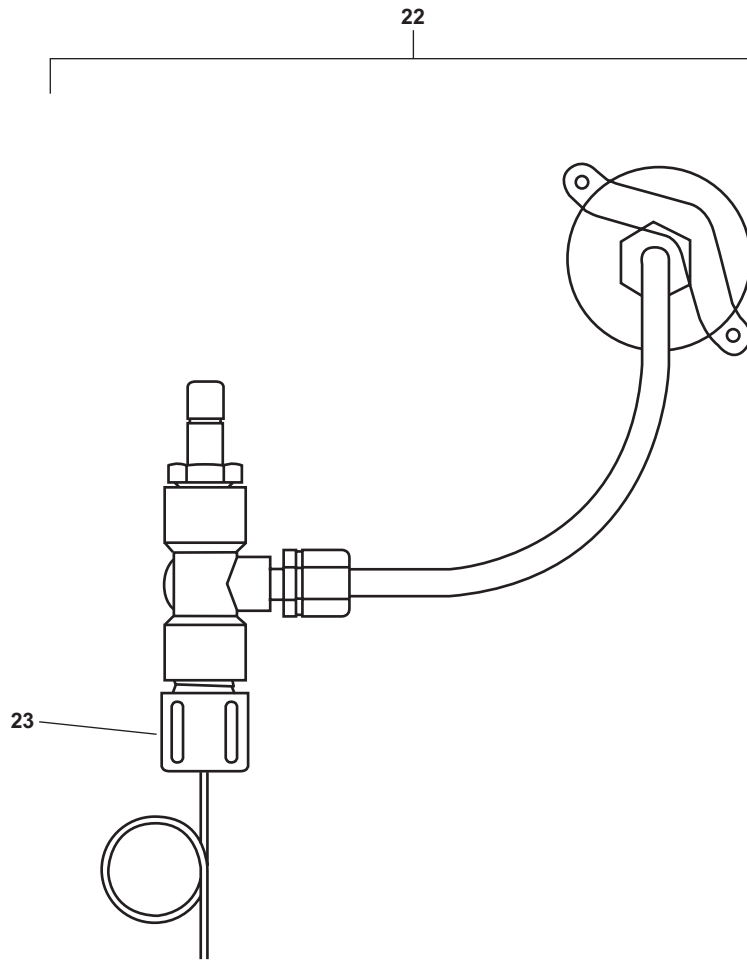

Figure 1. Water Purification Unit, Reverse Osmosis (Sheet 3 of 10)



Product Pressure Assembly

Figure 1. Water Purification Unit, Reverse Osmosis (Sheet 4 of 10)

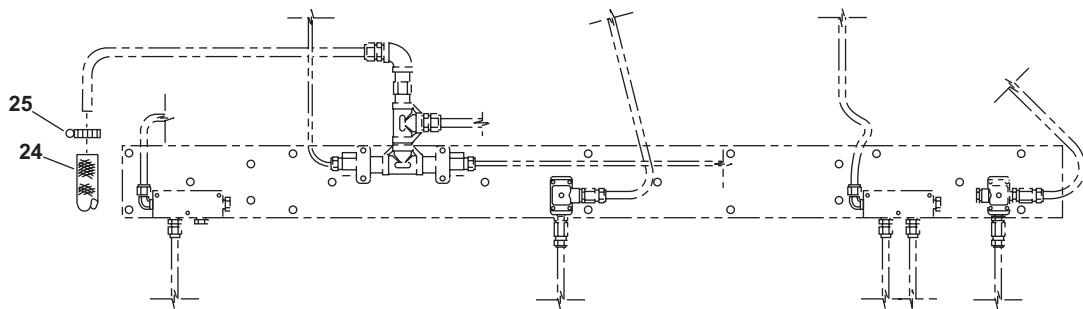

Figure 1. Water Purification Unit, Reverse Osmosis (Sheet 5 of 10)

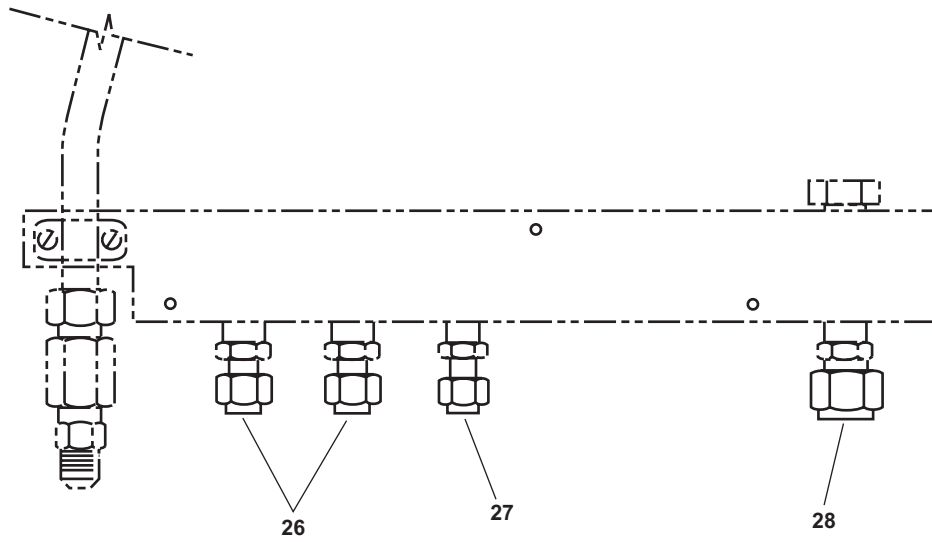
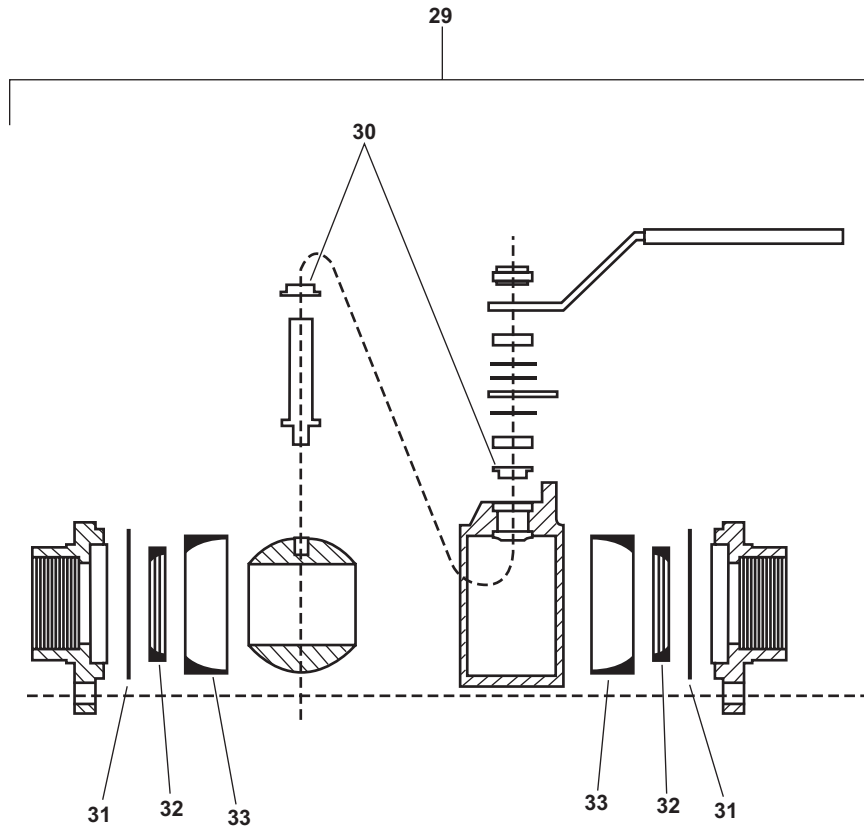
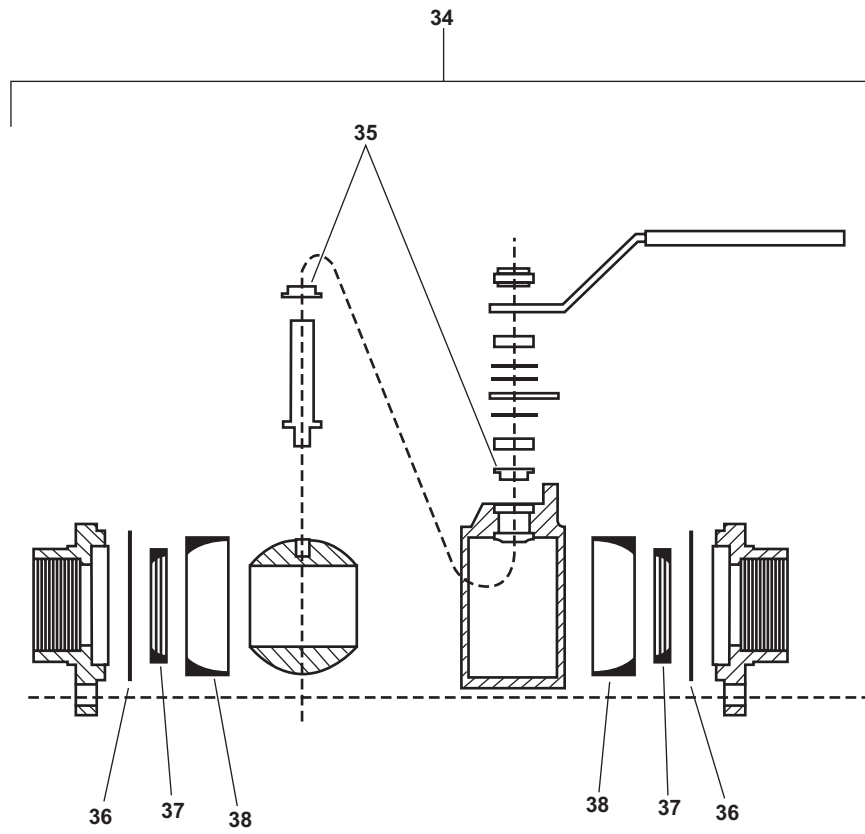

Figure 1. Water Purification Unit, Reverse Osmosis (Sheet 6 of 10)



3/4" Sil Braze Ball Valve

Figure 1. Water Purification Unit, Reverse Osmosis (Sheet 7 of 10)



1" Sil Braze Ball Valve

Figure 1. Water Purification Unit, Reverse Osmosis (Sheet 8 of 10)

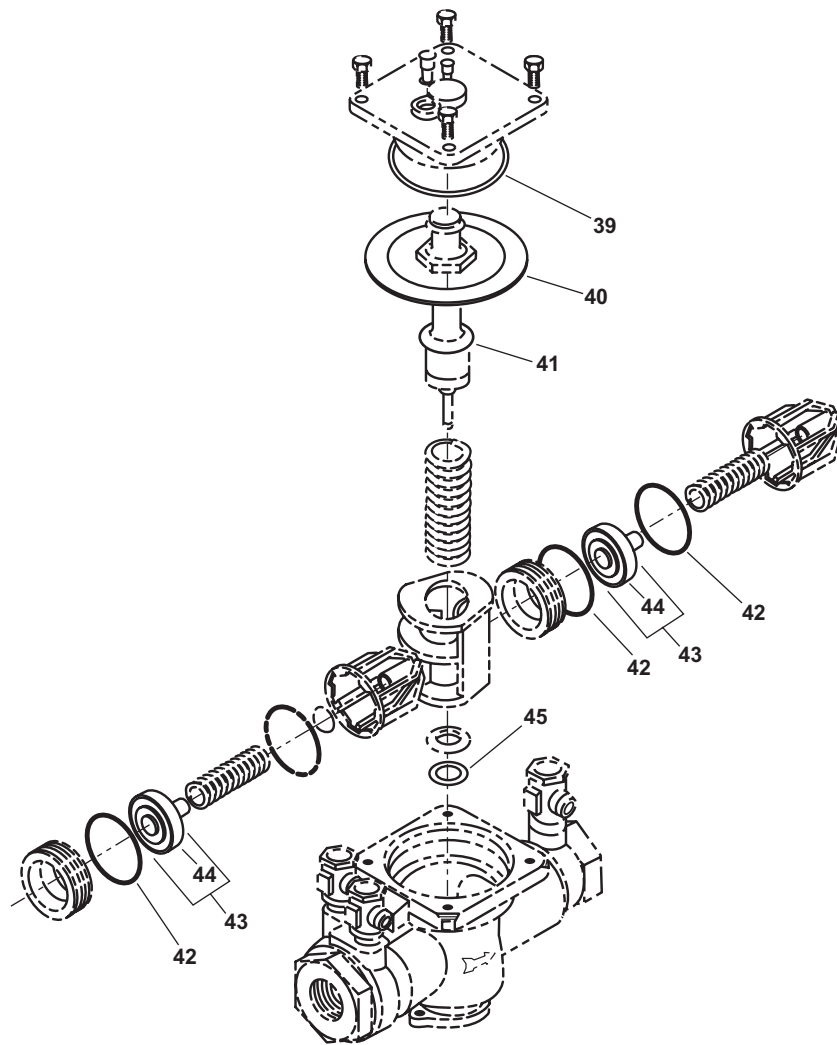

Back Flow Preventer Valve

Figure 1. Water Purification Unit, Reverse Osmosis (Sheet 9 of 10)

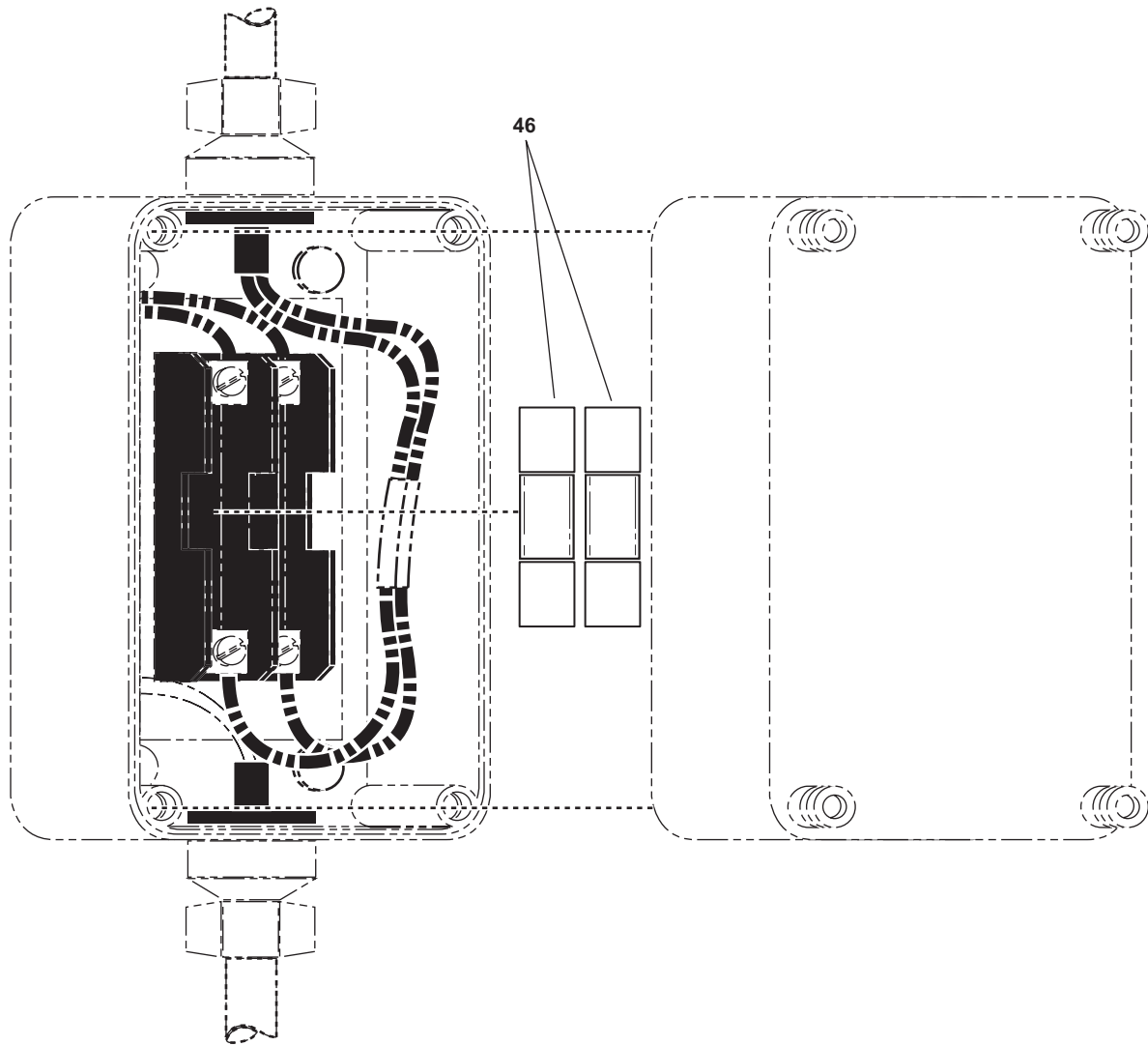

24 Vdc Fuse Box

Figure 1. Water Purification Unit, Reverse Osmosis (Sheet 10 of 10)

(1)	(2)	(3)	(4)	(5)	(6)	(7)
ITEM NO.	SMR CODE	NSN	CAGEC	PART NUMBER	DESCRIPTION AND USABLE ON CODE (UOC)	QTY
					GROUP 051604	
					FIG. 1 WATER PURIFICATION UNIT, REVERSE OSMOSIS	
1	XCOOO		05MH3	442909384	HIGH PRESSURE ASSEM	1
2	PAOZZ	5930-01-528-6706	1BZ02	2321020458	.SWITCH,HIGH PRESSUR	1
3	PAOZZ	5331-01-528-6701	1BZ02	2614015800	.O-RING GAUGE/PRESSURE SWITCH	6
4	XCOFF		05MH3	468398210	INLET PRESSURE ASSE	1
5	PAFZZ	5930-01-528-6737	1BZ02	2301020658	.SWITCH,LOW PRESSURE	1
6	PAFZZ	5331-01-528-6701	1BZ02	2614015800	.O-RING GAUGE/PRESSURE SWITCH	6
7	XCFFF		05MH3	437513061	BRINE DISCHARGE PRE	1
8	PAFZZ	6685-01-528-6740	05MH3	NS-P1B-30J	.SWITCH,VALVE MISALI	1
9	PAFZZ	5331-01-528-6701	1BZ02	2614015800	.O-RING	6
10	XCFFF		1BZ02	417869329	DIVERSION VALVE ASS	1
11	PAFZZ	4730-01-322-9131	05MH3	P6ME4	.ELBOW 3/8" TUBE X 1/4" MPT	1
12	PAFZZ	4730-01-322-9129	93061	P6MC4	.CONNECTOR 3/8" TUBE X 1/4" MPT	1
13	PAFZZ	4730-01-322-9129	93061	P6MC4	.CONNECTOR 3/8" TUBE X 1/4" MPT	1
14	PAFZZ	4730-01-527-5883	61424	P6MC8	.CONNECTOR	1
15	PAFZZ	4730-01-528-6743	05MH3	TCN 404	.NIPPLE,NYLON,1/2"	1
16	PAFZZ	4810-01-528-6745	1BZ02	1401095998	.VALVE,SOLENOID	2
17	XCFFF		05MH3	429761260	FLOW METER ASSEMBLY	1
18	MFFZZ		05MH3	PH EB-86-12 IN	.TUBING (MAKE FROM PN PH EB-86)	1
19	MFFZZ		05MH3	PH EB-64-24 IN	.TUBING (MAKE FROM PN PH EB-64)	1
20	PAFZZ	4730-01-322-9131	05MH3	P6ME4	.ELBOW 3/8" TUBE X 1/4" MPT	1
21	PAFZZ	5305-01-528-6765	39428	91802A827	.SCREW,MACHINE	1
22	XCOFF		05MH3	473621943	PRODUCT PRESSURE AS	1
23	PAFZZ	4620-01-468-6275	1BZ02	B511080001	.PROBE,SALINITY	2
24	PAOZZ	4720-01-531-6785	05MH3	KURI3130C1/2	HOSE	1
25	PAOZZ	4730-01-528-5811	05MH3	8 SSHC	.CLAMP,HOSE,#8 SS	10
26	PAOZZ	4730-01-060-6151	05MH3	SS-600-SET	.SLEEVE,COMPRESSION	10
27	PAOZZ	4730-01-060-6150	05MH3	SS-400-SET	.SLEEVE,COMPRESSION	10
28	PAOZZ	4730-01-528-8640	05MH3	SS-800-SET	.FERREL,COMPRESSION	10
29	PAOOO	4820-01-417-8493	92021	SPB-D1S-A-L	.VALVE,BALL	1
30	KFOZZ		05MH3	SPRTC109	PACKING PART OF KIT P/N SPRTD1-A-1	2

(1) ITEM NO.	(2) SMR CODE	(3) NSN	(4) CAGEC	(5) PART NUMBER	(6) DESCRIPTION AND USABLE ON CODE (UOC)	(7) QTY
31	KFOZZ		05MH3	SPRTD013	GASKET,BODY PART OF KIT P/N SPRTD1-A-1	2
32	KFOZZ		05MH3	SPRTD008	SEAT,VALVE PART OF KIT P/N SPRTD1-A-1	2
33	KFOZZ		05MH3	SPRTD0-3	CAVITY FILLER PART OF KIT P/N SPRTD1-A-1	2
34	PAOOO	4820-01-426-4464	92021	SP-34-2	.VALVE,BALL	7
35	KFOZZ		05MH3	SPRTE109	PACKING PART OF KIT P/N SPRTD1-A-1	2
36	KFOZZ		05MH3	SPRTE013	GASKET,BODY PART OF KIT P/N SPRTD1-A-1	2
37	KFOZZ		05MH3	SPRTE008	SEAT,VALVE PART OF KIT P/N SPRTE1-A-1	2
38	KFOZZ		05MH3	SPRTE0-3	CAVITY FILLER PART OF KIT P/N SPRTD1-A-1	2
39	KFOZZ		05MH3	W888526-5	O-RING,COVER PART OF KIT P/N W888526	1
40	KFOZZ		05MH3	W888526-1	DIAPHRAM PART OF KIT P/N W888526	1
41	KFOZZ		05MH3	W888526-4	O-RING,STEM PART OF KIT P/N W888526	1
42	KFOZZ		05MH3	W888526-7	O-RING,RV SEAT PART OF KIT P/N W888526	1
43	KFOZZ		05MH3	W888526-3	DISC ASSEMBLY PART OF KIT P/N W888526	2
44	KFOZZ		05MH3	W888526-2	DISC PART OF KIT P/N W888526	2
45	KFOZZ		05MH3	W888526-6	O-RING,SEAT PART OF KIT P/N W888526	1
46	PAOZZ		OEHX4	KTK-R-20	FUSE,20 AMP	2
KIT	PAOZZ		05MH3	W888526	.KIT,BACKFLOW PREVEN..... DIAPHRAM (1) 1 - 40 DISC (2) 1 - 44 DISC ASSEMBLY (2) 1 - 43 O-RING,COVER (1) 1 - 39 O-RING,RV SEAT (1) 1 - 42 O-RING,SEAT (1) 1 - 45 O-RING,STEM (1) 1 - 41	1
KIT	PAOZZ	4820-01-473-0988	05MH3	SPRTD1-A-1	..KIT,VALVE REBUILD..... CAVITY FILLER (2) 1 - 33 CAVITY FILLER (2) 1 - 38 GASKET,BODY (2) 1 - 31 GASKET,BODY (2) 1 - 36 PACKING (2) 1 - 35 PACKING (2) 1 - 30 SEAT,VALVE (2) 1 - 32	1
KIT	PAOZZ	4820-01-490-2069	05MH3	SPRTE1-A-1	..KIT,VALVE REBUILD..... SEAT,VALVE (2) 1 - 37	1

End of Figure

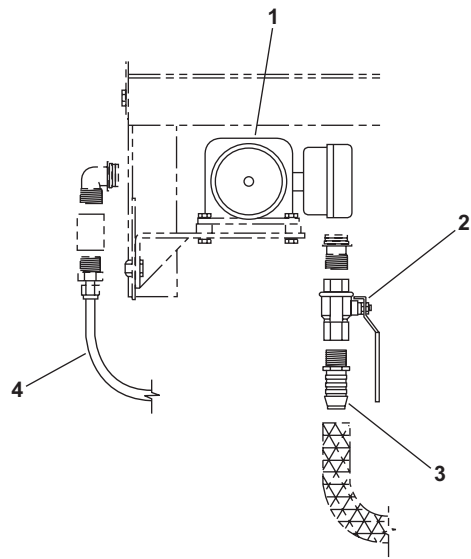

Figure 2. Fresh Water Flush Pump

(1)	(2)	(3)	(4)	(5)	(6)	(7)
ITEM NO.	SMR CODE	NSN	CAGEC	PART NUMBER	DESCRIPTION AND USABLE ON CODE (UOC)	QTY
					GROUP 05160401	
					FIG. 2 FRESH WATER FLUSH PUMP	
1	PAOZZ	4320-01-528-8738	31425	31620-0094	PUMP,4.3 GPM PAR MAX 4 24V PUMP	1
2	XDOZZ		05MH3	SX13176	VALVE,BALL	1
3	PAOZZ	4730-01-528-6811	05MH3	TN64	BARB,NYLON 3/4' NYLON X 1/2" MPT	4
4	MOOZZ		05MH3	3/8049316SMLS-12 "-180"	TUBING (MAKE FROM PN 3/8048316SMLS) ..	1
					End of Figure	

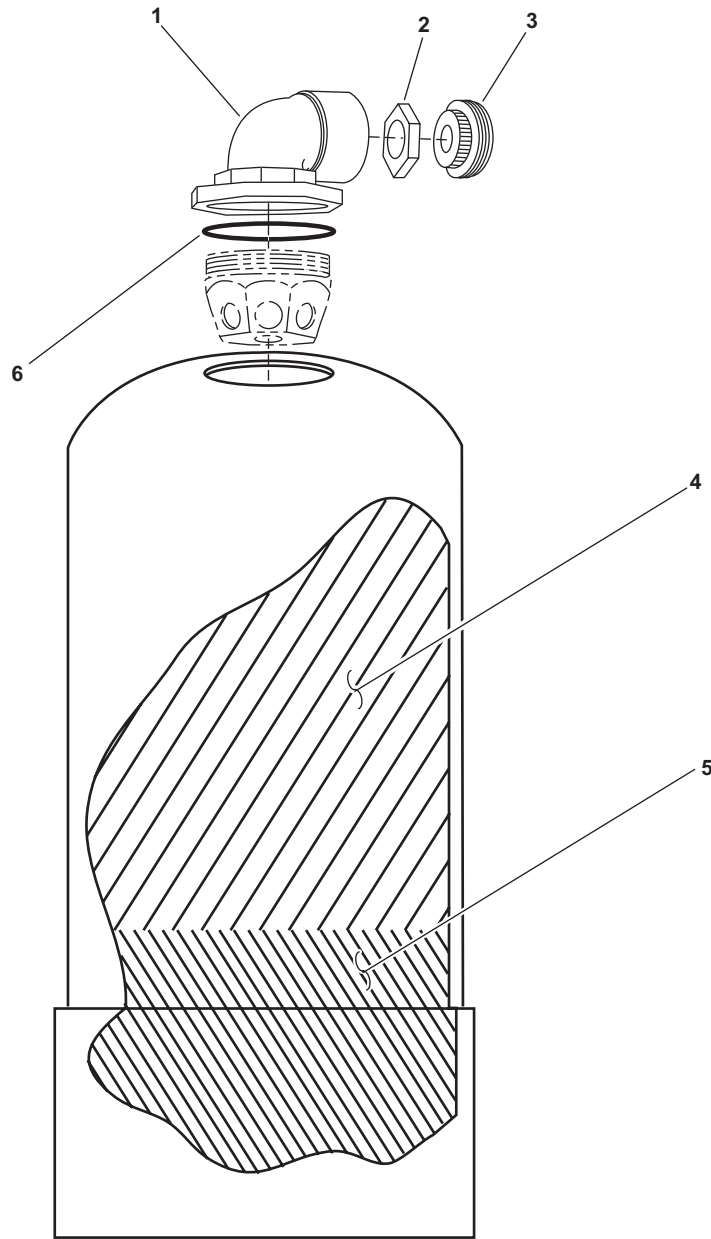

Figure 3. Media Filter Assembly

(1)	(2)	(3)	(4)	(5)	(6)	(7)
ITEM NO.	SMR CODE	NSN	CAGEC	PART NUMBER	DESCRIPTION AND USABLE ON CODE (UOC)	QTY
					GROUP 05160402	
					FIG. 3 MEDIA FILTER ASSEMBLY	
1	XDOZZ		1BZ02	0725100400-01	ELBOW	1
2	PAOZZ		1BZ02	0101326383	BUSHING	1
3	PAOZZ		1BZ02	0101694483	UNION	1
4	PAOZZ	5610-01-407-3130	1BZ02	4643070155	MEDIA,GARNET 8-12	1
5	PAOZZ	5640-01-532-6919	1BZ02	4643020255	SAND,MEDIA,100 LB.	2
6	KFOZZ	5331-00-582-7084	25184	334-7407	O-RING	4
					End of Figure	

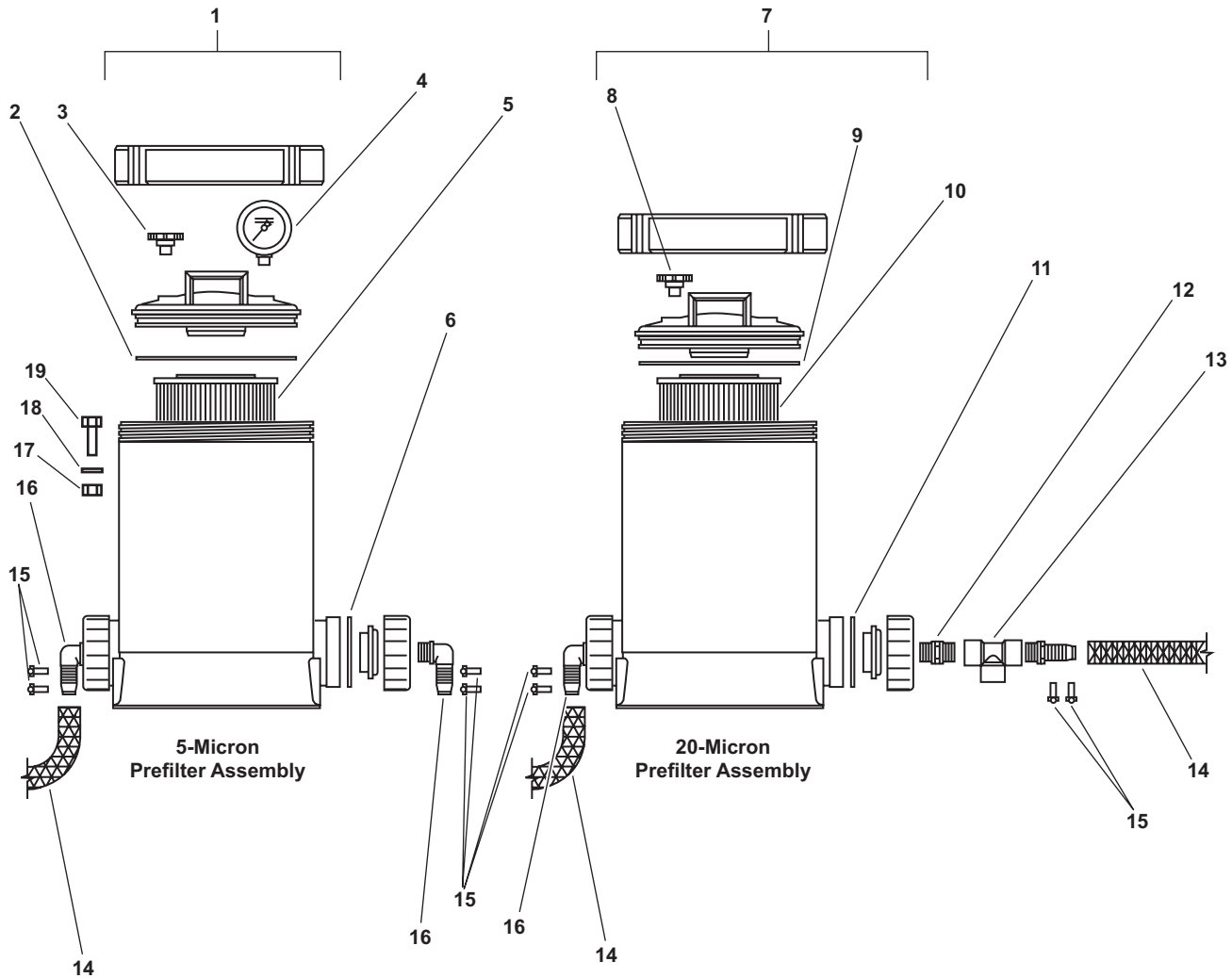

Figure 4. Prefilter Assembly

(1)	(2)	(3)	(4)	(5)	(6)	(7)
ITEM NO.	SMR CODE	NSN	CAGEC	PART NUMBER	DESCRIPTION AND USABLE ON CODE (UOC)	QTY
					GROUP 05160403	
					FIG. 4 PREFILTER ASSEMBLY	
1	PAOOO		05MH3	286432012	PREFILTER ASSEMBLY	1
2	PAOZZ	5331-01-528-6654	1BZ02	07620301WA-06	.O-RING	2
3	PAOZZ	4310-01-528-6651	1BZ02	07620301WA-05	.SCREW,BLEED,PREFILT	2
4	PAOZZ	6685-01-528-6695	1BZ02	10180103CC	.GAUGE,PRESSURE	1
5	PAOZZ		1BZ02	0801063057	.FILTER ELEMENT FLUI PREFILTER 5 MICRON	1
6	PAOZZ	5331-01-528-6661	1BZ02	2614014900	.O-RING	1
7	PAOOO		05MH3	286432011	PREFILTER ASSEMBLY	1
8	PAOZZ	4310-01-528-6651	1BZ02	07620301WA-05	.SCREW,BLEED,PREFILT	2
9	PAOZZ	5331-01-528-6654	1BZ02	07620301WA-06	.O-RING CPF PREFILTER LID	2
10	PAOZZ	4330-01-528-6657	1BZ02	0801143157	.FILTER ELEMENT, FLU PREFILTER 20 MICRON	1
11	PAOZZ	5331-01-528-6661	1BZ02	2614014900	.O-RING	1
12	PAOZZ	4730-01-528-6670	05MH3	TCN 606	.NIPPLE,NYLON,3/4"	4
13	PAOZZ	4730-01-528-6671	05MH3	TTT 34	.TEE,NYLON,3/4" FPT	4
14	XDOZZ	4720-01-531-6788	05MH3	KURI3130D3/4	.HOSE 3/4" CLEAR BRAIDED	1
15	XDOZZ		1BZ02	05181434AA	.CLAMP,HOSE,3/4" SS	4
16	PAOZZ	4730-00-251-6369	72661	TLS66	.ELBOW 3/4" NYLON BARB X 3/4" MPT	1
17	PAOZZ	5310-01-504-5702	39428	90715A125	.NUT,SELF-LOCKING,HE	8
18	PAOZZ	5310-01-464-8148	39428	91525A120	WASHER,FLAT	8
19	PAOZZ	5305-01-528-6392	39428	93190A542	SCREW,CAP,HEXAGON H	8
					End of Figure	

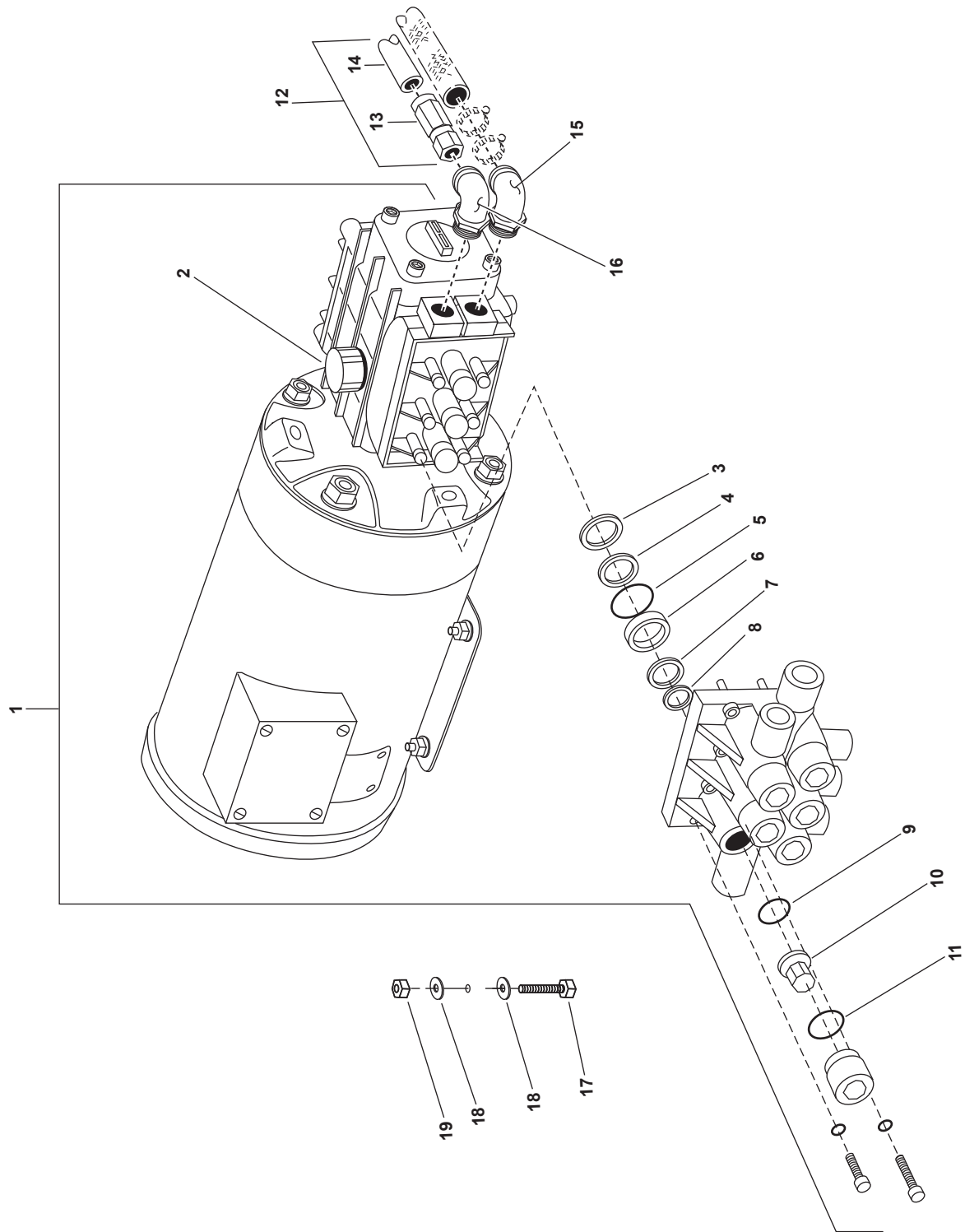

Figure 5. High Pressure Pump

(1)	(2)	(3)	(4)	(5)	(6)	(7)
ITEM NO.	SMR CODE	NSN	CAGEC	PART NUMBER	DESCRIPTION AND USABLE ON CODE (UOC)	QTY
					GROUP 05160404	
					FIG. 5 HIGH PRESSURE PUMP	
1	PAOFF		05MH3	12180512CO	HIGH PRESSURE PUMP	1
2	PAOZZ	5342-01-469-8619	1BZ02	12180510CO-10	..CAP,FILLER OPENING	1
3	KFFZZ		1BZ02	12180510CO-30	RETAINER,SEAL PART OF KIT P/N B652090002	3
4	KFFZZ		1BZ02	12180510CO-31	SEAL,LOW PRESSURE PART OF KIT P/N B652090002	3
5	KFFZZ		1BZ02	12180510CO-32	O-RING,SEAL CASE PART OF KIT P/N B652090002	3
6	KFFZZ		1BZ02	12180510CO-33	SEAL CASE PART OF KIT P/N B652090002	3
7	KFFZZ		1BZ02	12180510CO-34	SQUARE RING,HP SEAL PART OF KIT P/N B652090002	3
8	KFFZZ		1BZ02	12180510CO-35	GLIDE RING,HP SEAL PART OF KIT P/N B652090002	3
9	KFFZZ		1BZ02	12180510CO-40	O-RING,VALVE SPACER PART OF KIT P/N B652090002	6
10	PAFZZ		1BZ02	12180513CO-52	.VALVE ASSEMBLY	6
11	KFFZZ		1BZ02	12180510CO-44	O-RING,VALVE PLUG PART OF KIT P/N B652090002	6
12	XDHHH		05MH3	452679403	HOSE ASSY,HIGH PRES Make from PN: AH40250-6-6 and STO6-6-16-33 IN.....	1
13	PAHZZ	4730-01-528-5084	05MH3	AH40250-6-6	.SWIVEL	2
14	MHHHH		05MH3	ST06-6-16-33 IN	.HOSE,HIGH PRESSURE MAKE FROM PN ST06-6	1
15	PAOZZ	4730-01-122-8918	19139	538429	ELBOW	4
16	PAOZZ	4730-01-528-6634	1BZ02	1317121969	ELBOW	2
17	PAOZZ	5305-01-508-6037	39428	93190A583	SCREW,CAP,HEXAGON H	4
18	PAOZZ	5310-01-528-6401	39428	91950A030	WASHER,FLAT	12
19	PAOZZ	5310-01-523-9885	3A054	90715A135	NUT,LOCK	4
KIT	PAFZZ	5330-01-468-4194	1BZ02	B652090002	.PARTS KIT,SEAL REPL..... GLIDE RING,HP SEAL (3) 5-8 O-RING,SEAL CASE (3) 5-5 O-RING,VALVE PLUG (6) 5-11 O-RING,VALVE SPACER (6) 5-9 RETAINER,SEAL (3) 5-3 SEAL CASE (3) 5-6 SEAL,LOW PRESSURE (3) 5-4 SQUARE RING,HP SEAL (3) 5-7	1

End of Figure

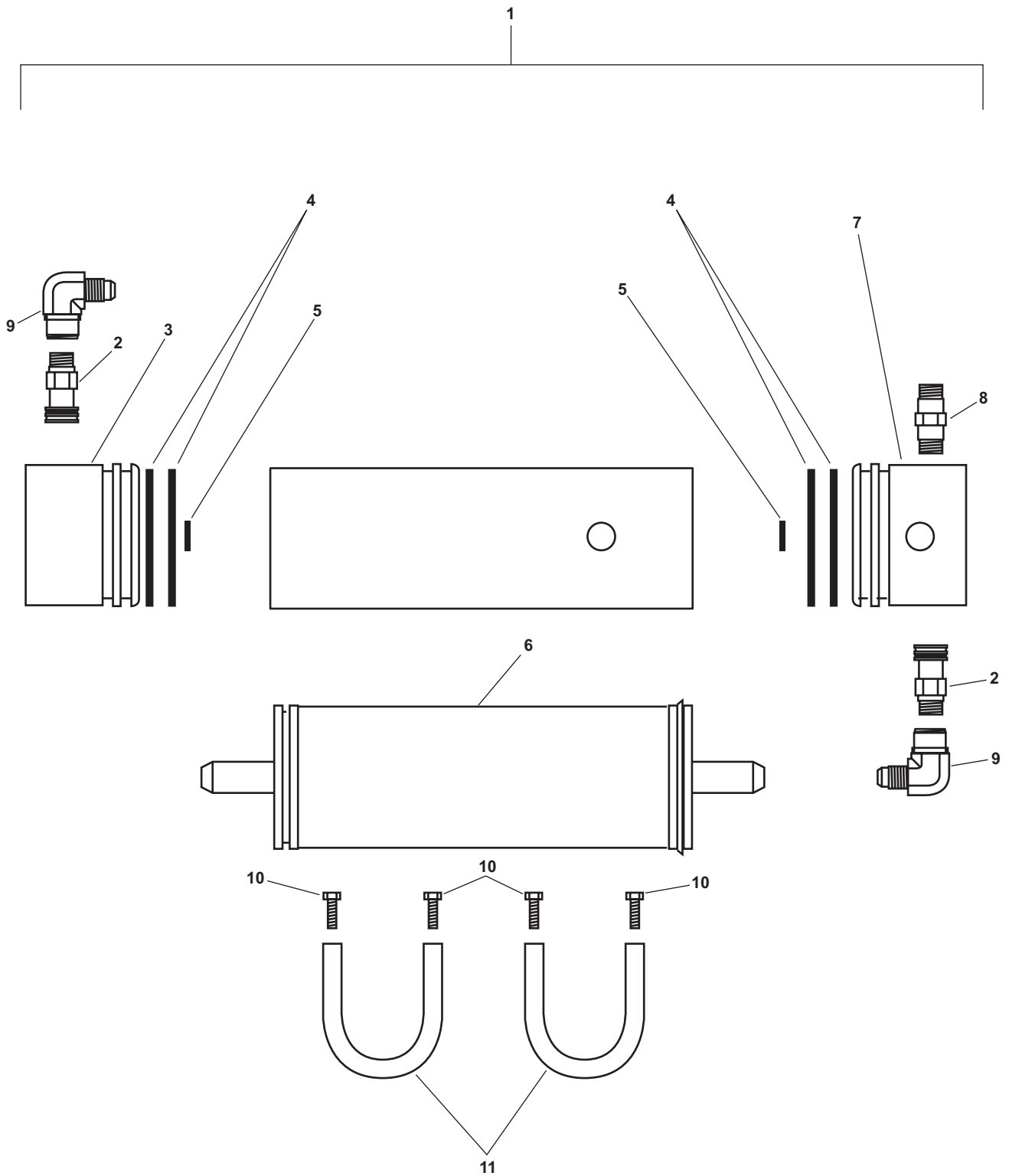

Figure 6. Membrane and Vessel Assembly

(1)	(2)	(3)	(4)	(5)	(6)	(7)
ITEM NO.	SMR CODE	NSN	CAGEC	PART NUMBER	DESCRIPTION AND USABLE ON CODE (UOC)	QTY
					GROUP 05160405	
					FIG. 6 MEMBRANE AND VESSEL ASSEMBLY	
1	XDOOO		1BZ02	523909140	MEMBRANE VESSEL ASS	1
2	PAOZZ	5331-01-528-6709	1BZ02	0117410800	.NIPPLE,HIGH PRESSUR	2
3	PAOZZ	5365-01-528-8637	1BZ02	2453502400	.PLUG,END,SINGLE POR	1
4	PAOZZ	5331-01-528-6661	1BZ02	2614014900	.O-RING CPEE PREFILTER INLET/OUTLET & 3" BRINE	10
5	PAOZZ	5331-01-468-6828	1BZ02	2614010100	.O-RING	4
6	PAOZZ		1BZ02	2724011433	.MEMBRANE	1
7	PAOZZ	4730-01-528-5087	1BZ02	2453512400	.PLUG,END,DOUBLE POR	1
8	PAOZZ	4730-01-528-5094	05MH3	TCN 202	.NIPPLE,NYLON,1/4"	1
9	PAOZZ	4730-01-528-5091	1BZ02	1317011769	.ELBOW 90 DEGREE-6 FLARE X 1/4" FPT SS	2
10	PAOZZ		39428	90585A542	SCREW,CAP,SOCKET HE	4
11	PAOZZ		1BZ02	05202401GR	.BRACKET,U-CLAMP	2
					End of Figure	

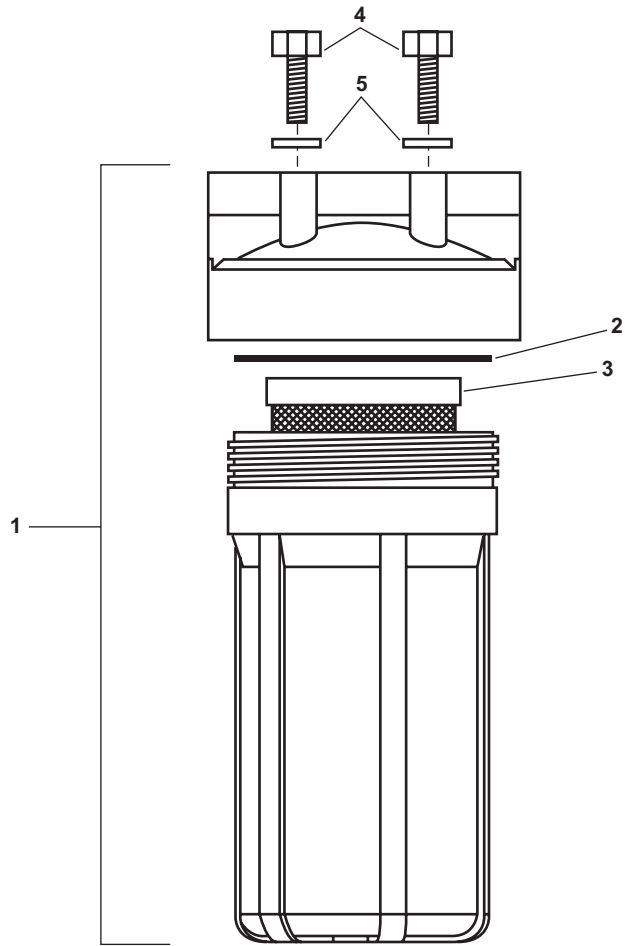

Figure 7. Charcoal Filter

(1)	(2)	(3)	(4)	(5)	(6)	(7)
ITEM NO.	SMR CODE	NSN	CAGEC	PART NUMBER	DESCRIPTION AND USABLE ON CODE (UOC)	QTY
					GROUP 05160406	
					FIG. 7 CHARCOAL FILTER	
1	XCOHH		1BZ02	721453798	10 MICRON FILTER AS	1
2	PAOZZ	5331-01-468-6835	1BZ02	2614010500	.O-RING BIG BLUE FWF HOUSING	2
3	PAOZZ	4330-01-503-3219	05MH3	32-425-125-975	.BRIQUETTE,CARBON FWF 10 MICRON	2
4	XDHZZ		05MH3	SX42854	BOLT,5/16 X 1-1/4	8
5	XDHZZ		05MH3	SX43115	WASHER,FLAT	8
					End of Figure	

(1)	(2)	(3)	(4)	(5)	(6)	(7)
ITEM NO.	SMR CODE	NSN	CAGEC	PART NUMBER	DESCRIPTION AND USABLE ON CODE (UOC)	QTY
					GROUP 95 GENERAL USE STANDARDIZED PARTS	
					GROUP 9501 BULK MATERIAL	
					FIG. 8 BULK	
1	PAOZZ	4720-01-531-6785	05MH3	KURI3130C1/2	HOSE	1
2	PAOZZ	4720-01-531-6788	05MH3	KURI3130D3/4	HOSE	1
3	PAOZZ	4720-01-528-7078	39428	5393K43	TUBE,PVC,WIRE REINF	V
4	PAOZZ	4710-01-528-6731	05MH3	1/2049316SMLS	TUBING	1
5	PAOZZ	4720-01-528-6747	05MH3	PH EB-86	TUBING	V
6	PAFZZ		05MH3	1/4049316SMLS	TUBING,1/4",316SS	10
7	PAOZZ	4720-01-528-6803	05MH3	PH EB-43	TUBING	V
8	PAOZZ	4710-01-528-6805	05MH3	3/8049316SMLS	TUBING	50
9	PAFZZ	4720-01-528-6754	05MH3	PH EB-64	TUBING 3/8" TUBE, POLYE BLACK .062	V
10	PAHZZ	4720-01-528-5085	05MH3	ST06-6	HOSE,HIGH PRESSURE	1
					End of Figure	

NATIONAL STOCK NUMBER INDEX

STOCK NUMBER	FIG.	ITEM	STOCK NUMBER	FIG.	ITEM
4730-00-251-6369	4	16	4710-01-528-6731	8	4
5331-00-582-7084	3	6	5930-01-528-6737	1	5
4730-01-060-6150	1	27	6685-01-528-6740	1	8
4730-01-060-6151	1	26	4730-01-528-6743	1	15
4730-01-122-8918	5	15	4810-01-528-6745	1	16
4730-01-322-9129	1	12	4720-01-528-6747	8	5
	1	13	4720-01-528-6754	8	9
4730-01-322-9131	1	11	5305-01-528-6765	1	21
	1	20	4720-01-528-6803	8	7
5610-01-407-3130	3	4	4710-01-528-6805	8	8
4820-01-417-8493	1	29	4730-01-528-6811	2	3
4820-01-426-4464	1	34	4720-01-528-7078	8	3
5310-01-464-8148	4	18	5365-01-528-8637	6	3
5330-01-468-4194	5	KIT	4730-01-528-8640	1	28
4620-01-468-6275	1	23	4320-01-528-8738	2	1
5331-01-468-6828	6	5	5331-01-528-6661	4	6
5331-01-468-6835	7	2		4	11
5342-01-469-8619	5	2		6	4
4820-01-473-0988	1	KIT	4730-01-528-6670	4	12
4820-01-490-2069	1	KIT	4730-01-528-6671	4	13
4330-01-503-3219	7	3	6685-01-528-6695	4	4
5310-01-504-5702	4	17	5331-01-528-6701	1	3
5305-01-508-6037	5	17		1	6
5310-01-523-9885	5	19		1	9
4730-01-527-5883	1	14	5930-01-528-6706	1	2
4730-01-528-5084	5	13	5331-01-528-6709	6	2
4720-01-528-5085	8	10	4710-01-528-6731	8	4
4730-01-528-5087	6	7	5930-01-528-6737	1	5
4730-01-528-5091	6	9	6685-01-528-6740	1	8
4730-01-528-5094	6	8	4730-01-528-6743	1	15
4730-01-528-5811	1	25	4810-01-528-6745	1	16
5305-01-528-6392	4	19	4720-01-528-6747	8	5
5310-01-528-6401	5	18	4720-01-528-6754	8	9
4730-01-528-6634	5	16	5305-01-528-6765	1	21
4310-01-528-6651	4	3	4720-01-528-6803	8	7
	4	8	4710-01-528-6805	8	8
5331-01-528-6654	4	2	4730-01-528-6811	2	3
	4	9	4720-01-528-7078	8	3
4330-01-528-6657	4	10	5365-01-528-8637	6	3
5331-01-528-6661	4	6	4730-01-528-8640	1	28
	4	11	4320-01-528-8738	2	1
	6	4	4720-01-531-6785	1	24
4730-01-528-6670	4	12		8	1
4730-01-528-6671	4	13	4720-01-531-6788	4	14
6685-01-528-6695	4	4		8	2
5331-01-528-6701	1	3	5640-01-532-6919	3	5
	1	6			
	1	9			
5930-01-528-6706	1	2			
5331-01-528-6709	6	2			

PART NUMBER INDEX

PART NUMBER	FIG.	ITEM	PART NUMBER	FIG.	ITEM
0101326383	3	2	429761260	1	17
0101694483	3	3	437513061	1	7
0117410800	6	2	442909384	1	1
05181434AA	4	15	452679403	5	12
05202401GR	6	11	4643020255	3	5
0725100400-01	3	1	4643070155	3	4
07620301WA-05	4	3	468398210	1	4
	4	8	473621943	1	22
07620301WA-06	4	2	523909140	6	1
	4	9	538429	5	15
0801063057	4	5	5393K43	8	3
0801143157	4	10	721453798	7	1
1/2049316SMLS	8	4	8 SSHC	1	25
1/4049316SMLS	8	6	90585A542	6	10
10180103CC	4	4	90715A125	4	17
12180510CO-10	5	2	90715A135	5	19
12180510CO-30	5	3	91525A120	4	18
12180510CO-31	5	4	91802A827	1	21
12180510CO-32	5	5	91950A030	5	18
12180510CO-33	5	6	93190A542	4	19
12180510CO-34	5	7	93190A583	5	17
12180510CO-35	5	8	AH40250-6-6	5	13
12180510CO-40	5	9	B511080001	1	23
12180510CO-44	5	11	B652090002	5	KIT
12180512CO	5	1	KTK-R-20	1	46
12180513CO-52	5	10	KURI3130C1/2	1	24
1317011769	6	9		8	1
1317121969	5	16	KURI3130D3/4	4	14
1401095998	1	16		8	2
2301020658	1	5	NS-P1B-30J	1	8
2321020458	1	2	P6MC4	1	12
2453502400	6	3		1	13
2453512400	6	7	P6MC8	1	14
2614010100	6	5	P6ME4	1	11
2614010500	7	2		1	20
2614014900	4	6	PH EB-43	8	7
	4	11	PH EB-64	8	9
	6	4	PH EB-64-24 IN	1	19
2614015800	1	3	PH EB-86	8	5
	1	6	PH EB-86-12 IN	1	18
	1	9	SP-34-2	1	34
2724011433	6	6	SPB-D1S-A-L	1	29
286432011	4	7	SPRTC109	1	30
286432012	4	1	SPRTD0-3	1	33
3/8049316SMLS	8	8	SPRTD008	1	32
3/8049316SMLS-12" - 180"	2	4	SPRTD013	1	31
31620-0094	2	1	SPRTD1-A-1	1	KIT
32-425-125-975	7	3	SPRTE0-3	1	38
334-7407	3	6	SPRTE008	1	37
417869329	1	10	SPRTE013	1	36

PART NUMBER INDEX (CONTINUED)

PART NUMBER	FIG.	ITEM	PART NUMBER	FIG.	ITEM
SPRTE1-A-1	1	KIT	TCN 606	4	12
SPRTE109	1	35	TLS66	4	16
SS-400-SET	1	27	TN64	2	3
SS-600-SET	1	26	TTT 34	4	13
SS-800-SET	1	28	W888526	1	KIT
ST06-6	8	10	W888526-1	1	40
ST06-6-16-33 IN	5	14	W888526-2	1	44
SX13176	2	2	W888526-3	1	43
SX42854	7	4	W888526-4	1	41
SX43115	7	5	W888526-5	1	39
TCN 202	6	8	W888526-6	1	45
TCN 404	1	15	W888526-7	1	42

END OF WORK PACKAGE

**OPERATOR, UNIT, DIRECT SUPPORT, AND GENERAL SUPPORT MAINTENANCE
REVERSE OSMOSIS WATER PURIFICATION UNIT FOR
INLAND AND COASTAL LARGE TUG (LT)
COMPONENTS OF END ITEM (COEI) AND BASIC ISSUE ITEMS (BII) LISTS**

INTRODUCTION

SCOPE

This work package lists COEI and BII for the Reverse Osmosis Water Purification Unit (ROWPU) for the Inland and Coastal Large Tug (LT) to help you inventory items for safe and efficient operation of the equipment.

GENERAL

The COEI and BII information is divided into the following lists:

Components of End Item (COEI). This list is for information purposes only and is not authority to requisition replacements. These items are part of the ROWPU for the Large Tug (LT). As part of the end item, these items must be with the end item whenever it is issued or transferred between property accounts. Items of COEI are removed and separately packaged for transportation or shipment only when necessary. Illustrations are furnished to help you find and identify the items.

Basic Issue Items (BII). These essential items are required to place the ROWPU for Large Tug (LT) in operation, operate it, and to do emergency repairs. Although shipped separately packaged, BII must be with the ROWPU for the Large Tug (LT) during operation and when it is transferred between property accounts. Listing these items is your authority to request/requisition them for replacement based on authorization of the end item by the TOE/MTOE. Illustrations are furnished to help you find and identify the items.

EXPLANATION OF COLUMNS IN THE COEI LIST AND BII LIST

Column (1) Illus Number. Gives you the number of the item illustrated.

Column (2) National Stock Number (NSN). Identifies the stock number of the item to be used for requisitioning purposes.

Column (3) Description, CAGEC, and Part Number. Identifies the Federal item name (in all capital letters) followed by a minimum description when needed. The stowage location of COEI and BII is also included in this column. The last line below the description is the CAGEC (Commercial and Government Entity Code) (in parentheses) and the part number.

Column (4) Usable On Code. When applicable, gives you a code if the item you need is not the same for different models of equipment.

Column (5) Unit of Issue (U/I). Indicates the physical measurement or count of the item as issued per the National Stock Number shown in column (2).

Column (6) Qty Rqr. Indicates the quantity required.

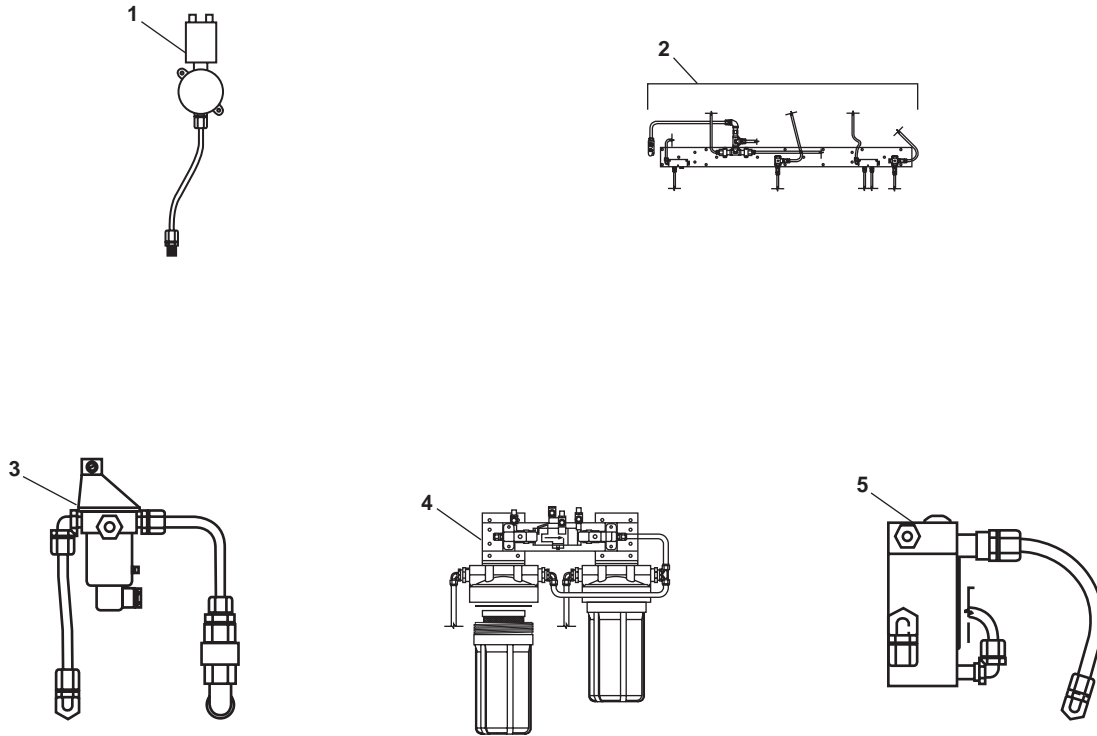

Table 1. Components of End Item List

(1) ILLUS NUMBER	(2) NATIONAL STOCK NUMBER	(3) DESCRIPTION CAGEC, AND PART NUMBER	(4) USABLE ON CODE	(5) U/I	(6) QTY RQR
1		BRINE DISCHARGE PRESSURE ASSEMBLY (AMS2, Port, FWD) (05MH3) 437513061	128	EA	2
2		CROSS MEMBER, VALVE MOUNT (AMS2, Port, FWD) (05MH3) 351102981	128	EA	2
3		DIVERSION VALVE ASSEMBLY (AMS2, Port, FWD) (1BZ02) 417869329	128	EA	2
4		FILTER, CHARCOAL (AMS2, Port, FWD) (1BZ02) 721453798	128	EA	2
5		FLOW METER ASSEMBLY (AMS2, Port, FWD) (05MH3) 429761260	128	EA	2

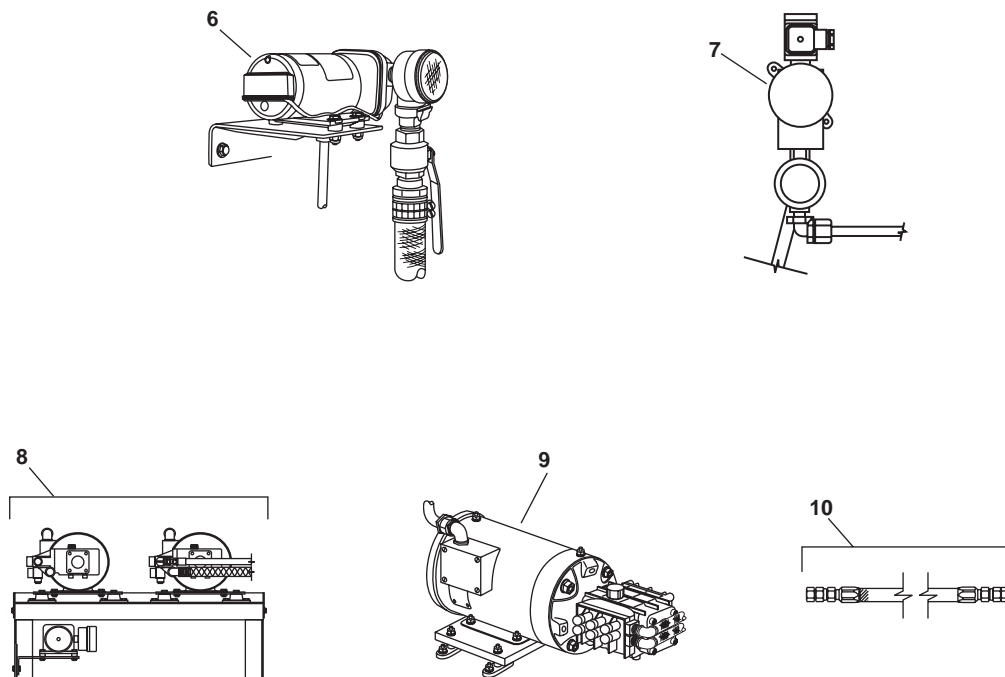

Table 1. Components of End Item List (continued)

(1) ILLUS NUMBER	(2) NATIONAL STOCK NUMBER	(3) DESCRIPTION CAGEC, AND PART NUMBER	(4) USABLE ON CODE	(5) U/I	(6) QTY RQR
6	4320-01-528-8738	FRESH WATER FLUSH PUMP (AMS2, Port, FWD) (31425) 31620-0094	128	EA	1
7		HIGH PRESSURE ASSEMBLY (AMS2, Port, FWD) (05MH3) 442909384	128	EA	2
8		HIGH PRESSURE AND FRESH WATER FLUSH PUMP ASSEMBLY (AMS2,Port,FWD) (05MH3) 432155982	128	EA	2
9		HIGH PRESSURE PUMP ASSEMBLY (AMS2, Port, FWD) (05MH3) 12180512CO	128	EA	2
10		HIGH PRESSURE HOSE ASSEMBLY (AMS2, Port, FWD) (05MH3) 452679403	128	EA	2

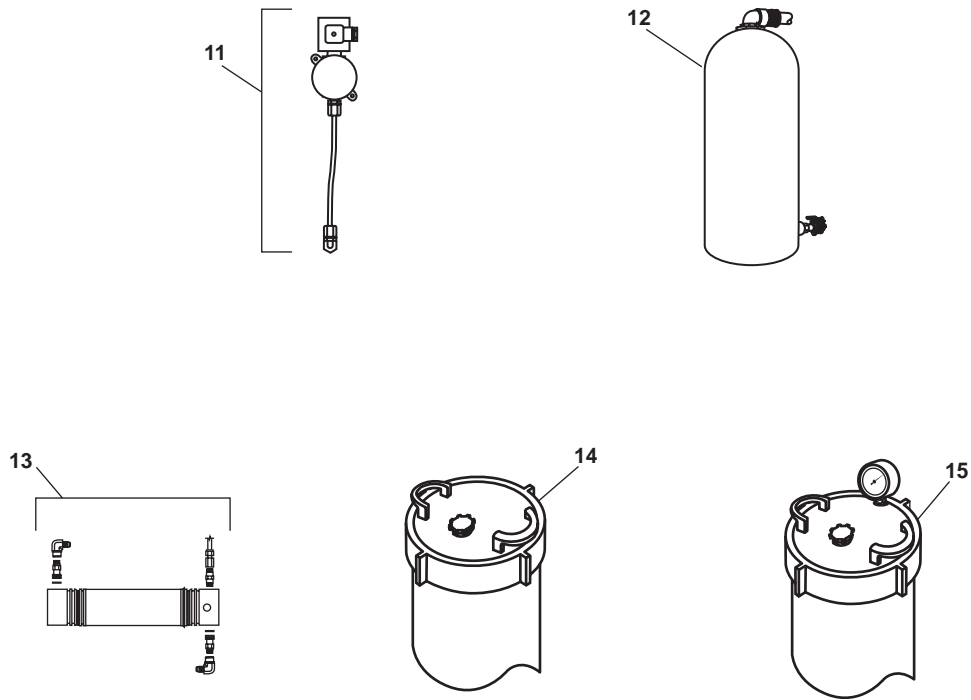

Table 1. Components of End Item List (continued)

(1) ILLUS NUMBER	(2) NATIONAL STOCK NUMBER	(3) DESCRIPTION CAGEC, AND PART NUMBER	(4) USABLE ON CODE	(5) U/I	(6) QTY RQR
11		INLET PRESSURE ASSEMBLY (AMS2, Port, FWD) (05MH3) 468398210	128	EA	2
12		MEDIA FILTER ASSEMBLY (AMS2, Port, FWD) (1BZ02) B071080002	128	EA	1
13		MEMBRANE VESSEL ASSEMBLY (AMS2, Port, FWD) (1BZ02) 523909140	128	EA	3
14		PREFILTER ASSEMBLY (20 MICRON) (AMS2, Port, FWD) (05MH3) 286432011	128	EA	2
15		PREFILTER SUB-ASSEMBLY (5 MICRON) (AMS2, Port, FWD) (05MH3) 286432012	128	EA	2

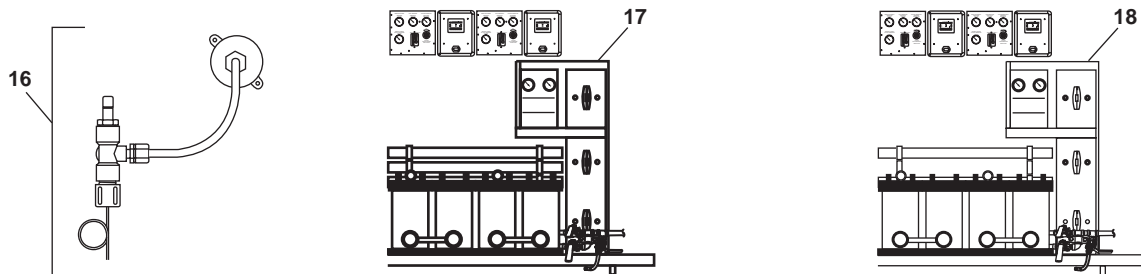

Table 1. Components of End Item List (continued)

(1) ILLUS NUMBER	(2) NATIONAL STOCK NUMBER	(3) DESCRIPTION CAGEC, AND PART NUMBER	(4) USABLE ON CODE	(5) U/I	(6) QTY RQR
16		PRODUCT PRESSURE ASSEMBLY (AMS2, Port, FWD) (05MH3) 473621943	128	EA	2
17		REVERSE OSMOSIS WATER MAKER, 1500 GPD (AMS2, Port, Forward) (1BZ02) SRC AW 1500MS-2	128	EA	1
18		REVERSE OSMOSIS WATER MAKER, 800 GPD (AMS2, Port, Forward) (1BZ02) SRC AW 800MS-1	128	EA	1

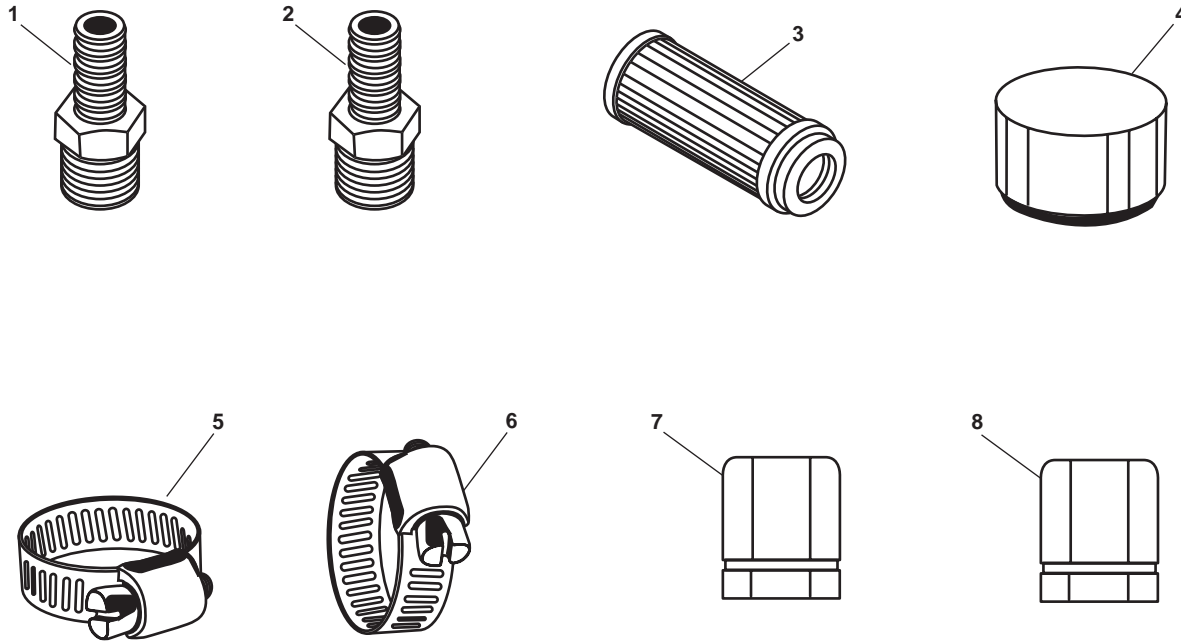

Table 2. On Board Spares List

(1) ILLUS NUMBER	(2) NATIONAL STOCK NUMBER	(3) DESCRIPTION CAGEC, AND PART NUMBER	(4) USABLE ON CODE	(5) U/I	(6) QTY RQR
1	4730-01-528-6811	BARB, NYLON (vestibule VIDMAR cabinets) (05MH3) TN 64	128	EA	4
2	4730-01-130-5438	BARB, NYLON (vestibule VIDMAR cabinets) (72661) TN-66	128	EA	4
3	4330-01-503-3219	BRIQUETTE, CARBON (AMS 2) (62144) 33-0315	128	EA	6
4	5342-01-469-8619	CAP, OIL, VENTED (vestibule VIDMAR cabinets) (1BZ02) 12180510CO-10	128	EA	1
5		CLAMP, HOSE SS, #12 (vestibule VIDMAR cabinets) (05MH3) #12 SSHC	128	EA	10
6	4730-01-528-5811	CLAMP, HOSE, #8 SS (vestibule VIDMAR cabinets) (05MH3) #8 SSHC	128	EA	10
7	4730-01-322-9129	CONNECTOR (vestibule VIDMAR cabinets) (93061) P6MC4	128	EA	1
8	4730-01-527-5883	CONNECTOR (vestibule VIDMAR cabinets) (61424) P6MC8	128	EA	1

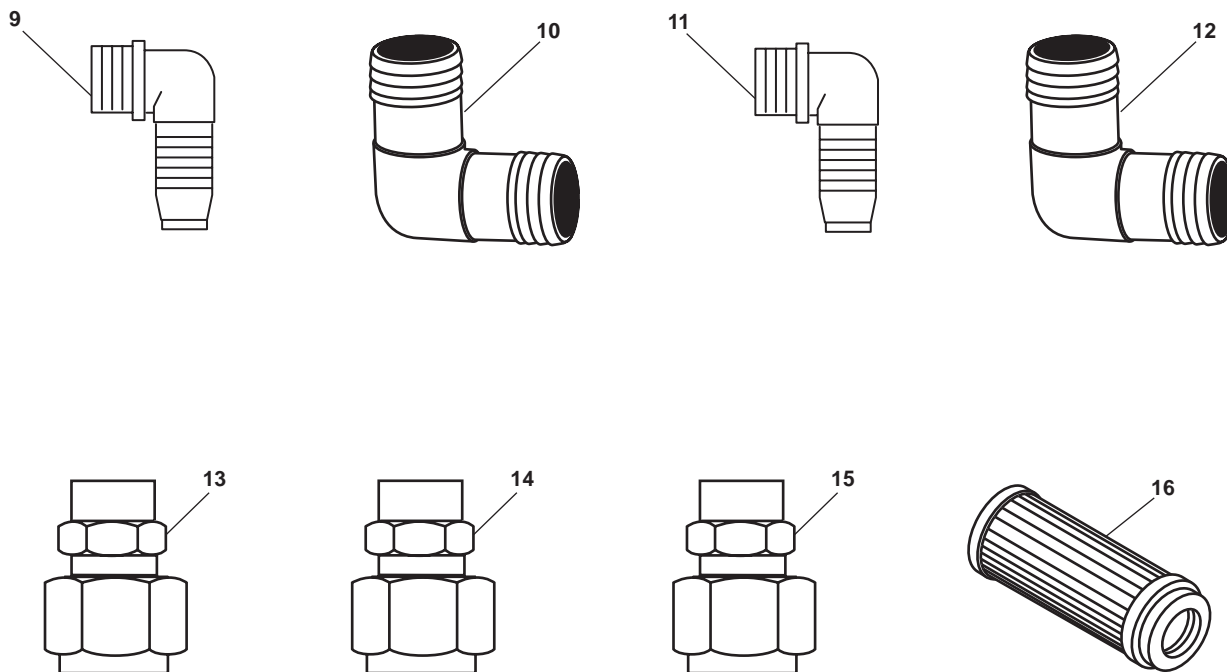

Table 2. On Board Spares List (continued)

(1) ILLUS NUMBER	(2) NATIONAL STOCK NUMBER	(3) DESCRIPTION CAGEC, AND PART NUMBER	(4) USABLE ON CODE	(5) U/I	(6) QTY RQR
9	4730-01-322-9131	ELBOW (vestibule VIDMAR cabinets) (93061) P6ME4	128	EA	1
10	4730-01-122-8918	ELBOW (vestibule VIDMAR cabinets) (19139) 538429	128	EA	4
11	4730-00-251-6369	ELBOW (vestibule VIDMAR cabinets) (72661) TLS66	128	EA	4
12	4730-01-528-5091	ELBOW (vestibule VIDMAR cabinets) (1BZ02) 1317011769	128	EA	2
13	4730-01-528-8640	FERRULE SET, 1/2 (vestibule VIDMAR cabinets) (05MH3) SS-800-SET	128	EA	10
14	4730-01-060-6150	FERRULE SET, 1/4 (vestibule VIDMAR cabinets) (02570) SS-400-SET	128	EA	10
15	4730-01-060-6151	FERRULE SET, 3/8 (vestibule VIDMAR cabinets) (02570) SS-600-SET	128	EA	10
16	4330-01-468-8072	FILTER ELEMENT, FLUID (vestibule VIDMAR cabinets) (1BZ02) 0801063057	128	EA	12

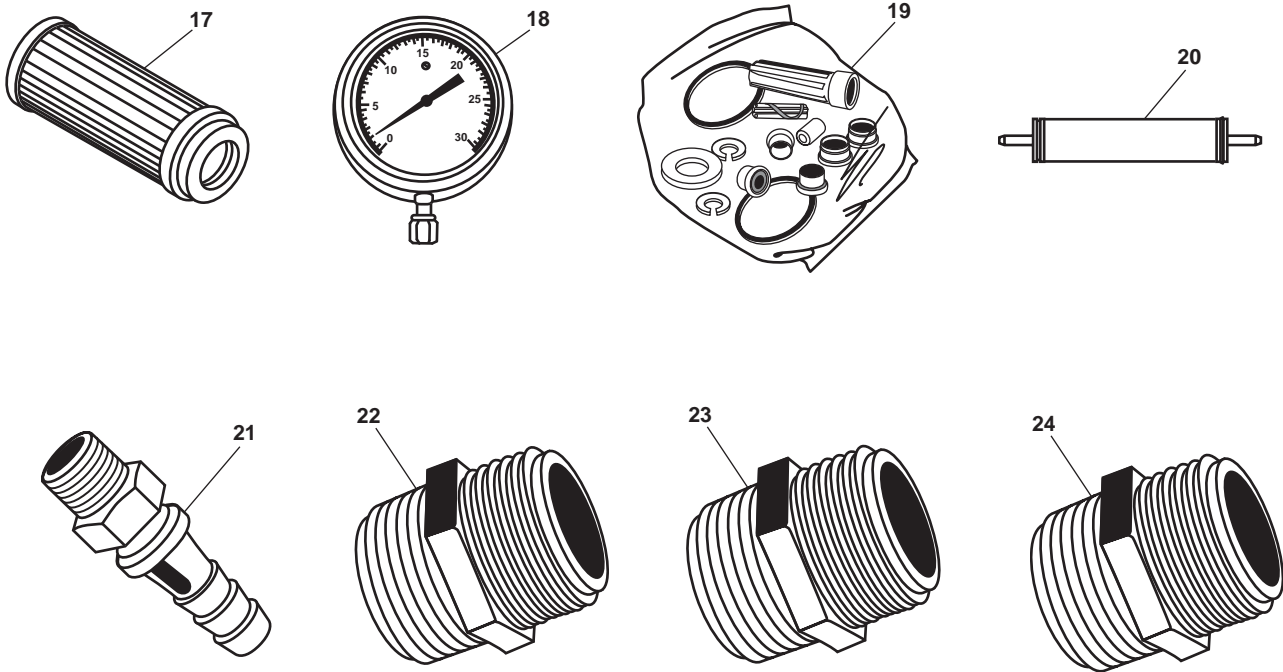

Table 2. On Board Spares List (continued)

(1) ILLUS NUMBER	(2) NATIONAL STOCK NUMBER	(3) DESCRIPTION CAGEC, AND PART NUMBER	(4) USABLE ON CODE	(5) U/I	(6) QTY RQR
17	4330-01-528-6657	FILTER ELEMENT, FLUID (vestibule VIDMAR cabinets) (1BZ02) 0801143157	128	EA	12
18	6685-01-528-6695	GAUGE, PRESSURE (bosun's locker) (1BZ02) 10180103CC	128	EA	2
19		KIT, BACKFLOW PREVENTER (bosun's locker) (05MH3) W888526	128	KT	1
20		MEMBRANE, 900 GPD SW, 40" (bow thruster compartment) (1BZ02) 2724011433	128	EA	1
21	5331-01-528-6709	NIPPLE, HIGH PRESSURE (vestibule VIDMAR cabinets) (1BZ02) 0117410800	128	EA	6
22	4730-01-528-6743	NIPPLE, NYLON, 1/2" (vestibule VIDMAR cabinets) (05MH3) TCN 404	128	EA	1
23	4730-01-528-5094	NIPPLE, NYLON, 1/4 (vestibule VIDMAR cabinets) (05MH3) TCN-202	128	EA	10
24	4730-01-528-6670	NIPPLE, NYLON, 3/4" (vestibule VIDMAR cabinets) (05MH3) TCN 606	128	EA	4

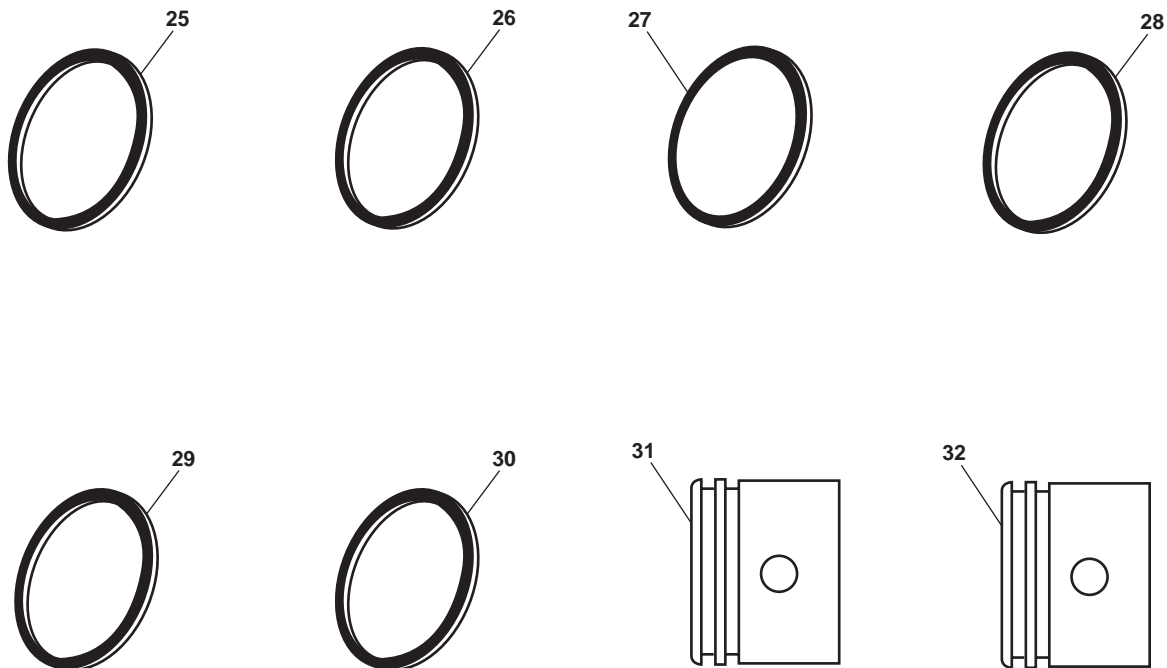

Table 2. On Board Spares List (continued)

(1) ILLUS NUMBER	(2) NATIONAL STOCK NUMBER	(3) DESCRIPTION CAGEC, AND PART NUMBER	(4) USABLE ON CODE	(5) U/I	(6) QTY RQR
25	5331-01-528-6654	O-RING (vestibule VIDMAR cabinets) (1BZ02) 07620301WA-06	128	EA	2
26	5331-01-528-6661	O-RING (vestibule VIDMAR cabinets) (1BZ02) 2614014900	128	EA	8
27	5331-01-528-6701	O-RING (vestibule VIDMAR cabinets) (1BZ02) 2614015800	128	EA	6
28	5331-00-582-7084	O-RING (vestibule VIDMAR cabinets) (25184) 334-7407	128	EA	2
29	5331-01-468-6828	O-RING (vestibule VIDMAR cabinets) (1BZ02) 2614010100	128	EA	4
30	5331-01-468-6835	O-RING (vestibule VIDMAR cabinets) (1BZ02) 2614010500	128	EA	4
31	4730-01-528-5087	PLUG, END, DOUBLE PORT (bow thruster compartment) (1BZ02) 2453512400	128	EA	2
32	5365-01-528-8637	PLUG, END, SINGLE PORT (bow thruster compartment) (1BZ02) 2453502400	128	EA	1

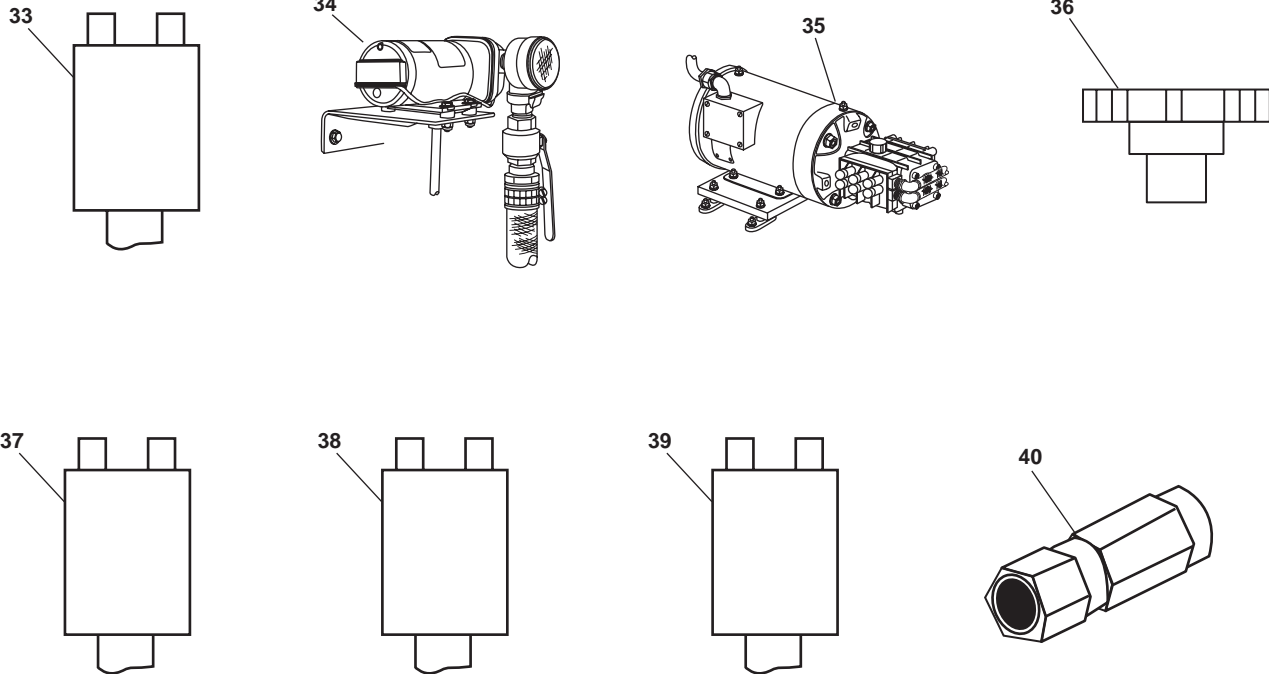

Table 2. On Board Spares List (continued)

(1) ILLUS NUMBER	(2) NATIONAL STOCK NUMBER	(3) DESCRIPTION CAGEC, AND PART NUMBER	(4) USABLE ON CODE	(5) U/I	(6) QTY RQR
33	4620-01-468-6275	PROBE, SALINITY (vestibule VIDMAR cabinets) (1BZ02) B511080001	128	EA	2
34	4320-01-528-8738	PUMP, 4.3 GPM (bow thruster compartment) (31425) 31620-0094	128	EA	1
35	4230-01-472-6430	PUMP, HIGH PRESSURE (bow thruster compartment) (1BZ02) 12180512CO	128	EA	1
36	4310-01-528-6651	SCREW, BLEED, PREFILTER (vestibule VIDMAR cabinets) (1BZ02) 07620301WA-05	128	EA	2
37	5930-01-528-6706	SWITCH, HIGH PRESSUE (vestibule VIDMAR cabinets) (1BZ02) 2321020458	128	EA	1
38	5930-01-528-6737	SWITCH, LOW PRESSURE (vestibule VIDMAR cabinets) (1BZ02) 2301020658	128	EA	1
39	6685-01-528-6740	SWITCH, VALVE MISALIGNMENT (vestibule VIDMAR cabinets) (05MH3) NSP1B30J	128	EA	1
40	4730-01-528-5084	SWIVEL (vestibule VIDMAR cabinets) (05MH5) AH40250-6-6	128	EA	2

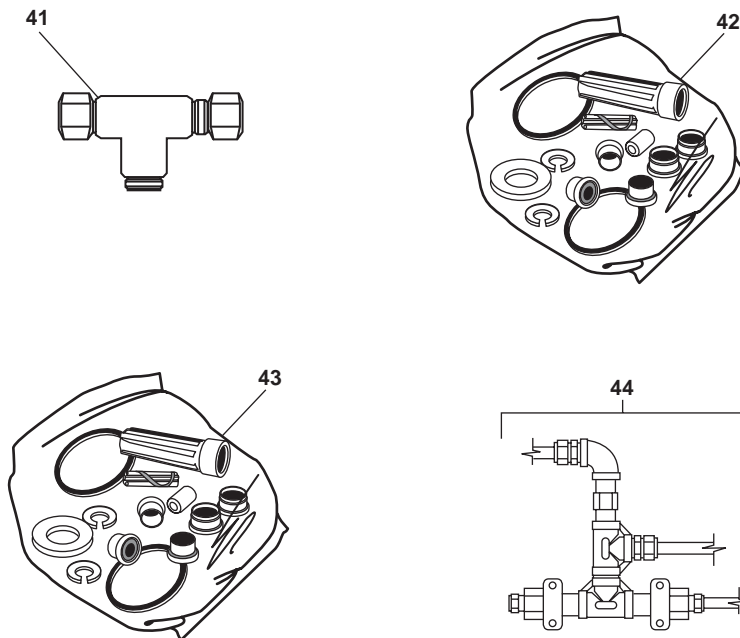

Table 2. On Board Spares List (continued)

(1) ILLUS NUMBER	(2) NATIONAL STOCK NUMBER	(3) DESCRIPTION CAGEC, AND PART NUMBER	(4) USABLE ON CODE	(5) U/I	(6) QTY RQR
41	4730-01-528-6671	TEE, NYLON, 3/4" FPT (vestibule VIDMAR cabinets) (05MH3) TTT 34	128	EA	4
42	4820-01-490-2069	VALVE REBUILD KIT, SIL BRAZE 1 (bosun's locker) (92021) SPRTE1--A--1	128	KT	1
43	4820-01-473-0988	VALVE REBUILD KIT, SIL BRAZE 3/4 (bosun's locker) (92021) SPRTE1--A--1	128	KT	1
44	4810-01-528-6745	VALVE, DIVERSION, PRODUCT WATER AND FRESH WATER FLUSH (bow thruster compartment) (1BZ02) 1401095998	128	EA	2

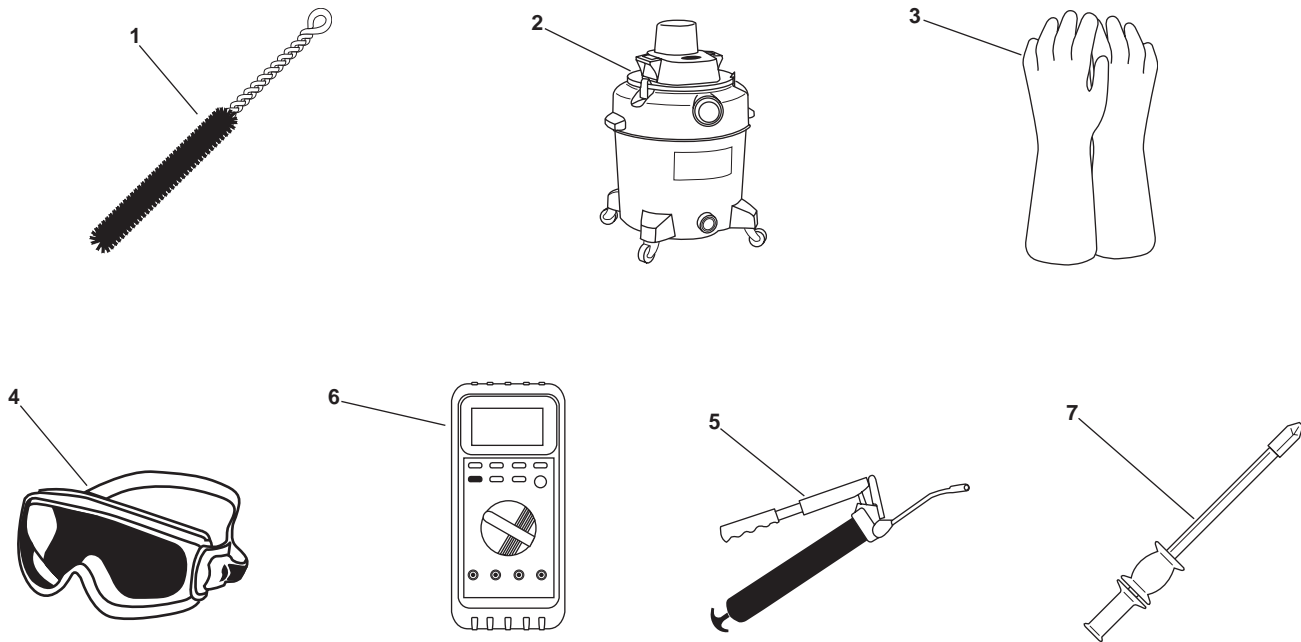

Table 3. Basic Issue Items List

(1) ILLUS NUMBER	(2) NATIONAL STOCK NUMBER	(3) DESCRIPTION CAGEC, AND PART NUMBER	(4) USABLE ON CODE	(5) U/I	(6) QTY RQR
1	7920-00-285-9100	BRUSH, BOTTLE AND BURET (machine shop) (80064) 3153774PC625	128	DZ	1
2	7910-00-550-9120	CLEANER, VACUUM, ELECTRIC (cleaning locker) (80029) MODEL 2815	128	EA	1
3	8415-01-013-7384	GLOVES, CHEMICAL AND OIL PROTECTIVE (bosun's locker) (81349) MIL-G-87066	128	PR	2
4	4240-00-190-6432	GOGGLES, INDUSTRIAL (machine shop) (80204) ANSI Z87.1-1989	128	PR	2
5	4930-00-223-3389	LUBRICATING GUN, HAND (machine shop) (0FKM1) 7584	128	EA	1
6	6625-01-265-6000	MULTIMETER, AN/PSM45A (DC locker) (89536) 27W/ACCE	128	EA	1
7	5120-01-530-7892	SLIDE HAMMER, PACKING EXTRACTION (machine shop) (1BZ02) 45001225CO	128	EA	1

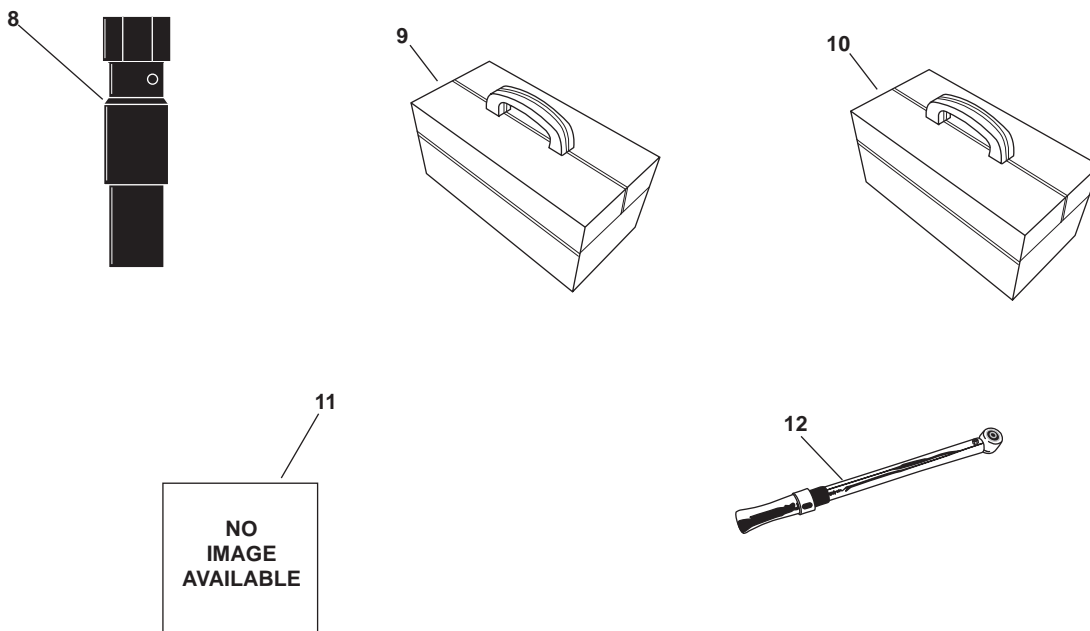

Table 3. Basic Issue Items List (continued)

(1) ILLUS NUMBER	(2) NATIONAL STOCK NUMBER	(3) DESCRIPTION CAGEC, AND PART NUMBER	(4) USABLE ON CODE	(5) U/I	(6) QTY RQR
8		SOCKET, PACKING EXTRACTION, 20MM (machine shop) (1BZ02) 45001205CO	128	EA	1
9	5180-00-313-3045	TOOL KIT, ELECTRICIAN'S (machine shop) (50980) SC5180-90-CL-N35	128	KT	1
10	5180-00-629-9783	TOOL KIT, GENERAL MECHANIC'S (machine shop) (50980) SC5180-90-CL-N55	128	KT	1
11		INTENTIONALLY LEFT BLANK			
12	5120-00-288-8865	WRENCH, TORQUE, 0-600 IN-LB (machine shop) (05047) B107.14M TY1CLBST3	128	EA	1

END OF WORK PACKAGE

**OPERATOR, UNIT, DIRECT SUPPORT, AND GENERAL SUPPORT MAINTENANCE
REVERSE OSMOSIS WATER PURIFICATION UNIT FOR
INLAND AND COASTAL LARGE TUG (LT)
EXPENDABLE AND DURABLE ITEMS LIST**

INTRODUCTION**SCOPE**

This work package lists expendable and durable items that you will need to operate and maintain the reverse osmosis water purification unit for the Inland and Coastal Large Tug (LT). This list is for information only and is not authority to requisition the listed items. These items are authorized to you by CTA 50-970, Expendable/Durable Items (Except Medical, Class V Repair Parts, and Heraldic Items), or CTA 8-100, Army Medical Department Expendable/Durable Items.

EXPLANATION OF COLUMNS IN THE EXPENDABLE/DURABLE ITEMS LIST

Column (1) Item Number. This number is assigned to the entry in the list and is referenced in the narrative instructions to identify the item (e.g., "Use brake fluid (item 5, WP 0098 00).").

Column (2) Level. This column identifies the lowest level of maintenance that requires the listed item (include as applicable: C = Operator/Crew, O = Unit, F = Direct Support, H = General Support, D = Depot).

Column (3) National Stock Number (NSN). This is the NSN assigned to the item, which you can use to requisition it.

Column (4) Item Name, Description, Commercial and Government Entity Code (CAGEC), and Part Number (P/N). This column provides the other information you need to identify the item.

Column (5) Unit of Issue (U/I). Indicates the physical measurement or count of the item as issued per the National Stock Number shown in column (3).

Table 1. Expendable and Durable Items List

(1) ITEM NUMBER	(2) LEVEL	(3) NATIONAL STOCK NUMBER (NSN)	(4) ITEM NAME, DESCRIPTION, CAGEC, AND PART NUMBER	(5) U/I
1	C	6850-01-493-8360	CLEANER, ACID (1BZ02) B645800002	EA
2	C	6850-01-493-8354	CLEANER, ALKALINE (1BZ02) B645800001	EA
3	O	6850-01-493-8355	CLEANER, RUST (1BZ02) B645800004	EA
4	O	8030-00-251-3980	COMPOUND, ANTISEIZE (26916) 034-00750	LB
5	C	6850-00-281-1985	DRY CLEANING SOLVENT (02978) PS661	GL
6	C	9150-01-525-1498	GREASE, POLYREA, ELEC. MTR. (29700) MOBIL POLYREX 14-EMOZ	CN
7	C	4720-01-531-6785	HOSE, BRAIDED, CLEAR, 1/2" (30 FEET) (05MH3) KURI3130C1/2	FT
8	C	4720-01-531-6788	HOSE, BRAIDED, CLEAR, 3/4" (20 FEET) (05MH3) KURI3130D3/4	FT
9	O	4720-01-528-5085	HOSE, HP, -6 (25 FEET) (05MH3) ST06-6	FT
10	C	6810-00-983-8551	ISOPROPYL ALCOHOL, TECHNICAL (83148) TT-I-735	QT
11	C	9150-01-469-7264	LUBRICANT, SILICONE (75906) W46040-111	TU
12	O	5610-01-407-3130	MEDIA GARNET 8-12 (1BZ02) 4643070155	BG
13	C	9150-01-493-8350	PUMP OIL, HP, 2.5 GAL (1BZ02) B647800002	EA
14	C	7920-00-205-1711	RAG,WIPING, 50LB BALE (80244) 7920-00-205-1711	BE
15	C	5610-01-532-6919	SAND, MEDIA, 100 LB. (05MH3) 4643020255	BG
16	O	8030-01-025-1692	SEALING COMPOUND, LOCTITE 242 (81349) MIL-S-46163	BT
17	C		TAG, DANGER (USED FOR LOCKOUT/TAGOUT) (3HPE6) 0116-LF-115-4300	BX
18	C	8030-00-889-3535	TAPE, ANTISEIZING 1/2 IN X 260 IN (96214) 417043-2	EA
19	O	4720-01-528-6803	TUBE, POLYE, BLACK .040, 1/4" (5 FEET) (05MH3) PH EB 43	FT
20	O	4720-01-528-6754	TUBE, POLYE, BLACK .062, 3/8" (5 FEET) (05MH3) PH EB 64	FT
21	O	4720-01-528-6747	TUBE, POLYE, BLACK .062, 1/2" (5 FEET) (05MH3) PH EB 86	FT
22	O	4720-01-528-6731	TUBING, 316 SS, .049, 1/2" (10 FEET) (05MH3) 1/2049316SMLS	FT
23	O	4720-01-528-6805	TUBING, 316 SS, .049, 3/8" (10 FEET) (05MH3) 3/8049316SMLS	FT

END OF WORK PACKAGE

**OPERATOR, UNIT, DIRECT SUPPORT, AND GENERAL SUPPORT MAINTENANCE
REVERSE OSMOSIS WATER PURIFICATION UNIT FOR
INLAND AND COASTAL LARGE TUG (LT)
GLOSSARY**

Brine	Water saturated with or containing large amounts of salt.
Chlorine	Chlorine is a disinfectant which wipes out bacteria and is added to most all municipal water systems.
Desalination	The purification of salt or brackish water by removing the dissolved salts. Desalination is typically accomplished by the ROWPU.
Media Filter	the media filter removes suspended particles 30 micron and larger from the raw water.
Media	The selected materials in a filter that form the barrier to the passage of certain suspended solids or dissolved molecules.
Micron	A linear measure equal to one millionth of a meter, or 0.00003937 inch.
Membrane Elements	Thin films constructed of cellulosic or synthetic materials, which are designed to provide selective transport of solutes. The membrane element is one of the two basic main requirements of the ROWPU.
Osmosis	The natural tendency of water to pass through a semi-permeable membrane, so as to equalize concentrations on both sides of the membrane.
Potable water	Water, which is considered safe and fit for human consumption, culinary, and domestic purposes. Potable water is the end result of the ROWPU.
Raw Water	Untreated water, or any water before it reaches the ROWPU.
ROWPU	Reverse Osmosis Water Purification Unit.
Salinity	Generally, the concentration of mineral salts dissolved in water.
Solutes	A dissolved substance.
Suspended Solids	Particles less than one micron in diameter.
Semi-Permeable	An ultra filtration membrane, which allows the passage of some molecules and prevents the passage of others.
Total Dissolved Solids (TDS)	In drinking water, a measure of calcium, magnesium, and other dissolved mineral salts.

END OF WORK PACKAGE

**OPERATOR, UNIT, DIRECT SUPPORT, AND GENERAL SUPPORT MAINTENANCE
REVERSE OSMOSIS WATER PURIFICATION UNIT FOR
INLAND AND COASTAL LARGE TUG (LT)
ALPHABETICAL INDEX**

<u>Subject</u>	<u>WP Sequence No.-Page No.</u>
20-Micron Filter, Data	0002 00-6
24 Vdc Control Panel Controls and Indicators	0004 00-11
24 Vdc Fuse, Replace	0018 00-4
440V Power Panel No. 5 Circuit Breakers	0004 00-10
5-Micron Filter, Data	0002 00-6
 A 	
Abbreviations	0001 00-2
Acronyms	0001 00-2
Adjust	
High Pressure Cutoff Switch	0024 00-10
Low Pressure Cutoff Switch	0024 00-12
Pressure Regulator Valve	0018 00-2
Valve Misalignment Shutdown Switch	0024 00-14
 B 	
Backflow Preventer Valve, Repair	0018 00-8
Backflush, Media Filter	0005 00-9
Basic Issue Items List	0034 00-12
Battery Charger/Power Supply, Data	0002 00-3
Bll List	0034 00-12
Brine Flow Meter	
Clean	0024 00-10
Replace	0024 00-9
 C 	
Calibrate Salinity Probe	0024 00-6
Change High Pressure Pump Oil	0017 00-1
Charcoal Filter	
Data	0002 00-4
Replace	0027 00-1
Service	0023 00-1
Circuit Breakers, 440V Power Panel No. 5	0004 00-10
Clean	
Brine Flow Meter	0024 00-10
Product Flow Meter	0024 00-9
RO Membranes	0014 00-5
Salinity Probe	0024 00-6
COEI List	0034 00-2
Components of End Item List	0034 00-2
Components of the ROWPU, Theory	0003 00-3
Controls and Indicators	
24 Vdc Control Panel	0004 00-11
Filtration System	0004 00-4
Flow Control Panel	0004 00-5
Media Filter	0004 00-8
ROWPU System	0004 00-1
System Controller	0004 00-6

<u>Subject</u>	<u>WP Sequence No.-Page No.</u>
Corrosion Prevention and Control (CPC)	0001 00-1
CPC	0001 00-1
D	
Description and Use of Operator Controls and Indicators	0004 00-1
Destruction of Army Materiel to Prevent Enemy Use	0001 00-2
Differences Between Models	0002 00-2
E	
Effect, Water Temperature, Theory	0003 00-3
EIR	0001 00-1
Electrical/Piping Lineup	0005 00-1
Electronic Data, Security Measures	0005 00-1
	0006 00-1
Element, Reverse Osmosis Membrane, Data	0002 00-6
Emergency Procedures	0006 00-4
Equipment Characteristics, Capabilities, and Features	0002 00-1
Equipment Data	0002 00-3
Equipment Description and Data	0002 00-1
Expendable and Durable Items List	0035 00-1
F	
Filter Element, Prefiltration Subassembly, Replace	0016 00-1
Filter	
20-Micron, Data	0002 00-6
5-Micron, Data	0002 00-6
Charcoal	
Replace	0027 00-1
Service	0023 00-1
Media	
Repair	0020 00-1
Service	0015 00-1
Filtration System Controls and Indicators	0004 00-4
Fittings, Low Pressure, Replace	0018 00-2
Flow Control Panel	
Controls and Indicators	0004 00-5
Data	0002 00-4
Flush, Fresh Water	0005 00-17
Fresh Water Flush Diverter Valve, Replace	0024 00-16
Fresh Water Flush Pump	
Data	0002 00-3
Replace	0019 00-1
Fuse, 24 Vdc, Replace	0018 00-4
G	
General Information	0001 00-1
Glossary	Glossary-1
High Pressure Cutoff Switch	
Adjust	0024 00-10
Replace	0024 00-11

<u>Subject</u>	<u>WP Sequence No.-Page No.</u>
H	
High Pressure Hoses, Replace	0028 00-1
High Pressure Pump Motor, Lube	0014 00-4
High Pressure Pump	
Change Oil	0017 00-1
Data	0002 00-3
Plunger, Replace	0026 00-1
Repair	0026 00-1
Replace	0021 00-1
Seals, Replace	0026 00-1
Service	0017 00-1
Valves, Replace	0026 00-1
Hose, High Pressure, Replace	0028 00-1
Hose, Low Pressure, Repair	0018 00-1
How to Use This Manual	iii
L	
Layup, ROWPU System	0005 00-19
Lineup, Electrical/Piping	0005 00-1
List of Abbreviations/Acronmys	0001 00-2
Location and Description of Major Components	0002 00-2
Low Pressure Cutoff Switch	
Adjust	0024 00-12
Replace	0024 00-12
Low Pressure Fittings, Replace	0018 00-2
Low Pressure Hose, Repair	0018 00-1
Lube High Pressure Pump Motor	0014 00-4
M	
MAC	0031 00-1
MAC Introduction	0030 00-1
Maintenance Allocation Chart	0031 00-1
Maintenance Allocation Chart Introduction	0030 00-1
Maintenance Forms, Records, and Reports	0001 00-1
Major Components	
Location and Description	0002 00-2
Theory	0003 00-4
Media Filter	
Backflush	0005 00-9
Controls and Indicators	0004 00-8
Data	0002 00-5
Subassembly, Repair	0020 00-1
Substrate, Replace	0015 00-1
Valves	0004 00-9
Service	0015 00-1
Membrane and Vessel Subassembly	
Repair	0022 00-1
Replace	0022 00-3
Replace	0022 00-1

<u>Subject</u>	<u>WP Sequence No.-Page No.</u>
Membrane	
RO, Clean	0014 00-5
Spiral Wound, Theory	0003 00-3
Meter	
Brine Flow	
Clean	0024 00-10
Replace	0024 00-9
Product Flow	
Clean	0024 00-9
Replace	0024 00-7
O	
OBSL	0034 00-7
ODS	0001 00-1
Oil, High Pressure Pump, Change	0017 00-1
On Board Spares List	0034 00-7
Operating Principles, ROWPU, Theory	0003 00-3
Operation Under Unusual Conditions	0006 00-1
Operation Under Usual Conditions	0005 00-1
Operator PMCS	0012 00-1
Operator Troubleshooting Procedures	0008 00-1
Osmosis, Theory	0003 00-1
Ozone Depleting Substances	0001 00-1
P	
Plunger, High Pressure Pump, Replace	0026 00-1
PMCS	
Introduction	0011 00-1
Operator	0012 00-1
Unit	0013 00-1
Power Supply, Data	0002 00-3
Prefiltration Subassembly,	
Filter Element, Replace	0016 00-1
Replace	0025 00-1
Service	0016 00-1
Preliminary Checks and Adjustments of Equipment	0010 00-1
Preliminary Servicing of Equipment	0010 00-1
Preparation for Storage	0010 00-1
Preparation for Storage or Shipment	0001 00-2
Pressure Regulator Valve, Adjust	0018 00-2
Principles of Reverse Osmosis, Theory	0003 00-1
Probe, Salinity	
Calibrate	0024 00-6
Clean	0024 00-6
Replace	0024 00-1
Product Flow Meter	
Clean	0024 00-9
Replace	0024 00-7
Product Water Diverter Valve, Replace	0024 00-17
Pump	
Fresh Water Flush, Replace	0019 00-1
High Pressure	
Motor, Lube	0014 00-4

<u>Subject</u>	<u>WP Sequence No.-Page No.</u>
Pump, High Pressure (continued)	
Plunger, Replace	0026 00-1
Repair	0026 00-1
Replace	0021 00-1
Seals, Replace	0026 00-1
Service	0017 00-1
Valves, Replace	0026 00-1
Q	
Quality of Material	0001 00-3
R	
References	0029 00-1
Repair	
Backflow Preventer Valve	0018 00-8
High Pressure Pump	0026 00-1
Low Pressure Hose	0018 00-1
Media Filter Subassembly	0020 00-1
Parts and Special Tools List	0033 00-1
Parts and Special Tools List Introduction	0032 00-1
ROWPU	0018 00-1
	0028 00-1
ROWPU Unit	0024 00-1
Sil Braze Valve	0020 00-1
Replace	
24 Vdc Fuse	0018 00-4
Brine Flow Meter	0024 00-9
Charcoal Filter	0027 00-1
Fresh Water Flush Diverter Valve	0024 00-16
Replace (continued)	
Fresh Water Flush Pump	0019 00-1
High Pressure Cutoff Switch	0024 00-11
High Pressure Hoses	0028 00-1
High Pressure Pump	0021 00-1
High Pressure Pump Plunger	0026 00-1
High Pressure Pump Seals	0026 00-1
High Pressure Pump Valves	0026 00-1
Low Pressure Cutoff Switch	0024 00-13
Low Pressure Fittings	0018 00-2
Media Filter Substrate	0015 00-1
Prefiltration Subassembly	0025 00-1
Prefiltration Subassembly Filter Element	0016 00-1
Product Flow Meter	0024 00-7
Product Water Diverter Valve	0024 00-17
Salinity Probe	0024 00-1
Valve Misalignment Shutdown Switch	0024 00-15
Reporting Equipment Improvement Recommendations (EIR)	0001 00-1
Reverse Osmosis Membrane Element, Data	0002 00-6
Reverse Osmosis, Theory	0003 00-1
ROWPU	
Components, Theory	0003 00-3
Fresh Water Flush	0005 00-17
Operating Principles, Theory	0003 00-3

<u>Subject</u>	<u>WP Sequence No.-Page No.</u>
ROWPU (continued)	
Repair	0018 00-1
	0028 00-1
Service	0014 00-1
System 24 Vdc Battery Charger/Power Supply, Data	0002 00-3
System Controls and Indicators	0004 00-1
System Layup	0005 00-19
Unit, Repair	0024 00-1
RPSTL	0033 00-1
RPSTL Introduction	0032 00-1
S	
Salinity Probe	
Calibrate	0024 00-6
Clean	0024 00-6
Replace	0024 00-1
Salinity, Unusual Conditions	0006 00-1
Scope	0001 00-1
Seals, High Pressure Pump, Replace	0026 00-1
Security Measures for Electronic Data	0005 00-1
	0006 00-1
Service	
Charcoal Filter	0023 00-1
Fresh Water Flush Pump Inlet Strainer	0014 00-1
High Pressure Pump	0017 00-1
Media Filter	0015 00-1
Prefiltration Subassembly	0016 00-1
ROWPU	0014 00-1
Upon Receipt	0010 00-1
Shelter Requirements	0010 00-1
Shutdown	
ROWPU 1	0005 00-16
ROWPU 2	0005 00-16
ROWPU System	0005 00-17
Sil Braze Valve, Repair	0020 00-1
Spiral Wound Membrane, Theory	0003 00-3
Startup	0005 00-1
ROWPU 1	0005 00-11
ROWPU 2	0005 00-14
Strainer, Fresh Water Flush Pump Inlet, Service	0014 00-1
Substrate, Media Filter, Replace	0015 00-1
Switch	
High Pressure Cutoff	
Adjust	0024 00-10
Replace	0024 00-11
Low Pressure Cutoff	
Adjust	0024 00-12
Replace	0024 00-12
Valve Misalignment Shutdown	
Adjust	0024 00-14
Replace	0024 00-15
System Controller	
Controls and Indicators	0004 00-6
Data	0002 00-5

<u>Subject</u>	<u>WP Sequence No.-Page No.</u>
System Operating Pressure, Unusual Conditions	0006 00-1
T	
Table of Contents	i
Temperature, Unusual Conditions	0006 00-1
Theory of Operation	0003 00-1
Troubleshooting	
Index	0007 00-1
Procedures	
Operator	0008 00-1
Unit	0009 00-1
Use of	0007 00-1
U	
Unit PMCS	0013 00-1
Unit Troubleshooting Procedures	0009 00-1
Unusual Environment/Weather, Unusual Conditions	0006 00-1
Use of Troubleshooting Procedures	0007 00-1
V	
Valve Misalignment Shutdown Switch	
Adjust	0024 00-14
Replace	0024 00-15
Valve	
Backflow Preventer, Repair	0018 00-8
Fresh Water Flush Diverter, Replace	0024 00-16
Pressure Regulator, Adjust	0018 00-2
Product Water Diverter, Replace	0024 00-17
Sil Braze, Repair	0020 00-1
Valves	
High Pressure Pump, Replace	0026 00-1
Media Filter	0004 00-9
W	
Warning Summary	a
Warranty Information	0001 00-2
Water Temperature Effect, Theory	0003 00-3

By Order of the Secretary of the Army:

Official:

SANDRA R. RILEY
*Administrative Assistant to the
Secretary of the Army*

0529215

PETER J. SCHOOMAKER
*General, United States Army
Chief of Staff*

DISTRIBUTION: To be distributed in accordance with the initial distribution requirements for IDN: 255632, requirements for TM 55-1925-282-14&P.

RECOMMENDED CHANGES TO PUBLICATIONS AND BLANK FORMS For use of this form, see AR 25-30; the proponent agency is OAASA	Use Part II (<i>reverse</i>) for Repair Parts and Special Tool Lists (RPSTL) and Supply Catalogs/Supply Manuals (SC/SM).	DATE
---	--	------

TO: (<i>Forward to proponent of publication or form</i>) (<i>Include ZIP Code</i>) AMSTA-LC-LMPP / TECH PUBS 1 Rock Island Arsenal Rock Island, IL 61299-7630	FROM: (<i>Activity and location</i>) (<i>Include ZIP Code</i>)
---	---

PART I - ALL PUBLICATIONS (EXCEPT RPSTL AND SC/SM) AND BLANK FORMS

PUBLICATION/FORM NUMBER TM 55-1925-282-14&P	DATE 30 November 2005	TITLE Operator, Unit, Direct Support, and General Support Maintenance Manual In- cluding Repair Parts and Special Tools List for Reverse Osmosis Water Purification Unit (ROWPU) Inland and Coastal Large Tug (LT) NSN 1925-01-509-7013 (EIC XAG)
--	--------------------------	---

ITEM	PAGE	PARA- GRAPH	LINE	FIGURE NO.	TABLE	RECOMMENDED CHANGES AND REASON
<h1>SAMPLE</h1>						

** Reference to line numbers within the paragraph or subparagraph.*

TYPED NAME, GRADE OR TITLE <p style="text-align: center;">Your name</p>	TELEPHONE EXCHANGE/AUTOVON, PLUS EXTENSION	SIGNATURE <p style="text-align: center;">Your Signature</p>
--	---	--

TO: <i>(Forward direct to addressee listed in publication)</i> AMSTA-LC-LMPP / TECH PUBS 1 Rock Island Arsenal Rock Island, IL 61299-7630	FROM: <i>(Activity and location) (Include ZIP Code)</i>	DATE
---	--	-------------

PART II - REPAIR PARTS AND SPECIAL TOOL LISTS AND SUPPLY CATALOGS/SUPPLY MANUALS

PUBLICATION NUMBER TM 55-1925-282-14&P	DATE 30 November 2005	TITLE Operator, Unit, Direct Support, and General Support Maintenance Manual Including Repair Parts and Special Tools List for Reverse Osmosis Water Purification Unit (ROWPU) Inland and Coastal Large Tug (LT) NSN 1925-01-509-7013 (EIC XAG)
--	---------------------------------	--

PAGE NO.	COLM NO.	LINE NO.	NATIONAL STOCK NUMBER	REFERENCE NO.	FIGURE NO.	ITEM NO.	TOTAL NO. OF MAJOR ITEMS SUPPORTED	RECOMMENDED ACTION
SAMPLE								

PART III - REMARKS *(Any general remarks or recommendations, or suggestions for improvement of publications and blank forms. Additional blank sheets may be used if more space is needed.)*

TYPED NAME, GRADE OR TITLE	TELEPHONE EXCHANGE/AUTOVON, PLUS EXTENSION	SIGNATURE
-----------------------------------	---	------------------

RECOMMENDED CHANGES TO PUBLICATIONS AND BLANK FORMS For use of this form, see AR 25-30; the proponent agency is OAASA	Use Part II (<i>reverse</i>) for Repair Parts and Special Tool Lists (RPSTL) and Supply Catalogs/Supply Manuals (SC/SM).	DATE
---	--	------

TO: (<i>Forward to proponent of publication or form</i>) (<i>Include ZIP Code</i>) AMSTA-LC-LMPP / TECH PUBS 1 Rock Island Arsenal Rock Island, IL 61299-7630	FROM: (<i>Activity and location</i>) (<i>Include ZIP Code</i>)
---	---

PART I - ALL PUBLICATIONS (EXCEPT RPSTL AND SC/SM) AND BLANK FORMS

PUBLICATION/FORM NUMBER TM 55-1925-282-14&P	DATE 30 November 2005	TITLE Operator, Unit, Direct Support, and General Support Maintenance Manual In- cluding Repair Parts and Special Tools List for Reverse Osmosis Water Purification Unit (ROWPU) Inland and Coastal Large Tug (LT) NSN 1925-01-509-7013 (EIC XAG)
--	--------------------------	---

ITEM	PAGE	PARA- GRAPH	LINE	FIGURE NO.	TABLE	RECOMMENDED CHANGES AND REASON

** Reference to line numbers within the paragraph or subparagraph.*

TYPED NAME, GRADE OR TITLE	TELEPHONE EXCHANGE/AUTOVON, PLUS EXTENSION	SIGNATURE

TO: <i>(Forward direct to addressee listed in publication)</i> AMSTA-LC-LMPP / TECH PUBS 1 Rock Island Arsenal Rock Island, IL 61299-7630	FROM: <i>(Activity and location) (Include ZIP Code)</i>	DATE
---	--	-------------

PART II - REPAIR PARTS AND SPECIAL TOOL LISTS AND SUPPLY CATALOGS/SUPPLY MANUALS

PUBLICATION NUMBER TM 55-1925-282-14&P	DATE 30 November 2005	TITLE Operator, Unit, Direct Support, and General Support Maintenance Manual Including Repair Parts and Special Tools List for Reverse Osmosis Water Purification Unit (ROWPU) Inland and Coastal Large Tug (LT) NSN 1925-01-509-7013 (EIC XAG)
--	---------------------------------	--

PAGE NO.	COLM NO.	LINE NO.	NATIONAL STOCK NUMBER	REFERENCE NO.	FIGURE NO.	ITEM NO.	TOTAL NO. OF MAJOR ITEMS SUPPORTED	RECOMMENDED ACTION

PART III - REMARKS *(Any general remarks or recommendations, or suggestions for improvement of publications and blank forms. Additional blank sheets may be used if more space is needed.)*

TYPED NAME, GRADE OR TITLE	TELEPHONE EXCHANGE/AUTOVON, PLUS EXTENSION	SIGNATURE

RECOMMENDED CHANGES TO PUBLICATIONS AND BLANK FORMS For use of this form, see AR 25-30; the proponent agency is OAASA	Use Part II (<i>reverse</i>) for Repair Parts and Special Tool Lists (RPSTL) and Supply Catalogs/Supply Manuals (SC/SM).	DATE
---	--	------

TO: (<i>Forward to proponent of publication or form</i>) (<i>Include ZIP Code</i>) AMSTA-LC-LMPP / TECH PUBS 1 Rock Island Arsenal Rock Island, IL 61299-7630	FROM: (<i>Activity and location</i>) (<i>Include ZIP Code</i>)
---	---

PART I - ALL PUBLICATIONS (EXCEPT RPSTL AND SC/SM) AND BLANK FORMS

PUBLICATION/FORM NUMBER TM 55-1925-282-14&P	DATE 30 November 2005	TITLE Operator, Unit, Direct Support, and General Support Maintenance Manual In- cluding Repair Parts and Special Tools List for Reverse Osmosis Water Purification Unit (ROWPU) Inland and Coastal Large Tug (LT) NSN 1925-01-509-7013 (EIC XAG)
--	--------------------------	---

ITEM	PAGE	PARA- GRAPH	LINE	FIGURE NO.	TABLE	RECOMMENDED CHANGES AND REASON
------	------	----------------	------	---------------	-------	--------------------------------

--	--	--	--	--	--	--

** Reference to line numbers within the paragraph or subparagraph.*

TYPED NAME, GRADE OR TITLE	TELEPHONE EXCHANGE/AUTOVON, PLUS EXTENSION	SIGNATURE
----------------------------	---	-----------

TO: <i>(Forward direct to addressee listed in publication)</i> AMSTA-LC-LMPP / TECH PUBS 1 Rock Island Arsenal Rock Island, IL 61299-7630	FROM: <i>(Activity and location) (Include ZIP Code)</i>	DATE
---	--	-------------

PART II - REPAIR PARTS AND SPECIAL TOOL LISTS AND SUPPLY CATALOGS/SUPPLY MANUALS

PUBLICATION NUMBER TM 55-1925-282-14&P	DATE 30 November 2005	TITLE Operator, Unit, Direct Support, and General Support Maintenance Manual Including Repair Parts and Special Tools List for Reverse Osmosis Water Purification Unit (ROWPU) Inland and Coastal Large Tug (LT) NSN 1925-01-509-7013 <small>(EIC XAG)</small>
--	---------------------------------	--

PAGE NO.	COLM NO.	LINE NO.	NATIONAL STOCK NUMBER	REFERENCE NO.	FIGURE NO.	ITEM NO.	TOTAL NO. OF MAJOR ITEMS SUPPORTED	RECOMMENDED ACTION

PART III - REMARKS *(Any general remarks or recommendations, or suggestions for improvement of publications and blank forms. Additional blank sheets may be used if more space is needed.)*

TYPED NAME, GRADE OR TITLE	TELEPHONE EXCHANGE/AUTOVON, PLUS EXTENSION	SIGNATURE
-----------------------------------	---	------------------

RECOMMENDED CHANGES TO PUBLICATIONS AND BLANK FORMS <small>For use of this form, see AR 25-30; the proponent agency is OAASA</small>	Use Part II (<i>reverse</i>) for Repair Parts and Special Tool Lists (RPSTL) and Supply Catalogs/Supply Manuals (SC/SM).	DATE

TO: (<i>Forward to proponent of publication or form</i>) (<i>Include ZIP Code</i>) AMSTA-LC-LMPP / TECH PUBS 1 Rock Island Arsenal Rock Island, IL 61299-7630	FROM: (<i>Activity and location</i>) (<i>Include ZIP Code</i>)
---	---

PART I - ALL PUBLICATIONS (EXCEPT RPSTL AND SC/SM) AND BLANK FORMS

PUBLICATION/FORM NUMBER TM 55-1925-282-14&P	DATE 30 November 2005	TITLE Operator, Unit, Direct Support, and General Support Maintenance Manual Including Repair Parts and Special Tools List for Reverse Osmosis Water Purification Unit (ROWPU) Inland and Coastal Large Tug (LT) NSN 1925-01-509-7013 (EIC XAG)
--	--------------------------	---

ITEM	PAGE	PARA-GRAPH	LINE	FIGURE NO.	TABLE	RECOMMENDED CHANGES AND REASON

** Reference to line numbers within the paragraph or subparagraph.*

TYPED NAME, GRADE OR TITLE	TELEPHONE EXCHANGE/AUTOVON, PLUS EXTENSION	SIGNATURE

TO: <i>(Forward direct to addressee listed in publication)</i> AMSTA-LC-LMPP / TECH PUBS 1 Rock Island Arsenal Rock Island, IL 61299-7630	FROM: <i>(Activity and location) (Include ZIP Code)</i>	DATE
---	--	-------------

PART II - REPAIR PARTS AND SPECIAL TOOL LISTS AND SUPPLY CATALOGS/SUPPLY MANUALS

PUBLICATION NUMBER TM 55-1925-282-14&P	DATE 30 November 2005	TITLE Operator, Unit, Direct Support, and General Support Maintenance Manual Including Repair Parts and Special Tools List for Reverse Osmosis Water Purification Unit (ROWPU) Inland and Coastal Large Tug (LT) NSN 1925-01-509-7013 (EIC XAG)
--	---------------------------------	--

PAGE NO.	COLM NO.	LINE NO.	NATIONAL STOCK NUMBER	REFERENCE NO.	FIGURE NO.	ITEM NO.	TOTAL NO. OF MAJOR ITEMS SUPPORTED	RECOMMENDED ACTION

PART III - REMARKS *(Any general remarks or recommendations, or suggestions for improvement of publications and blank forms. Additional blank sheets may be used if more space is needed.)*

TYPED NAME, GRADE OR TITLE	TELEPHONE EXCHANGE/AUTOVON, PLUS EXTENSION	SIGNATURE

Metric Conversion Factors

Mc x F = Cf		
Measurement to be Converted (Mc)	Factor (F)	Converted Measurement (Cf)
Meters (m)	x 39.37	= Inches (in.)
Meters (m)	x 3.281	= Feet (ft)
Meters (m)	x 1.094	= Yards (yd)
Inches (in.)	x 25.40	= Millimeters (mm)
Inches (in.)	x 2.54	= Centimeters (cm)
Inches (in.)	x 0.0254	= Meters (m)
Inches (in.)	x 25400	= Micrometers (μm)
Feet (ft)	x 0.305	= Meters (m)
Square feet (ft ²)	x 0.093	= Square meters (m ²)
Foot-Pounds	x 1.35582	= Newton meters (N m)
Newton meters (N m)	x 0.73756	= Foot Pounds
Yards (yd)	x 0.914	= Meters (m)
Square yards (yd ²)	x 0.836	= Square meters (m ²)
Square Inches (in ²)	x 6.452	= Square Centimeters (cm ²)
Cubic Inches (in ³)	x 16.39	= Cubic Centimeters (cm ³)
Cubic Centimeters (cm ³)	x 0.061	= Cubic Inches (in ³)
Cubic Feet (ft ³)	x 0.028	= Cubic Meters (cm ³)
Gallons (gal)	x 3.785	= Liters (L)
Liters (L)	x 0.2642	= Gallons (gal)
Kilometers (km)	x 0.5397	= Nautical miles (nmi)
Meters (m)	x 0.0005397	= Nautical miles (nmi)
Nautical miles (nmi)	x 1.853	= Kilometers (km)
Fluid Ounces (oz)	x 29.574	= Milliliters (mL)
Pounds (lb)	x 0.4536	= Kilograms (kg)
Kilograms (kg)	x 2.2046	= Pounds (lb)
Kilopascals (kPa)	x 0.145	= Pounds (lb) per Square Inch (psi)
Pounds per Square Inch (psi)	x 6.895	= Kilopascals (kPa)
Degrees Centigrade (°C)	(°C x 1.8) + 32	= Degrees Fahrenheit (°F)
Degrees Fahrenheit (°F)	(°F-32) ÷ 1.8	= Degrees Centigrade (°C)
Bar	x 14.5	= Pounds per Square Inch (psi)
Pounds per Square Inch (psi)	x 0.06894	= Bar
Horsepower (hp)	x 0.746	= Kilowatt (kW)
Kilowatt (kW)	x 1.341	= Horsepower (hp)

